

TECHNICAL MEMORANDUM

Contract No.: T4541-AO
Report No.: 405160-12
Project Name: Steel Posts Over Underground Structures
Sponsor: Pooled Fund

DATE: January 29, 2009

TO: David Olson
Chair, Pooled Fund

COPY TO: Will Longstreet, PennDOT
Rhonda Brooks, Washington State DOT
Jesus Palomo, TTI RDO
D. L. Bullard, Jr., Head, TTI Safety & Structural Systems
Roger P. Bligh, TTI Roadway Safety Program
Rebecca Haug, TTI Safety & Structural Systems

FROM: 
William F. Williams, P.E., Asst. Res. Engineer, Texas Transportation Institute
WLM Wanda L. Menges, Research Specialist, Texas Transportation Institute

FOR MORE INFORMATION:

Name: William F. Williams
Phone: 979-862-2297
Email: w-williams@ttimail.tamu.edu

SUMMARY REPORT:

INTRODUCTION

For guardrail installations across low-fill culverts, small structures, or underground obstructions where proper post embedment cannot be achieved, either long span guardrail or steel post over underground structures similar to the details shown in figure 1 are desirable.

The details shown in figure 1 would allow for the guardrail post to be anchored to a shallow foundation that is constructed on top of the obstruction. However, physical crash testing of the details shown in this figure according to National Cooperative Highway Research Program (NCHRP) *Report 350* Test Level 3 requirements has not been performed. Moment slabs can become an expensive alternative to most local municipalities that might use a detail such as the one shown in figure 1. Therefore, there is a need for a more cost-effective design for this situation.

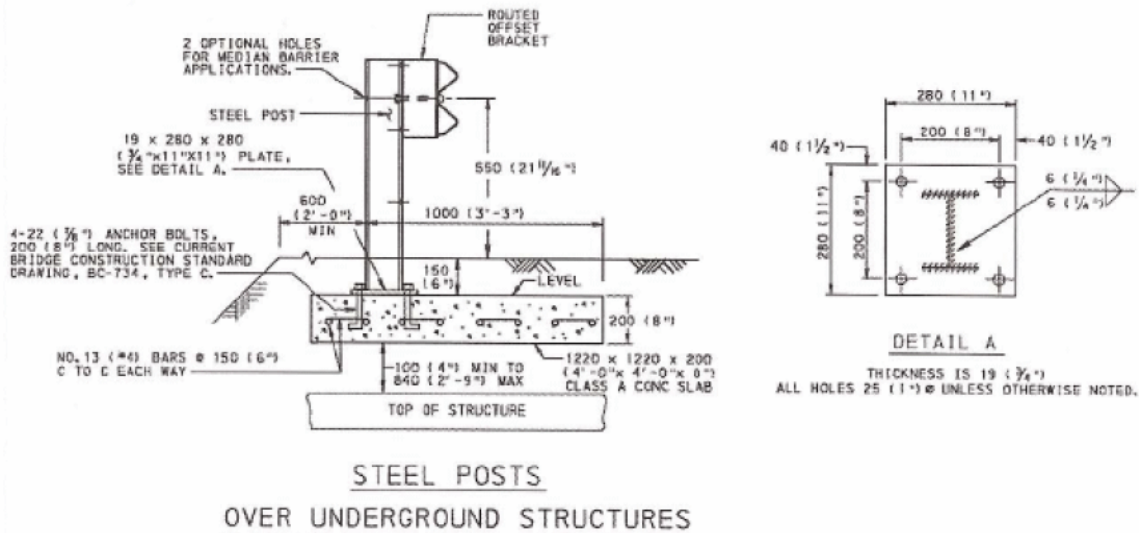

Figure 1. Steel Post Over Underground Structures.

BACKGROUND

As part of this pooled fund program, a w-beam guardrail system using W6x9 steel guardrail post was anchored to a simulated concrete box culvert and crash tested (see TTI Project Box Culvert Guard Rail TTI Project No. 405160-5). The height of the fill used on top of the box culvert was 9.0 inches. The crash test was performed in accordance with *NCHRP Report 350* TL-3 Specifications (Test No. 3-11). The results of the crash test were successful with respect to *NCHRP Report 350* requirements for Test Level 3. For this project, design and crash test information obtained from the steel post anchored to the box culvert project was used. Information from this study as well as engineering design and pendulum testing of a W6x9 steel guardrail post anchored to a shallow moment slab were used to develop a design for a steel post supported by a shallow moment slab for use over underground structures.

OBJECTIVE

The objective of this study is to develop a steel post design anchored to a shallow moment slab for use on a typical strong post w-beam guardrail system. This shallow moment slab would be utilized whenever underground obstruction(s) are encountered preventing the use of a full depth guardrail post (typically 44 inches below grade). This post with shallow foundation design would serve as a viable alternative for supporting a guardrail post where shallow underground obstruction(s) exist.

RESEARCH METHODOLOGY

Engineering analyses were performed on several design options. These options were submitted to the state technical representative for review and approval. The state technical representative sent these options to the supporting state members in the pooled fund for review and approval.

Several design options were analyzed. One option utilizing a 5 ft x 5 ft square footing was recommended for full scale pendulum testing. Details of this design are presented in figures 2 and 3. Based on the performance of this design, a 4 ft x 4 ft square footing was also a testing option.

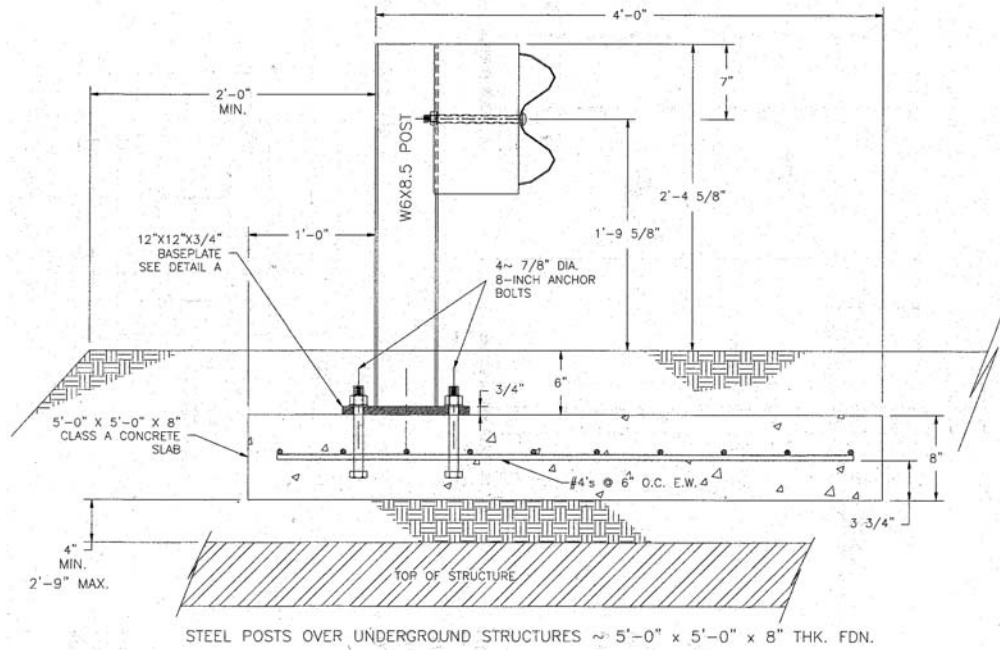

Figure 2. 5 ft x 5 ft Footing Cross-Section.

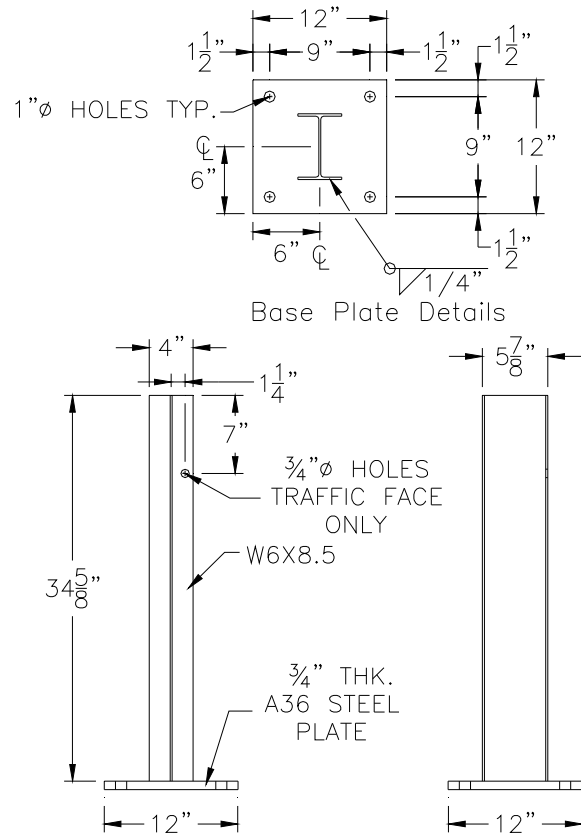

Figure 3. Steel Post Details.

For this project, two pendulum tests were performed on the steel posts mounted on two different moment slabs. The objective of the pendulum tests described herein is to document the impact performance of the steel posts over underground structures and assess the potential for meeting the recommended safety performance guidelines set forth in *NCHRP Report 350*.

Pendulum testing was performed the morning of September 17, 2008. Weather conditions at the time of testing were as follows: Wind speed: 4-5 mi/h; wind direction: 57 degrees with respect to the pendulum bogie; temperature: 63-70 °F; relative humidity: 66-86 percent.

PENDULUM FACILITY

The test articles for this project were tested at Texas Transportation Institute (TTI) Proving Ground outdoor pendulum testing facility. The pendulum bogie, built according to the specifications of the Federal Outdoor Impact Laboratory's (FOIL) pendulum, and the testing area are shown in the adjacent figure. Frontal crush of the aluminum honeycomb nose of the bogie simulates the crush of an actual vehicle and the sweeper plate, constructed of steel angles and a steel plate, is attached to the body of the pendulum with a ground clearance of 6 inches to replicate roughly an automobile's undercarriage. The crushable nose configuration is the FOIL ten stage bogie nose. Cartridges of expendable aluminum honeycomb material of differing densities are placed in a sliding nose. For this project, the pendulum impacted the two steel posts mounted to the shallow concrete footings at a target speed of 22 mph and at a height of 20.5 inches above the ground. This height closely represents the bumper height of a small passenger car. After a test, the honeycomb material is replaced and the bogie is reused. A sketch of the honeycomb configuration used for the pendulum bogie is shown in Appendix A. Testing was performed in accordance with *NCHRP Report 350* and a brief description of the procedures is presented in Appendix B.



TEST ARTICLE DESIGN AND CONSTRUCTION

TTI received preliminary details for the steel post anchored to a shallow concrete footing from William Longstreet with Pennsylvania Department of Transportation (PennDOT). For this project, two W6x8.5 guardrail posts were anchored to two simulated concrete footings of different sizes. One footing measured 4 ft x 4 ft in plan and the second footing measured 5 ft x 5 ft in plan. Both footings were 8 inches thick. The steel post anchored to the 5 ft x 5 ft concrete footing was tested first. Both footings were reinforced with a single layer of reinforcing steel spaced on 6 inch centers in both the transverse and longitudinal directions. A 6 inch layer of compacted soil was placed on top of the footings. The W6x8.5 posts were welded to 12 inch x 12 inch x 3/4-inch thick base plates and anchored to the 8-inch thick concrete footings with four 7/8-inch diameter, A325 bolts cast within the footings. These anchor bolts were 8 inches in length and were embedded a minimum of 6 inches into the footings. Concrete compressive strengths tests performed the day the testing was performed on samples of the footing concrete

yielded an average compressive strength of 3669 psi. Additional details are shown in Appendix C.

TEST P1 ON 5 ft x 5 ft CONCRETE FOOTING

The pendulum bogie, traveling at an impact speed of 21.6 mi/h (34.7 km/h), impacted the guardrail post with the centerline of the pendulum nose aligned with the centerline of the steel post. The center height of the nose was 20.5 inches above finished grade. At 0.005 s, the steel post began to deform, and at 0.046 s, the concrete footing began to lift up in the soil. The pendulum bogie lost contact with the steel post at 0.155 s, and exit speed at loss of contact was 8.5 mi/h. At 0.260 s, the concrete footing began to rotate, and at 0.352 s, the base of the pendulum contacted the post. The pendulum bogie came to rest on top the steel post at 0.994 s. Maximum dynamic deflection of the steel post during the test was 20.0 inches, and the final deformation of the steel post was approximately 12.25 inches. The footing was moved as a result of the pendulum impact on the post. The leading edge of the footing (traffic face edge) was uplifted and came to rest approximately 3.0 inches above the grade surface. After the test, no visible distress was observed in the concrete footing, post baseplate, or anchor bolts.

Maximum rise of the nose of the pendulum during the test was 24.1 inches, and maximum crush of the honeycomb nose of the pendulum was 10.1 inches. Photographs of the installation before and after the test, are shown in Appendix D, figures D1 through D2.

Longitudinal occupant impact velocity was 24.6 ft/s (7.5 m/s), longitudinal ridedown acceleration was $-3.6 g$'s, and maximum 50-ms average was $-8.7 g$'s. Change in velocity at loss of contact was 19.2 ft/s (5.9 m/s). The data and other pertinent information are presented in Appendix D, table D1. Acceleration and force graphs are shown in Appendix E, figure E1 and E2.

TEST P2 ON 4 ft x 4ft CONCRETE FOOTING

The pendulum bogie, traveling at an impact speed of 21.5 mi/h (34.6 km/h), impacted the guardrail post with the centerline of the pendulum nose aligned with the centerline of the steel post. The height of the nose was measured at 20.5 inches. At 0.020 s, the steel post began to deform, and at 0.032 s, the concrete footing began to lift up in the soil. The pendulum bogie lost contact with the steel post at 0.144 s, and exit speed at loss of contact was 7.8 mi/h. The base of the pendulum contacted the steel post at 0.332 s, and then loses contact with the steel post at 0.398 s. At 0.537 s, the base contacted the steel post again, and at 0.562 s, the pendulum went over the steel post.

Maximum deflection of the steel post during the test was 29.1 inches, and the final deformation of the post was approximately 6.5 inches. The footing was moved as a result of the pendulum impact on the post. The leading edge of the footing (traffic face edge) was uplifted and came to rest approximately 6.0 inches above the grade surface. After the test, no visible distress was observed in the concrete footing, post baseplate, or anchor bolts. Maximum rise of the nose of the pendulum during the test was 23.6 inches, and maximum crush of the honeycomb nose of the pendulum was 10.7 inches. Photographs of the installation before and after the test are shown in Appendix D, figures D3 through D4.

Longitudinal occupant impact velocity was 20.7 ft/s (6.3 m/s), longitudinal ridedown acceleration was $-2.9 g$'s, and maximum 50-ms average was $-8.5 g$'s. Change in velocity at loss of contact was 20.1 ft/s (6.1 m/s). These data and other pertinent information are presented in

Appendix D, table D2. Acceleration and force graphs are shown in Appendix E, figure E3 and E4.

SUMMARY AND CONCLUSIONS

Full-scale pendulum tests were performed on the two footing designs. The posts were loaded in bending about the strong axis. The 5 ft x 5 ft footing rotated approximately 6 degrees and the dynamic rotation of the post was approximately 30 degrees. The 4 ft x 4 ft footing rotated approximately 15 degrees from the pendulum impact. The dynamic rotation of the post for the 4 ft x 4 ft footing was in excess of 30 degrees. Plastic failure occurred in the W6x8.5 steel posts for both designs tested. No distress was observed in the anchor bolts or concrete for both tests.

A comparison was made between the posts and concrete foundations tested for this project and standard W-beam guardrail line posts embedded in strong soil. Two pendulum tests were performed on W6x8.5 steel posts embedded in *NCHRP Report 350* strong soil and embedded approximately 43.4 inches (TTI Project 220547). For both tests, the center height of the pendulum was 18.0 inches above grade. Figure 4 shows the force versus displacement for the W6x8.5 post anchor to the 5 ft by 5 ft concrete foundation along with the force versus displacement curves obtained for the W6x8.5 steel post embedded in strong soil for Project 220547. Figure 5 shows the force versus displacement for the W6x8.5 steel post anchored to the 4 ft by 4 ft concrete foundations. The force versus displacement for the same W6x8.5 line posts used in Figure 5 are also shown. The force versus displacement curves for both posts tested for this project compared very closely to the force versus displacement curves for the W6x8.5 steel posts embedded 43.4 inches in strong soil.

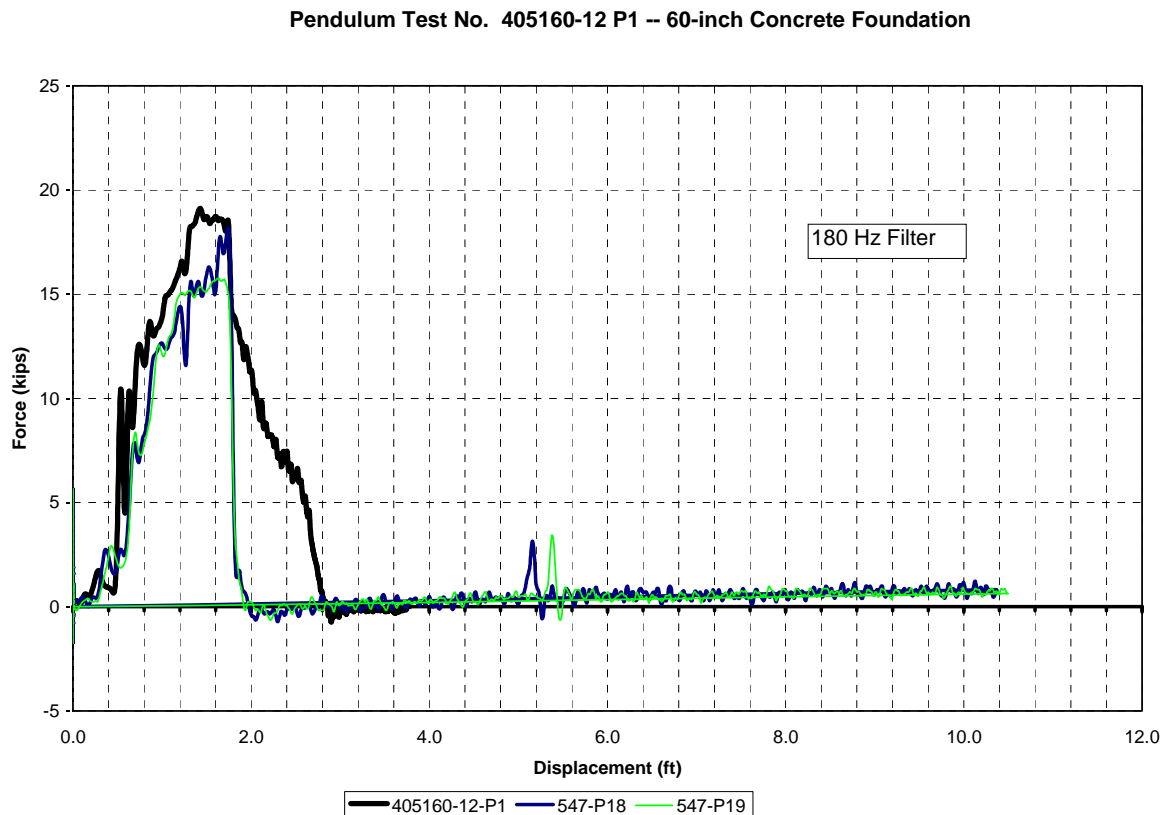

Figure 4. Force versus displacement comparison for post on 5 ft x 5 ft slab and posts in strong soil.

Pendulum Test No. 405160-12 P2 -- 48-inch Concrete Foundation

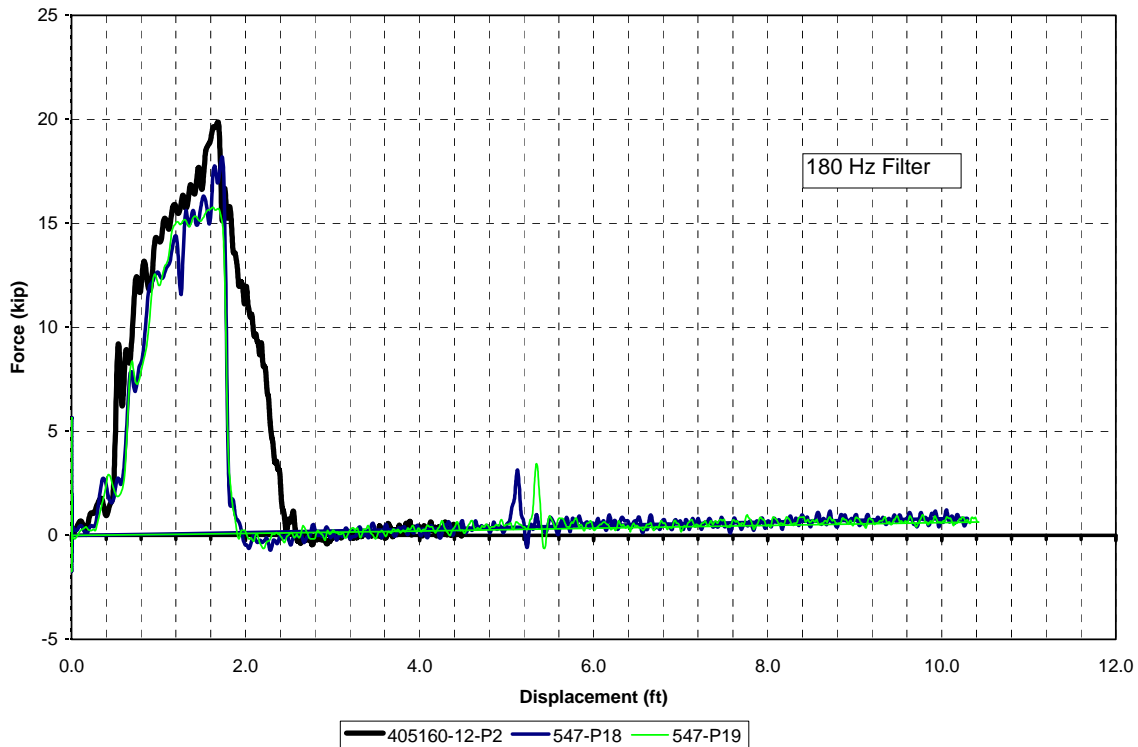
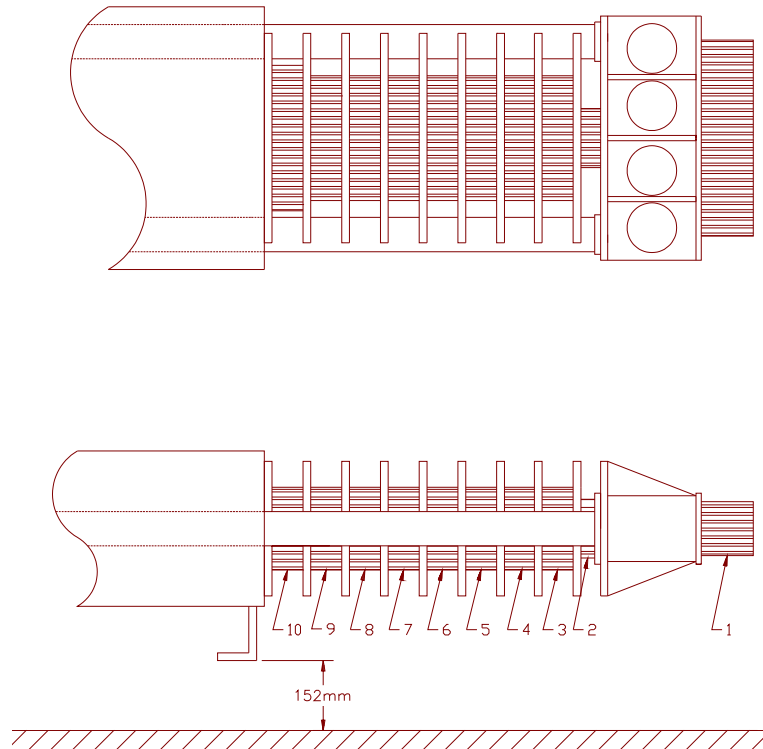

Figure 5. Force versus displacement comparison for post on 4 ft x4 ft slab and posts in strong soil.

The posts anchored to the footings exhibited greater strength than those tested in strong soil over 0 to 2 ft of displacement. The dynamic rotation of the 5 ft x 5 ft footing was approximately 30 degrees and greater than 30 degrees for the 4 ft x 4 ft footing tested for this project. The dynamic rotation of the 4 ft x 4 ft footing and post was deemed undesirable since the footing came to rest approximately 6 inches above grade surface. Based on the results of this testing, the W6x8.5 steel post anchored to the 5 ft by 5 ft concrete footing is recommended for use in cases where a single post in a guardrail length of need interferes with an underground obstruction. A full-scale crash test should be performed to validate the performance where multiple posts in succession anchored to shallow 5 ft by 5 ft concrete footing as tested herein is required.

ATTACHMENT A: TEST ARTICLE DETAILS



| Cartridge Number | Size (mm) | Area Effectively Removed by Pre-Crushing (mm ²) | Static Crush Strength (kPa) | Total Crush Force for Each Cartridge (kN) |
|------------------|-----------------|---|-----------------------------|---|
| 1 | 69.9 × 406 × 76 | | 896.3 | 25.4 |
| 2 | 102 × 127 × 51 | | 172.4 | 2.2 |
| 3 | 203 × 203 × 76 | 13549 | 896.3 | 24.8 |
| 4 | 203 × 203 × 76 | 9678 | 1585.8 | 50.0 |
| 5 | 203 × 203 × 76 | 3871 | 1585.8 | 59.2 |
| 6 | 203 × 203 × 76 | | 1585.8 | 65.3 |
| 7 | 203 × 203 × 76 | 13549 | 2757.9 | 76.3 |
| 8 | 203 × 203 × 76 | 7742 | 2757.9 | 92.3 |
| 9 | 203 × 203 × 76 | | 2757.9 | 113.6 |
| 10 | 203 × 254 × 76 | | 2757.9 | 142.3 |

Configuration of pendulum nose and honeycomb.

ATTACHMENT B. PENDULUM TEST PROCEDURES AND DATA ANALYSIS

The pendulum test and data analysis procedures were in accordance with guidelines presented in *NCHRP Report 350*. Brief descriptions of these procedures are presented as follows.

ELECTRONIC INSTRUMENTATION AND DATA PROCESSING

The bogie was instrumented with two accelerometers mounted at the rear of the bogie to measure longitudinal acceleration levels. The accelerometers were strain gage type with a linear millivolt output proportional to acceleration.

The electronic signals from the accelerometers were amplified and transmitted to a base station by means of constant bandwidth FM/FM telemetry link for recording on magnetic tape and for display on a real-time strip chart. Calibration signals were recorded before and after the test and an accurate time reference signal was simultaneously recorded with the data. Pressure sensitive switches on the nose of the bogie were actuated by wooden dowel rods and initial contact to produce speed trap and "event" marks on the data record to establish the exact instant of contact with the installation, as well as impact velocity.

The multiplex of data channels, transmitted on one radio frequency, is received and demultiplexed onto TEAC[®] instrumentation data recorder. After the test, the data are played back from the TEAC[®] recorder and digitized. A proprietary software program (WinDigit) converts the analog data from each transducer into engineering units using the R-cal and pre-zero values at 10,000 samples per second, per channel. WinDigit also provides Society of Automotive Engineers (SAE) J211 class 180 phaseless digital filtering and bogie impact velocity.

The Test Risk Assessment Program (TRAP) uses the data from WinDigit to compute occupant/compartiment impact velocities, time of occupant/compartiment impact after bogie impact, and the highest 10-ms average ridedown acceleration. WinDigit calculates change in bogie velocity at the end of a given impulse period. In addition, maximum average accelerations over 50-ms are computed. For reporting purposes, the data from the bogie-mounted accelerometers were then filtered with a 180 Hz digital filter and plotted using a commercially available software package (Microsoft EXCEL).

PHOTOGRAPHIC INSTRUMENTATION

A high-speed digital camera, positioned perpendicular to the path of the pendulum bogie and the test article, was used to record the collision period. The film from this high-speed camera was analyzed on a computer to observe phenomena occurring during the collision and to obtain time-event, displacement, and angular data. A mini-DV camera and still cameras were used to document the crushable pendulum nose and the test article before and after the test.

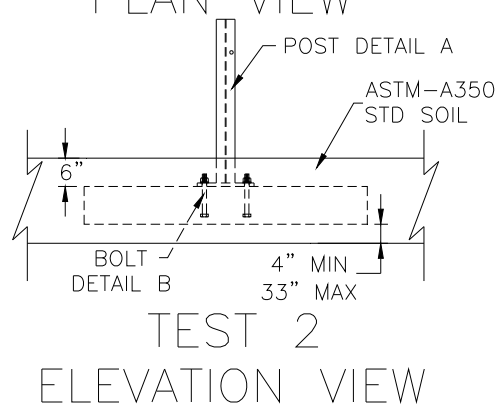
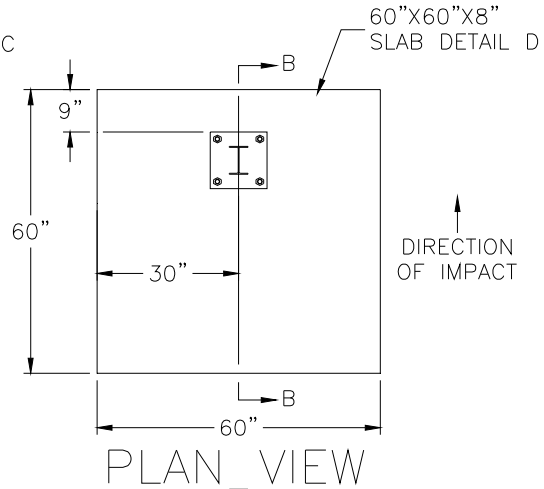
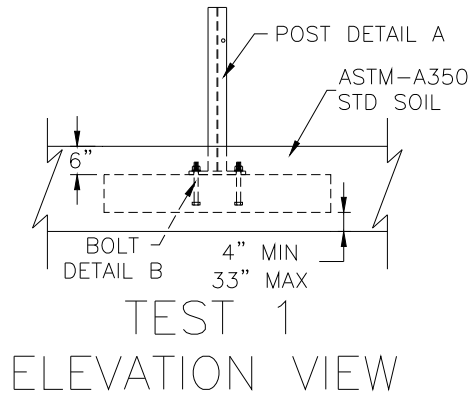
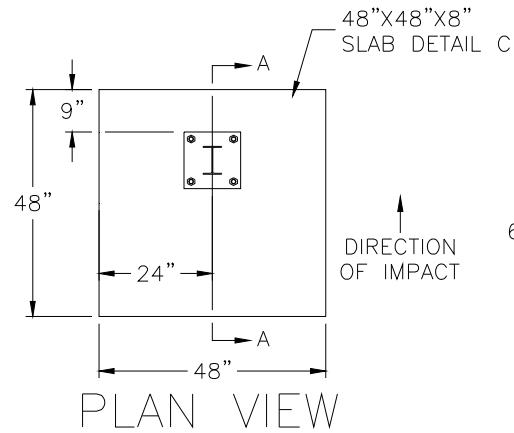

| | | | | | | | |
|---------------------------------|------------|-----|------|--|------------|------------|-----------|
| The Texas A&M University System | | | | | | | |
| REVISIONS | | | | TEXAS TRANSPORTATION INSTITUTE COLLEGE STATION, TEXAS 77843 | | | |
| NO. | DATE | BY | CHK. | Project No. | Date | Drawn By | Scale |
| 1. | 2009/01/09 | NDE | WW | 405160-12 | 2008/08/07 | NDE | |
| 2. | | | | | | | |
| 3. | | | | | | | |
| 4. | | | | STEEL POST OVER UNDERGROUND STRUCTURES | | | Sheet No. |
| 5. | | | | | | | 1 of 6 |
| APPROVED: | | | | | | 2008/08/07 | |
| WILLIAM WILLIAMS: | | | | | | | |

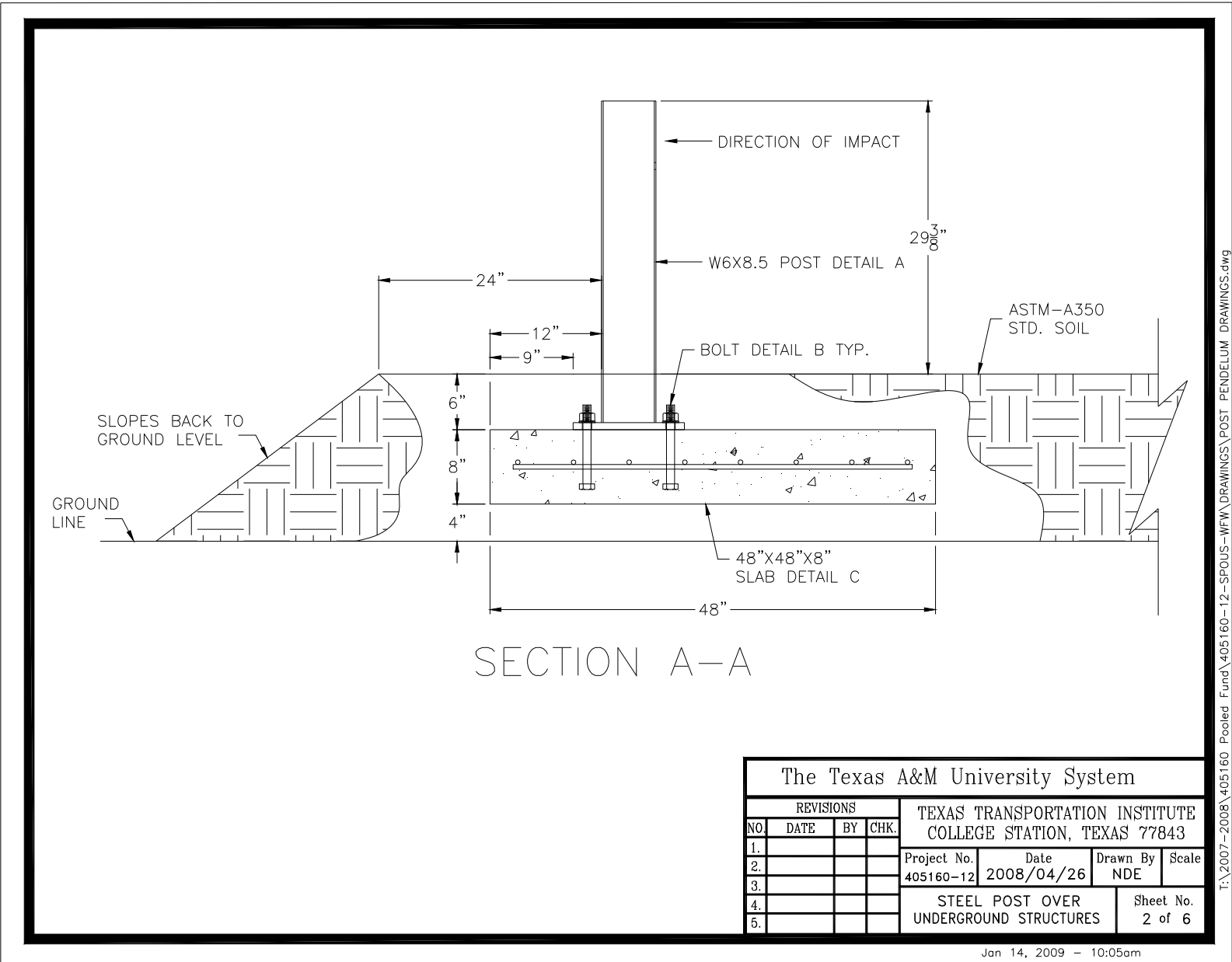

SECTION A-A

| The Texas A&M University System | | | | | | | | | | | | | | | | | | | | | | | | | | | | | | | |
|--|------|-------------|------------|--|-------|-------------|------|----------|-------|----|------|-----------|------------|-----|--|---|--|--|--|---------------------|--|--|--|----|--|--|--|----|--|--|--|
| <table border="1"> <thead> <tr> <th colspan="4">REVISIONS</th> </tr> <tr> <th>NO.</th> <th>DATE</th> <th>BY</th> <th>CHK.</th> </tr> </thead> <tbody> <tr> <td>1.</td> <td></td> <td></td> <td></td> </tr> <tr> <td>2.</td> <td></td> <td></td> <td></td> </tr> <tr> <td>3.</td> <td></td> <td></td> <td></td> </tr> <tr> <td>4.</td> <td></td> <td></td> <td></td> </tr> <tr> <td>5.</td> <td></td> <td></td> <td></td> </tr> </tbody> </table> | | | | REVISIONS | | | | NO. | DATE | BY | CHK. | 1. | | | | 2. | | | | 3. | | | | 4. | | | | 5. | | | |
| REVISIONS | | | | | | | | | | | | | | | | | | | | | | | | | | | | | | | |
| NO. | DATE | BY | CHK. | | | | | | | | | | | | | | | | | | | | | | | | | | | | |
| 1. | | | | | | | | | | | | | | | | | | | | | | | | | | | | | | | |
| 2. | | | | | | | | | | | | | | | | | | | | | | | | | | | | | | | |
| 3. | | | | | | | | | | | | | | | | | | | | | | | | | | | | | | | |
| 4. | | | | | | | | | | | | | | | | | | | | | | | | | | | | | | | |
| 5. | | | | | | | | | | | | | | | | | | | | | | | | | | | | | | | |
| <table border="1"> <tr> <td colspan="2">TEXAS TRANSPORTATION INSTITUTE COLLEGE STATION, TEXAS 77843</td> <td>Project No.</td> <td>Date</td> <td>Drawn By</td> <td>Scale</td> </tr> <tr> <td colspan="2"></td> <td>405160-12</td> <td>2008/04/26</td> <td>NDE</td> <td></td> </tr> <tr> <td colspan="4">STEEL POST OVER UNDERGROUND STRUCTURES</td> <td colspan="2">Sheet No. 2 of 6</td> </tr> </table> | | | | TEXAS TRANSPORTATION INSTITUTE COLLEGE STATION, TEXAS 77843 | | Project No. | Date | Drawn By | Scale | | | 405160-12 | 2008/04/26 | NDE | | STEEL POST OVER UNDERGROUND STRUCTURES | | | | Sheet No. 2 of 6 | | | | | | | | | | | |
| TEXAS TRANSPORTATION INSTITUTE COLLEGE STATION, TEXAS 77843 | | Project No. | Date | Drawn By | Scale | | | | | | | | | | | | | | | | | | | | | | | | | | |
| | | 405160-12 | 2008/04/26 | NDE | | | | | | | | | | | | | | | | | | | | | | | | | | | |
| STEEL POST OVER UNDERGROUND STRUCTURES | | | | Sheet No. 2 of 6 | | | | | | | | | | | | | | | | | | | | | | | | | | | |

Jan 14, 2009 - 10:05am

I:\2007-2008\Fund\405160-12-SPOUS-WFW\DRAWINGS\POST_PENDELUM_DRAWINGS.dwg

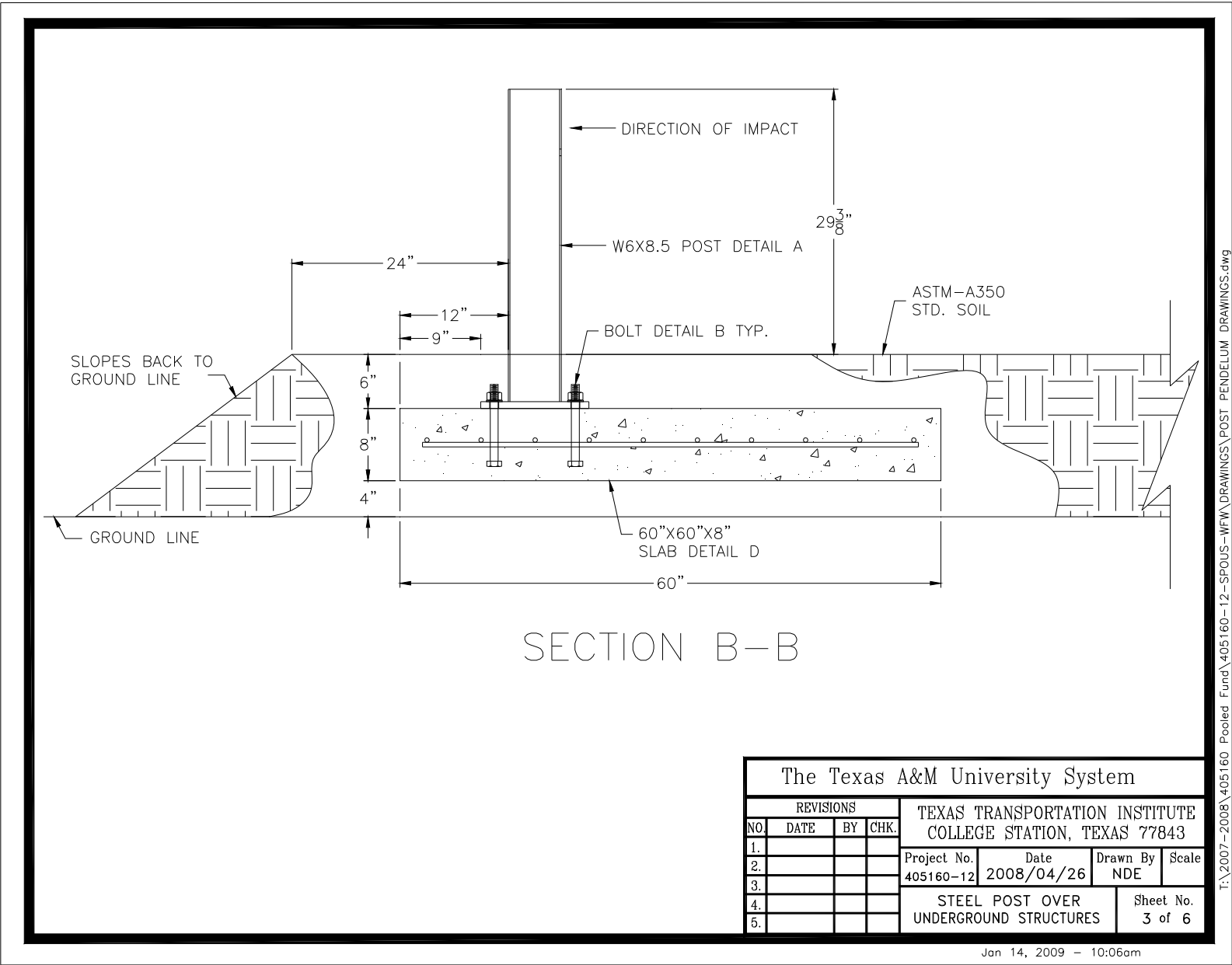

| | | | |
|--|------|------------|---------------------|
| The Texas A&M University System | | | |
| TEXAS TRANSPORTATION INSTITUTE COLLEGE STATION, TEXAS 77843 | | | |
| Project No. | | Date | Drawn By |
| 405160-12 | | 2008/04/26 | NDE |
| STEEL POST OVER UNDERGROUND STRUCTURES | | | Sheet No. 3 of 6 |
| REVISIONS | | | |
| NO. | DATE | BY | CHK. |
| 1. | | | |
| 2. | | | |
| 3. | | | |
| 4. | | | |
| 5. | | | |

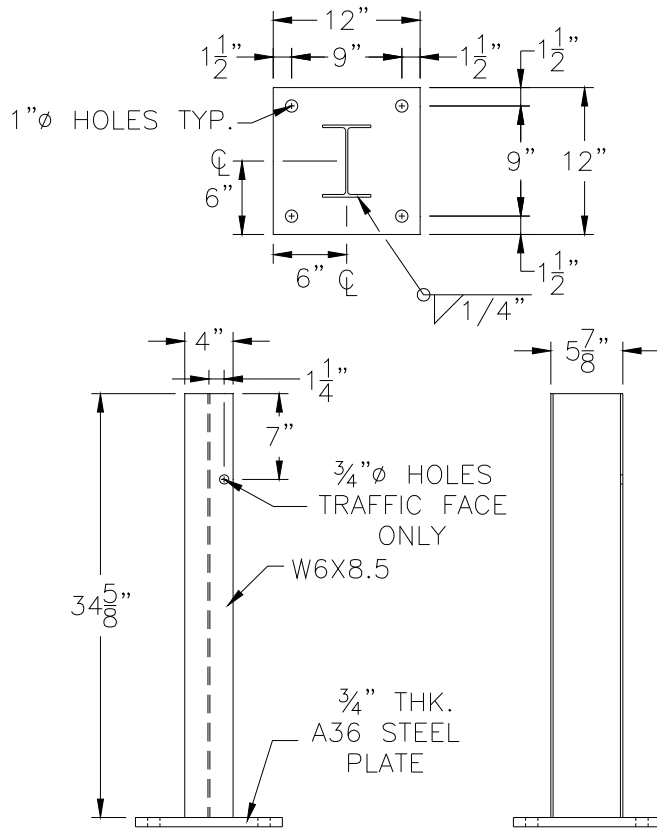

POST DETAIL A

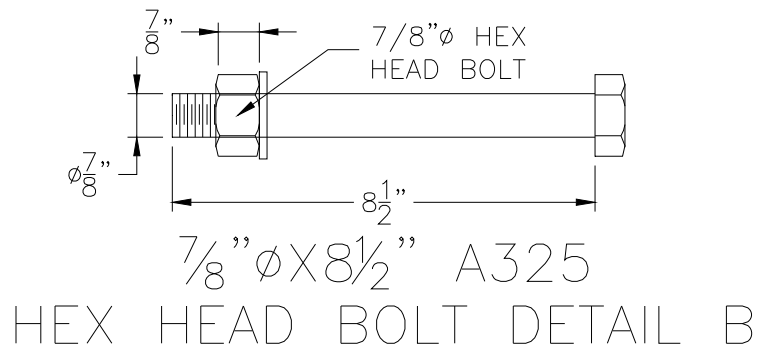

The Texas A&M University System

| REVISIONS | | | | TEXAS TRANSPORTATION INSTITUTE COLLEGE STATION, TEXAS 77843 | | | |
|-----------|------------|-----|-----|--|------------|----------|-------|
| NO. | DATE | BY | CHK | Project No. | Date | Drawn By | Scale |
| 1. | 2009/01/09 | NDE | WW | 405160-12 | 2008/04/26 | NDE | |
| 2. | | | | | | | |
| 3. | | | | | | | |
| 4. | | | | | | | |
| 5. | | | | | | | |

STEEL POST OVER UNDERGROUND STRUCTURES
Sheet No. 4 of 6

Jan 14, 2009 - 10:08am

T:\2007-2008\405160 Pooled Fund\405160-12-SP0US-WFW\DRAWINGS\POST PENDELUM DRAWINGS.dwg

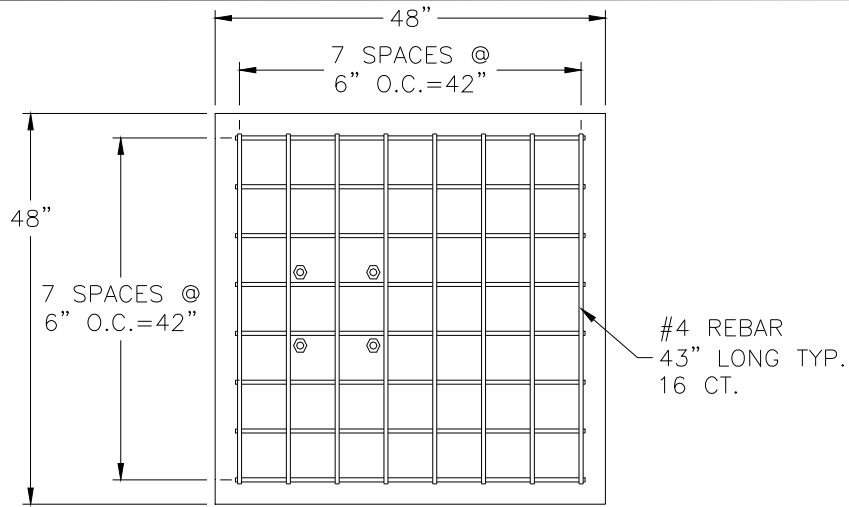

TOP VIEW
BOLT DETAIL B

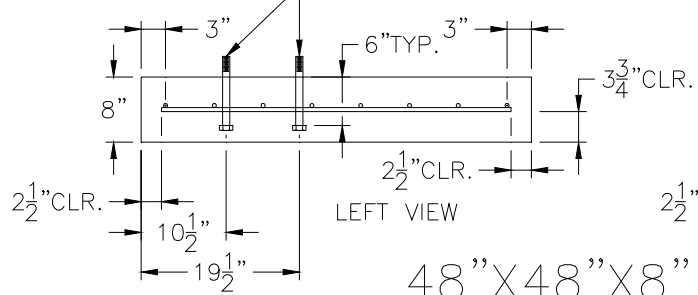

LEFT VIEW

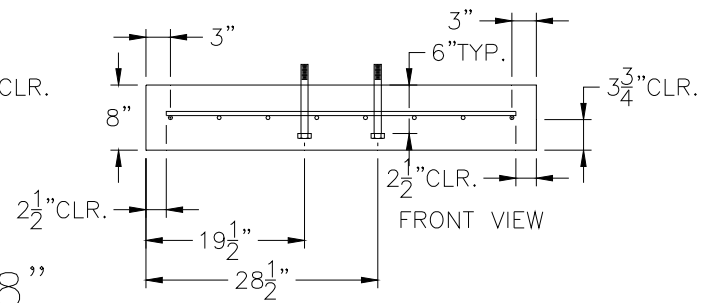

FRONT VIEW

48" X 48" X 8"
SLAB DETAIL C

| | | | | | | | |
|-----------|------------|-----|------|--|------------|----------|-----------|
| REVISIONS | | | | The Texas A&M University System | | | |
| | | | | TEXAS TRANSPORTATION INSTITUTE COLLEGE STATION, TEXAS 77843 | | | |
| NO. | DATE | BY | CHK. | Project No. | Date | Drawn By | Scale |
| 1. | 2009/01/09 | NDE | WW | 405160-12 | 2008/04/26 | NDE | |
| 2. | | | | | | | |
| 3. | | | | | | | |
| 4. | | | | STEEL POST OVER UNDERGROUND STRUCTURES | | | Sheet No. |
| 5. | | | | | | | 5 of 6 |

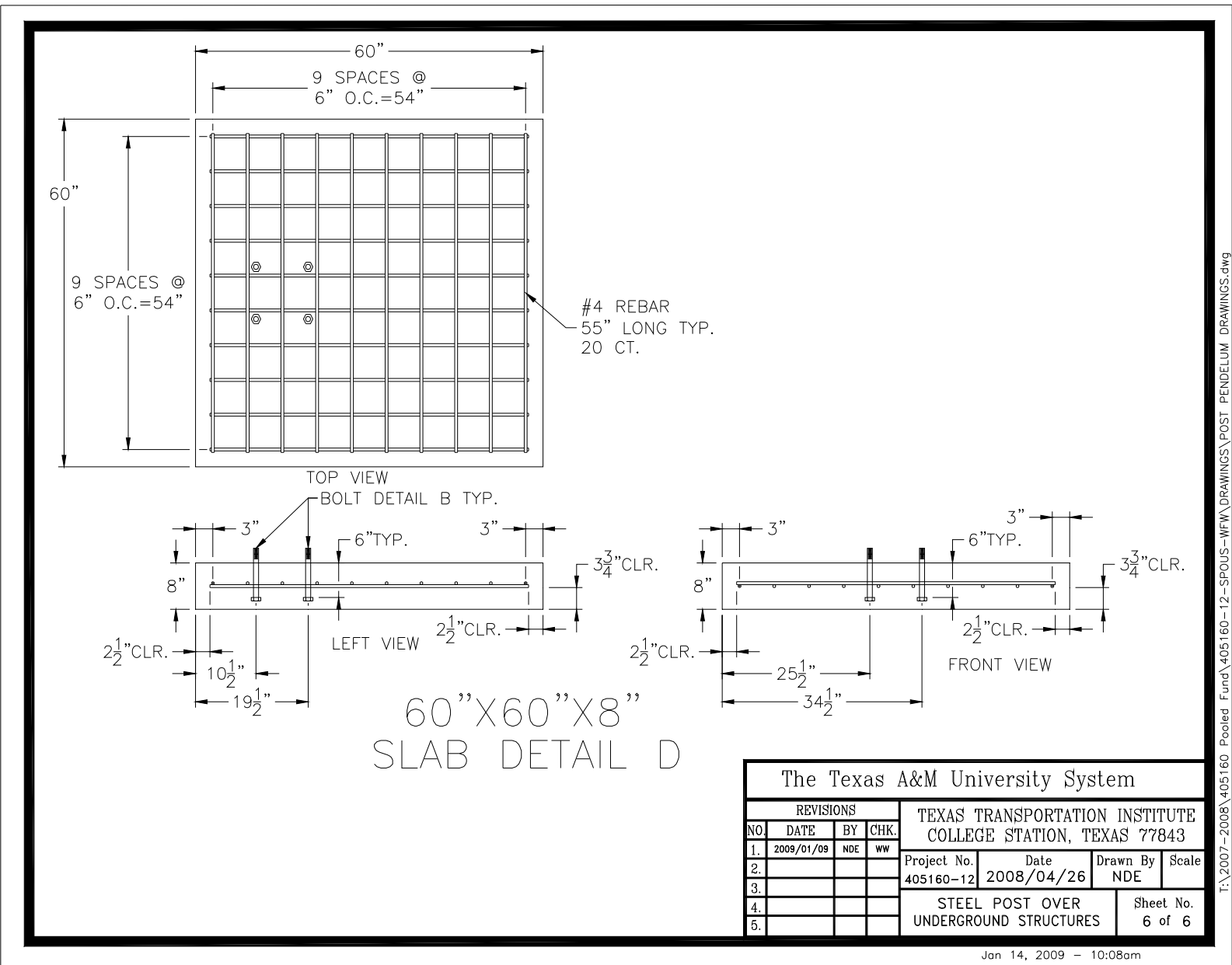

| | | | |
|--|------------|---|--------------------|
| The Texas A&M University System | | | |
| REVISIONS | | | |
| NO. | DATE | BY | CHK. |
| 1. | 2009/01/09 | NDE | WW |
| 2. | | | |
| 3. | | | |
| 4. | | | |
| 5. | | | |
| TEXAS TRANSPORTATION INSTITUTE COLLEGE STATION, TEXAS 77843 | | Project No. 405160-12 | Date 2008/04/26 |
| | | Drawn By NDE | Scale |
| | | STEEL POST OVER UNDERGROUND STRUCTURES | |
| | | Sheet No. 6 of 6 | |

I:\2007-2008\405160 Pooled Fund\405160-12-SPOUS-WFW\DRAWINGS\POST PENDELUM DRAWINGS.dwg

ATTACHMENT D. PHOTOGRAPHS OF TESTING



Figure D1. Steel posts over underground structure with 60-inch concrete footing before test 405160-12 P1.

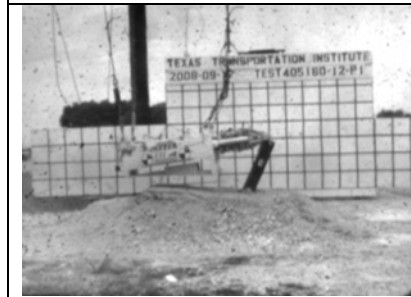

Figure D2. Steel posts over underground structure with 60-inch concrete footing after test 405160-12 P1.

Table D1. Summary of results for pendulum test 405160-12 P1.



0.000 s



0.146 s



0.289 s



0.434 s

General Information

Test Agency..... Texas Transportation Institute
 Test No. 405160-12 P1
 Date 2008-09-17

Test Article

Type..... Steel Posts over Underground Structures
 Installation Height (m)..... 28.5 inches
 Material of Key Element W6x8.5 steel post

Soil Type..... 60-inch Concrete footing in Standard Soil

Test Vehicle

Type..... Bogie
 Designation..... Pendulum
 Test Inertia Mass 839 kg

Impact Conditions

Speed 21.6 mi/h
 Angle 90 deg

Occupant Risk Values

Impact Velocity
 Longitudinal direction..... 24.6 ft/s (7.5 m/s)
 Ridedown Accelerations
 Longitudinal direction..... -3.6 g's

Maximum Change in Velocity 19.2 ft/s

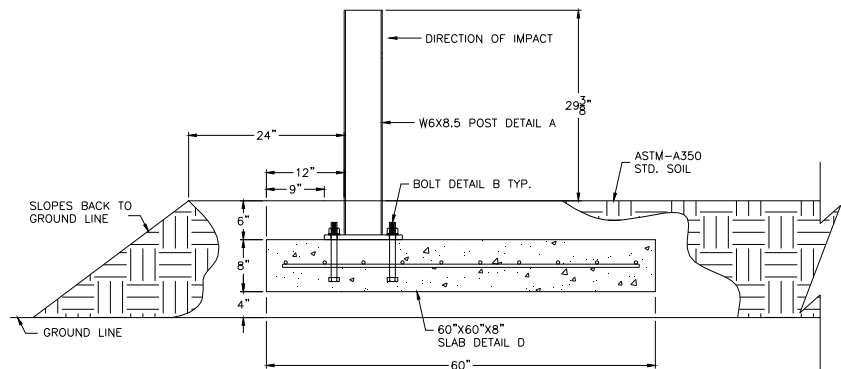



Figure D3. Steel posts over underground structure with 48-inch concrete footing before test 405160-12 P2.



Figure D4. Steel posts over underground structure with 48-inch concrete footing after test 405160-12 P2.

Table D2. Summary of results for pendulum test 405160-12 P2.



0.000 s



0.178 s



0.351 s



0.535 s

General Information

Test Agency..... Texas Transportation Institute
 Test No. 405160-12 P2
 Date 2008-09-17

Test Article

Type..... Steel Posts over Underground Structures
 Installation Height (m)..... 28.5 inches
 Material of Key Element W6x8.5 steel post

Soil Type..... 48-inch Concrete footing in Standard Soil

Test Vehicle

Type..... Bogie
 Designation..... Pendulum
 Test Inertia Mass 839 kg

Impact Conditions

Speed 21.5 mi/h
 Angle 90 deg

Occupant Risk Values

Impact Velocity
 Longitudinal direction..... 20.7 ft/s (6.3 m/s)
 Ridedown Accelerations
 Longitudinal direction..... -2.9 g's

Maximum Change in Velocity 20.1 ft/s

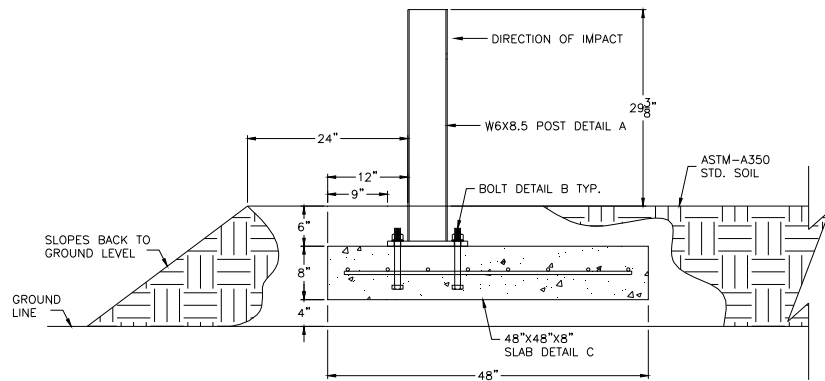

ATTACHMENT E. ACCELERATION AND FORCE TRACES

Pendulum Test No. 405160-12 P1 -- 60-inch Concrete Foundation

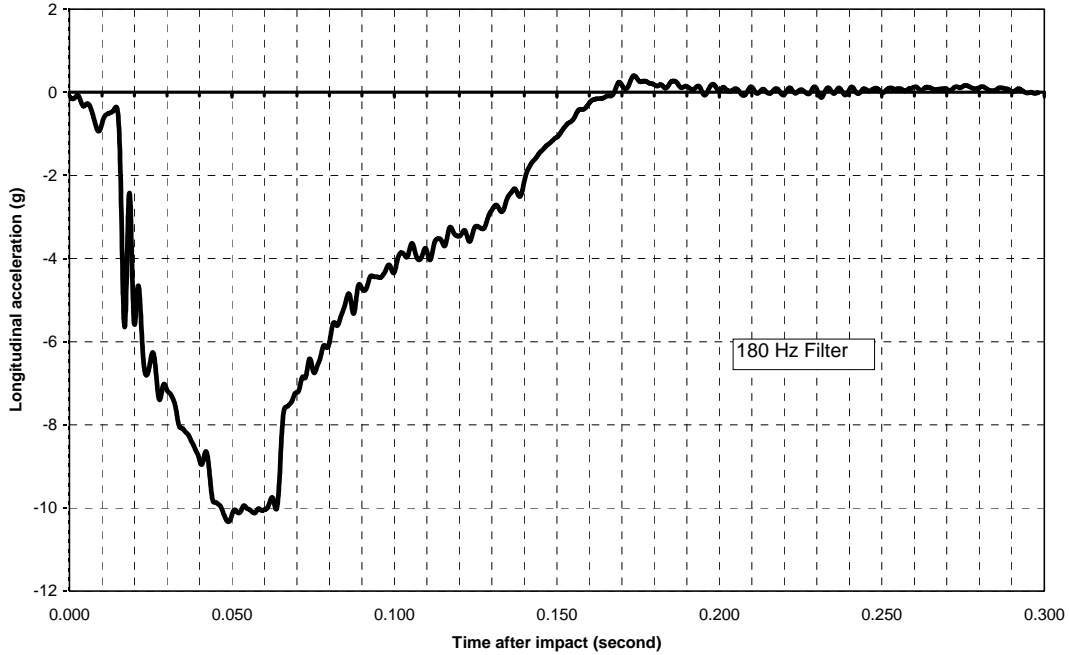

Figure E1. Accelerometer trace for test 405160-12 P1.

Pendulum Test No. 405160-12 P1 -- 60-inch Concrete Foundation

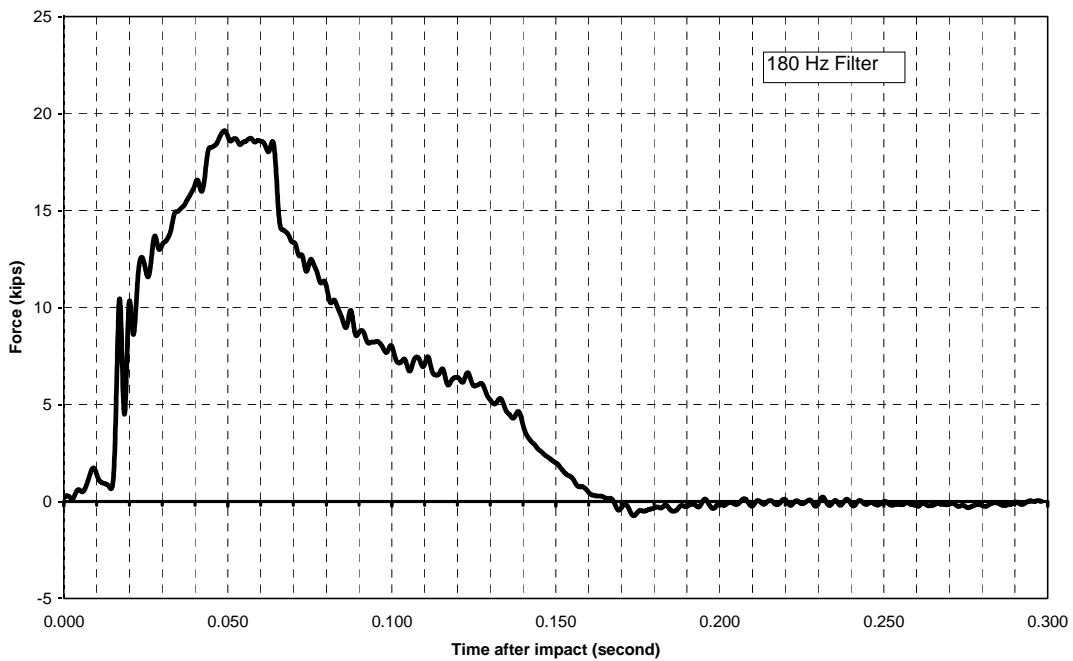

Figure E2. Force trace for test 405160-12 P1.

Pendulum Test No. 405160-12 P2 -- 48-inch Concrete Foundation

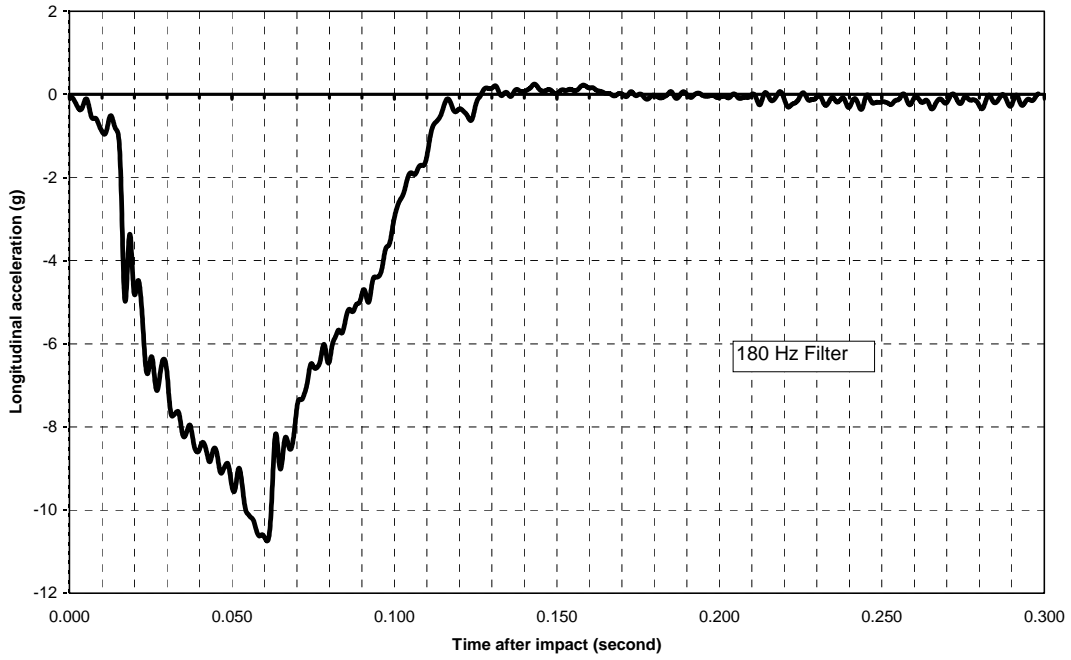

Figure E3. Accelerometer trace for test 405160-12 P2.

Pendulum Test No. 405160-12 P2 -- 48-inch Concrete Foundation

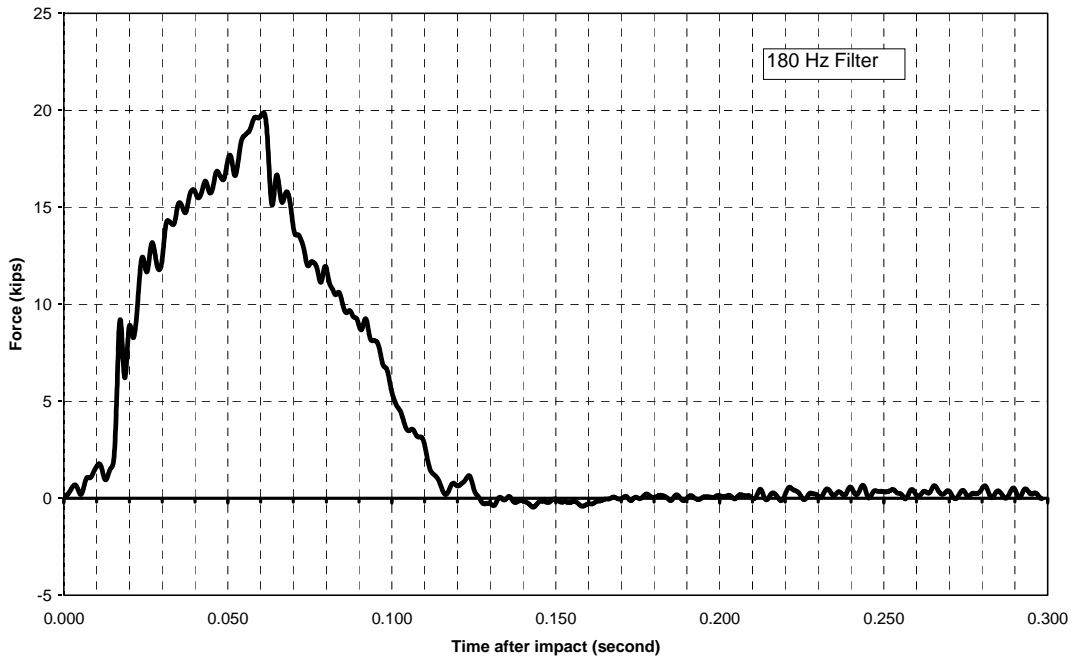

Figure E4. Force trace for test 405160-12 P2.