



U.S. Department
of Transportation
**Federal Highway
Administration**

March 29, 2011

1200 New Jersey Ave., SE
Washington, D.C. 20590

In Reply Refer To:
HSST/B-218

Mr. Paul Fossier, P.E.
Assistant Bridge Design Administrator
Louisiana Department of Transportation and Development
Bridge and Structural Design Section, Rm. 608J
Baton Rouge, LA 70804-9245

RECEIVED

APR 01 2011

BRIDGE DESIGN

Dear Mr. Fossier:

This letter is in response to your request for Federal Highway Administration (FHWA) acceptance of a roadside safety system for use on the National Highway System (NHS).

Name of system: F-Shape Reinforced Concrete Barrier with Slotted Drain Holes
Type of system: Permanent F-Shape Reinforced Concrete Barrier
Test Level: National Cooperative Highway Research Program (NCHRP) Report 350
Test Level 4 (TL-4)
Testing conducted by: Texas Transportation Institute (TTI)
Date of Request: December 9, 2010
Drawing Designator: SBC04d

You requested that we find this system acceptable for use on the NHS under the provisions of the NCHRP Report 350 "Recommended Procedures for the Safety Performance Evaluation of Highway Features."

Requirements

Roadside safety systems should meet the guidelines contained in the NCHRP Report 350. FHWA memorandum "ACTION: Identifying Acceptable Highway Safety Features" of July 25, 1997, provides further guidance on crash testing requirements of longitudinal barriers.

Decision

The following device was found acceptable, with details provided below:

- F-Shape Reinforced Concrete Barrier with Slotted Drain Holes

Description

The Louisiana Department of Transportation and Development (La DOTD) currently uses a cast-in-place concrete bridge rail on Louisiana bridges. The F-Shape bridge rail is 32 inches in height and 13.25 inches wide at the base. Presently, for bridges that use this concrete F-Shape bridge rail, drainage is provided only at the ends of the bridge since there is no opening provided



through the bridge rail. La DOTD has proposed the use of 6 inches high x 24 inches long open slots located 10 feet apart at the base of the rail to accommodate drainage through the railing. Details of the proposed bridge rail are provided as enclosure to this correspondence.

Crash Testing

The proposed La DOTD F-Shape Reinforced Concrete Barrier with Slotted Drain Holes (barrier) was analyzed at the test facilities at the TTI Proving Grounds Riverside Campus. The analysis was to evaluate the geometry and placement of the drainage slots on the barrier with respect to vehicle impact performance requirements for the NCHRP Report 350, TL-4 specifications.

The proposed drainage slot details were compared with other barriers systems utilizing similar type slots. This review consisted of comparisons with the Texas Department of Transportation (TXDOT) Single Slope Concrete Barrier (Wildlife Crossing) Precast SSCB (TXDOT Wildlife Crossing Barrier) and the Washington Pin & Loop Barrier System designed and successfully crash tested by TTI for the Washington State Department of Transportation (acceptance letter HSSD/B-206). The TTI researchers performed a similar review of the TXDOT Wildlife Crossing Barrier for TXDOT with respect to the size and potential interaction of these openings with respect to the small car and pickup truck for the NCHRP Report 350 crashworthiness criteria.

The potential for vehicular interaction with the barrier was evaluated with respect to the criteria in the AASHTO LRFD Bridge Design Specifications (AASHTO). Two figures are presented in the AASHTO that provide general guidelines for the crash performance of barrier that contain openings or penetrations. These figures provide guidelines for the preferred post set-back from the face of the railing elements and the preferred ratio of the rail contact widths to the overall height of the bridge rail system (see AASHTO Figures A13.1.1-2-Potential for Wheel, Bumper, or Hood Impact with a Post; and, A13.1.1-3-Post Setback Criteria). The potential for wheel interaction with the opening in the barrier was investigated. For the proposed barrier design, the post setback from the face of the rail elements was considered to be zero (0) inches. The maximum vertical clear opening distance between the bridge top of the bridge deck and the top of the opening is 7-5/8 inches. Based on this information and the information provided in AASHTO Figure A13.1.1-2, the clear opening height of 7-5/8 inches presents a low potential for vehicular interaction with the opening in the barrier during a vehicular crash.

The ratio in height of the contact length of the F-Shape Barrier to 32 inches total height of rail (i.e., rail contact width to height) is 0.762. Based on the proposed barrier geometry and the information provided in AASHTO Figure A13.1.1-3, the proposed barrier is considered marginal.

Findings

The analysis of the drainage slot used in the Washington State Department of Transportation Pin & Loop Barrier (WSDOT barrier) appeared to perform well in LS-DYNA impact simulations with both the small car and pickup truck. Although the WSDOT barrier did not meet the AASHTO Manual for Assessing Safety Hardware test specifications, the 9-inch high drainage slot specified used in the WSDOT barrier system did not adversely affect the performance of the crash vehicle. In addition, the potential for vehicle interaction with the drainage slot opening was considered low to marginal with respect to the criteria as provided in

AASHTO Section 13 specifications. Based upon the researchers' analysis, the F-Shape barrier with drainage slots is considered acceptable with respect to Report 350 TL-4 performance criteria.

Details including a side-by-side comparison between size openings of TXDOT Wildlife Crossing Barrier, WSDOT barrier, and LaDOTD F-Shape Barrier with drainage slots are provided as enclosure to this correspondence.

Therefore, the system as described in the request above and detailed in the enclosed drawings is acceptable for use on the NHS under the range of conditions tested, when such use is acceptable to a highway agency.

Please note the following standard provisions that apply to FHWA letters of acceptance:

- This acceptance is limited to the crashworthiness characteristics of the system and does not cover their structural features, nor conformity with the Manual on Uniform Traffic Control Devices.
- Any changes that may adversely influence the crashworthiness of the system will require a new acceptance letter.
- Should FHWA discover that the qualification testing was flawed, that in-service performance reveals unacceptable safety problems, or that the system being marketed is significantly different from the version that was crash tested, we reserve the right to modify or revoke our acceptance.
- You will be expected to supply potential users with sufficient information on design and installation requirements to ensure proper performance.
- You will be expected to certify to potential users that the hardware furnished has essentially the same chemistry, mechanical properties, and geometry as that submitted for acceptance, and that it will meet the crashworthiness requirements of the FHWA and the NCHRP Report 350.
- To prevent misunderstanding by others, this letter of acceptance is designated as number B-218 and shall not be reproduced except in full. This letter and the test documentation upon which it is based are public information. All such letters and documentation may be reviewed at our office upon request.
- This acceptance letter shall not be construed as authorization or consent by the FHWA to use, manufacture, or sell any patented system for which the applicant is not the patent holder. The acceptance letter is limited to the crashworthiness characteristics of the candidate system, and the FHWA is neither prepared nor required to become involved in issues concerning patent law. Patent issues, if any, are to be resolved by the applicant.

Sincerely yours,



Michael S. Griffith
Director, Office of Safety Technologies
Office of Safety

Enclosures

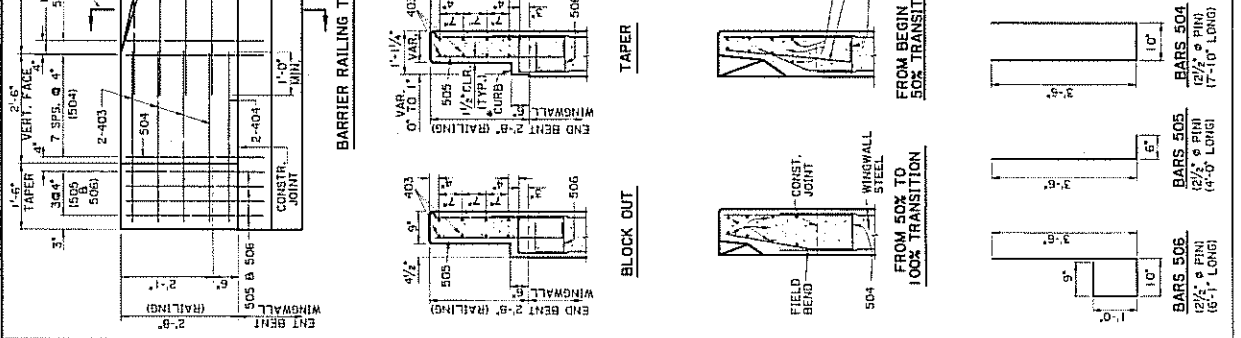
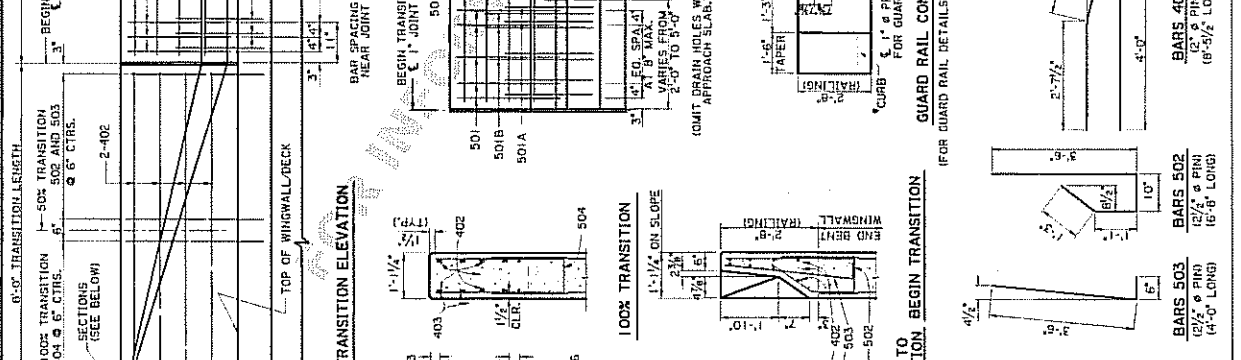
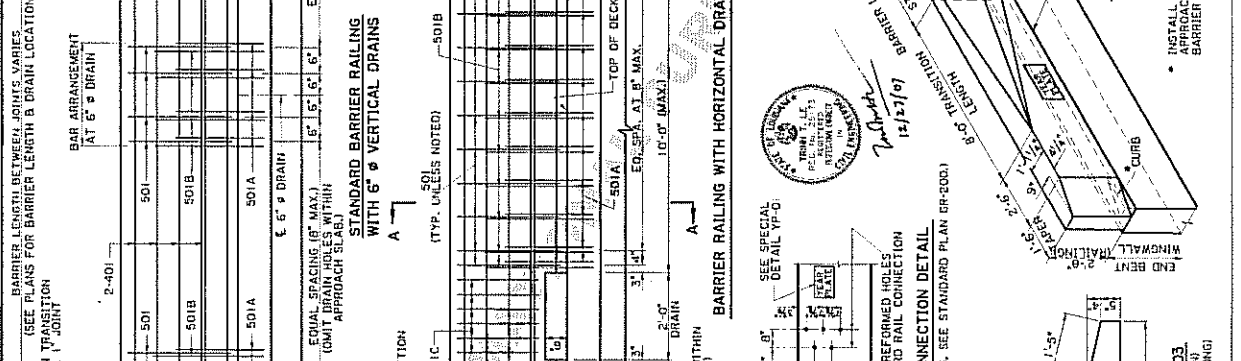
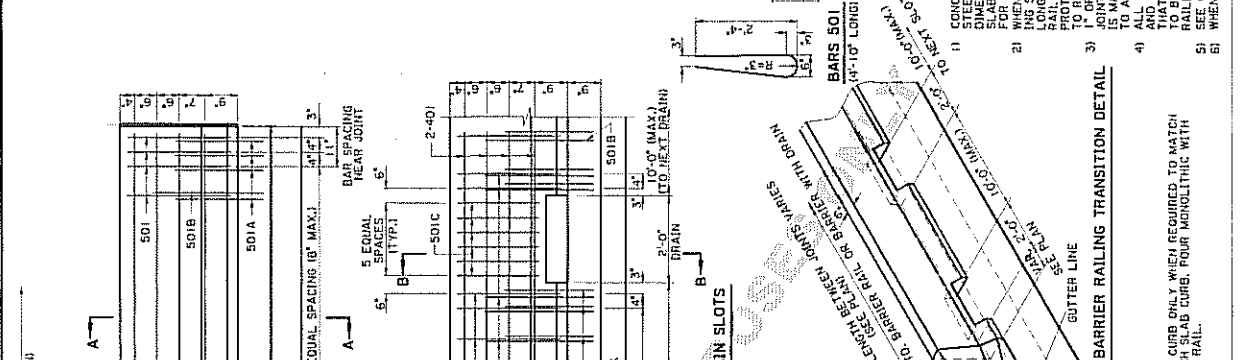
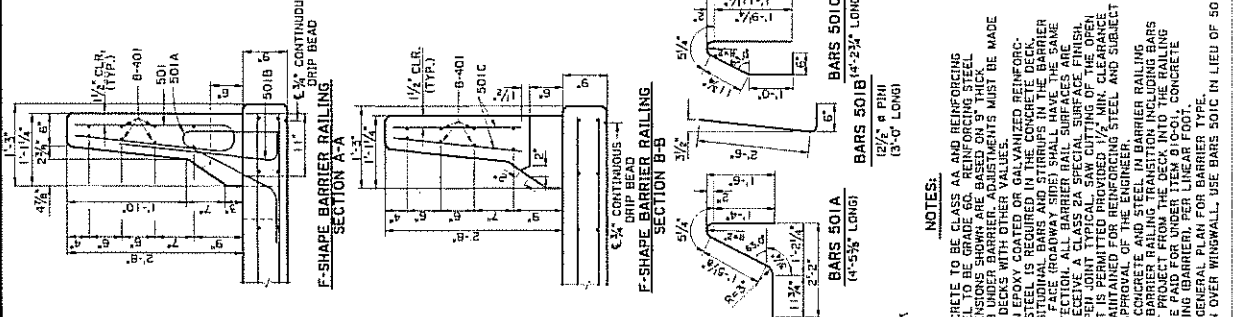

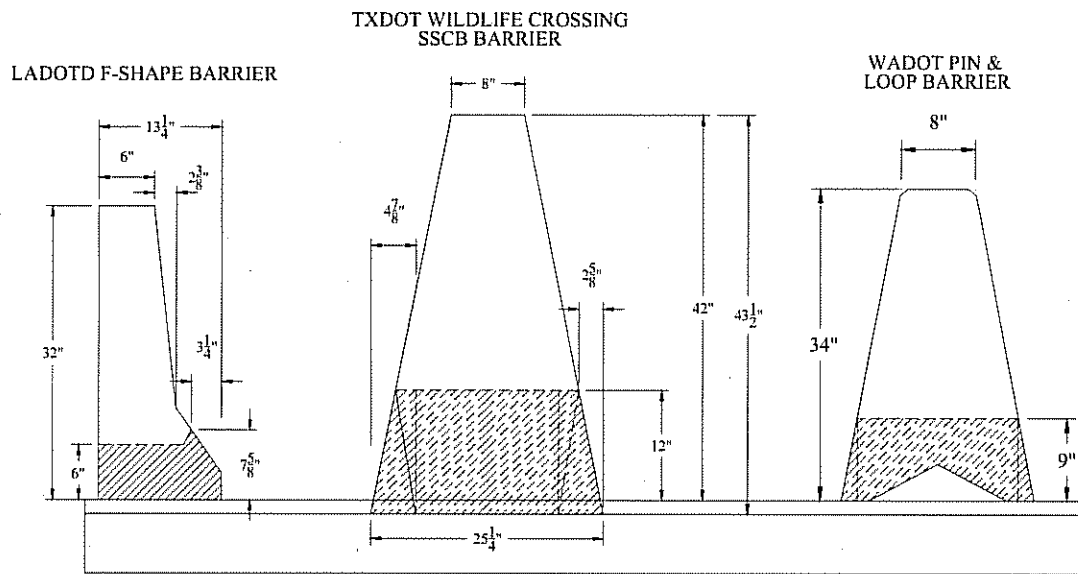

Figure 76 – LaDOTD F-Shape Barrier, TXDOT Wildlife Crossing Barrier WSDOT Pin & Loop Barrier Cross-Sections