



MASH TEST 3-11 ON THE 5-INCH CIPD BARRIER ANCHORS



Crash testing performed at:
TTI Proving Ground
3100 SH 47, Building 7091
Bryan, TX 77807

Test Report 9-1002-7

Cooperative Research Program

**TEXAS TRANSPORTATION INSTITUTE
THE TEXAS A&M UNIVERSITY SYSTEM
COLLEGE STATION, TEXAS**

TEXAS DEPARTMENT OF TRANSPORTATION

in cooperation with the
Federal Highway Administration and the
Texas Department of Transportation
<http://tti.tamu.edu/documents/9-1002-7.pdf>

1. Report No. FHWA/TX-12/9-1002-7		2. Government Accession No.		3. Recipient's Catalog No.	
4. Title and Subtitle MASH TEST 3-11 ON THE 5-INCH CIPD BARRIER ANCHORS				5. Report Date October 2011 Published: December 2011	
				6. Performing Organization Code	
7. Author(s) Dusty R. Arrington, Roger P. Bligh, and Wanda L. Menges				8. Performing Organization Report No. Test Report 9-1002-7	
9. Performing Organization Name and Address Texas Transportation Institute Proving Ground The Texas A&M University System College Station, Texas 77843-3135				10. Work Unit No. (TRAIS)	
				11. Contract or Grant No. Project 9-1002	
12. Sponsoring Agency Name and Address Texas Department of Transportation Research and Technology Implementation Office P.O. Box 5080 Austin, Texas 78763-5080				13. Type of Report and Period Covered Test Report: September 2010–August 2011	
				14. Sponsoring Agency Code	
15. Supplementary Notes Project performed in cooperation with the Texas Department of Transportation and the Federal Highway Administration. Project Title: Roadside Safety Device Crash Testing Program URL: http://tti.tamu.edu/documents/9-1002-7.pdf					
16. Abstract <p>A full-scale crash test was performed to evaluate the impact performance of a Texas T223 concrete beam and post bridge rail anchored to a 5-inch cast-in-place deck (CIPD). The testing followed the <i>MASH</i> standards for Test Level 3 (TL-3) longitudinal barriers. The test performed was American Association of State Highways and Transportation Officials (AAHSTO) <i>Manual for Assessing Safety Hardware (MASH)</i> test 3-11, which involves a 2270P (5000 lb) pickup truck impacting the critical impact point (CIP) of the barrier at a nominal impact speed and angle of 62 mi/h and 25 degrees, respectively. This test evaluated the strength of the barrier and its anchorage to the 5-inch CIPD.</p> <p>The T223 bridge rail anchored to a 5-inch CIPD successfully met all required <i>MASH</i> evaluation criteria. The rail anchorage withstood the design impact without any visible distress. The rail anchorage detail is considered suitable for implementation when concrete bridge rails are attached to 5-inch decks cast on prestressed box and slab beams. The anchorage detail is considered acceptable for use with the T223 bridge rail, other concrete bridge rails, and metal rails mounted on concrete parapets.</p>					
17. Key Words Bridge Rails, Rail Anchors, Crash Testing, Roadside Safety			18. Distribution Statement No restrictions. This document is available to the public through NTIS: National Technical Information Service Alexandria, Virginia 22312 http://www.ntis.gov		
19. Security Classif.(of this report) Unclassified		20. Security Classif.(of this page) Unclassified		21. No. of Pages 82	22. Price

**MASH TEST 3-11 ON THE 5-INCH CIPD
BARRIER ANCHORS**

by

Dusty R. Arrington
Engineering Research Associate
Texas Transportation Institute

Roger P. Bligh, Ph.D., P.E.
Research Engineer
Texas Transportation Institute

and

Wanda L. Menges
Research Specialist
Texas Transportation Institute Proving Ground

Report 9-1002-7
Project 9-1002
Project Title: Roadside Safety Device Crash Testing Program

Performed in cooperation with the
Texas Department of Transportation
and the
Federal Highway Administration

October 2011
Published: December 2011

TEXAS TRANSPORTATION INSTITUTE
The Texas A&M University System
College Station, Texas 77843-3135

DISCLAIMER

This research was performed in cooperation with the Texas Department of Transportation (TxDOT) and the Federal Highway Administration (FHWA). The contents of this report reflect the views of the authors, who are responsible for the facts and the accuracy of the data presented herein. The contents do not necessarily reflect the official view or policies of the FHWA or TxDOT. This report does not constitute a standard, specification, or regulation, and its contents are not intended for construction, bidding, or permit purposes. In addition, the above listed agencies assume no liability for its contents or use thereof. The United States Government and the State of Texas do not endorse products or manufacturers. Trade or manufacturers' names appear herein solely because they are considered essential to the object of this report. The engineer in charge of the project was Roger P. Bligh, P.E. (Texas, #78550).

TTI PROVING GROUND DISCLAIMER

The results of the crash testing reported herein apply only to the article being tested.

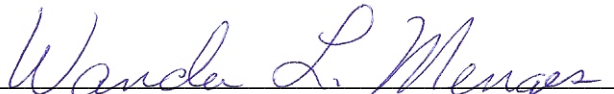

Wanda L. Menges, Research Specialist
Deputy Quality Manager

Richard A. Zimmer, Senior Research Specialist
Test Facility Manager
Quality Manager
Technical Manager

ACKNOWLEDGMENTS

This research project was conducted under a cooperative program between the Texas Transportation Institute, the Texas Department of Transportation, and the Federal Highway Administration. The TxDOT project director for this research was Rory Meza, P.E., Design Division. John Holt, P.E., and Jon Reis with the Bridge Division served as project advisors and were also actively involved in this research. The TxDOT research engineer was Wade Odell, P.E. with the Research and Technology Implementation Office. The authors acknowledge and appreciate their guidance and assistance.

TABLE OF CONTENTS

	Page
LIST OF FIGURES	ix
LIST OF TABLES.....	x
CHAPTER 1. INTRODUCTION	1
1.1 INTRODUCTION	1
1.2 OBJECTIVES/SCOPE OF RESEARCH	1
CHAPTER 2. BARRIER SELECTION AND DESIGN MODIFICATIONS	3
2.1 BARRIER SELECTION	3
2.2 T223 BARRIER HISTORY	5
2.3 T223 ANCHORAGE MODIFICATIONS	5
CHAPTER 3. EVALUATION OF <i>MASH</i> TESTING MATRIX	7
3.1 OBJECTIVES OF TESTING	7
3.2 TEST MATRIX	7
3.2.1 MASH Test 3-10.....	7
3.2.2 MASH Test 3-11.....	7
3.3 DETERMINATION OF CRITICAL IMPACT LOCATION	8
CHAPTER 4. SYSTEM DETAILS.....	9
4.1 TEST ARTICLE DESIGN AND CONSTRUCTION.....	9
4.2 SIMULATED PRESTRESSED BOX BEAM	9
4.3 5-INCH CAST-IN-PLACE DECK.....	11
4.4 T223 BARRIER.....	11
4.5 MATERIAL SPECIFICATIONS	12
CHAPTER 5. TEST REQUIREMENTS AND EVALUATION CRITERIA.....	17
5.1 CRASH TEST CONDITIONS	17
5.2 EVALUATION CRITERIA	17
CHAPTER 6. CRASH TEST PROCEDURES	19
6.1 TEST FACILITY	19
6.2 VEHICLE TOW AND GUIDANCE PROCEDURES.....	19
6.3 DATA ACQUISITION SYSTEMS.....	19
6.3.1 Vehicle Instrumentation and Data Processing	19
6.3.2 Anthropomorphic Dummy Instrumentation	20
6.3.3 Photographic Instrumentation and Data Processing	20
CHAPTER 7. CRASH TEST RESULTS	21
7.1 TEST DESIGNATION AND ACTUAL IMPACT CONDITIONS	21
7.2 TEST VEHICLE.....	21

TABLE OF CONTENTS (CONTINUED)

	Page
7.3 WEATHER CONDITIONS.....	21
7.4 TEST DESCRIPTION	21
7.5 DAMAGE TO TEST INSTALLATION	24
7.6 VEHICLE DAMAGE.....	24
7.7 OCCUPANT RISK FACTORS.....	24
CHAPTER 8. SUMMARY AND CONCLUSIONS.....	31
8.1 ASSESSMENT OF TEST RESULTS	31
8.1.1 Structural Adequacy.....	31
8.1.2 Occupant Risk.....	31
8.1.3 Vehicle Trajectory	32
8.2 CONCLUSIONS.....	32
CHAPTER 9. IMPLEMENTATION STATEMENT.....	35
REFERENCES	37
APPENDIX A. DETAILS OF THE TxDOT 5-INCH CIPD BARRIER ANCHOR INSTALLATION	39
APPENDIX B. CERTIFICATION DOCUMENTATION.....	49
APPENDIX C. TEST VEHICLE PROPERTIES AND INFORMATION.....	55
APPENDIX D. SEQUENTIAL PHOTOGRAPHS.....	59
APPENDIX E. VEHICLE ANGULAR DISPLACEMENTS AND ACCELERATIONS	63

LIST OF FIGURES

	Page
Figure 2.1. TxDOT T223 Barrier.	3
Figure 2.2. Comparison of TxDOT Standard Prestressed Box and Slab Beams.	4
Figure 2.3. Comparison of TxDOT Standard “Z” Bar and Modified “Z” Bar Dimensions.	6
Figure 4.1. Test Article Cross-Section.	10
Figure 4.2. Details of the 5-inch CIPD Barrier Anchor Installation.	13
Figure 4.3. Layout of the 5-inch CIPD Barrier Anchor Installation.	14
Figure 4.4. 5-inch CIPD Barrier Anchor Installation before Test No. 420021-5.....	15
Figure 7.1. Vehicle/Installation Geometrics for Test No. 420021-5.....	22
Figure 7.2. Vehicle before Test No. 420021-5.....	23
Figure 7.3. After Impact Vehicle/Barrier Positions for Test No. 420021-5.....	25
Figure 7.4. Installation after Test No. 420021-5.	26
Figure 7.5. Vehicle after Test No. 420021-5.....	27
Figure 7.6. Interior of Vehicle for Test No. 420021-5.	28
Figure 7.7. Summary of Results for <i>MASH</i> Test 3-11 on the TxDOT 5-inch CIPD Barrier Anchor Installation.....	29
Figure D1. Sequential Photographs for Test No. 420021-5 (Overhead and Frontal Views).	59
Figure D2. Sequential Photographs for Test No. 420021-5 (Rear View).	61
Figure E1. Vehicle Angular Displacements for Test No. 420021-5.....	63
Figure E2. Vehicle Longitudinal Accelerometer Trace for Test No. 420021-5 (Accelerometer Located at Center of Gravity).	64
Figure E3. Vehicle Lateral Accelerometer Trace for Test No. 420021-5 (Accelerometer Located at Center of Gravity).	65
Figure E4. Vehicle Vertical Accelerometer Trace for Test No. 420021-5 (Accelerometer Located at Center of Gravity).	66
Figure E5. Vehicle Longitudinal Accelerometer Trace for Test No. 420021-5 (Accelerometer Located over Rear Axle).	67
Figure E6. Vehicle Lateral Accelerometer Trace for Test No. 420021-5 (Accelerometer Located over Rear Axle).	68
Figure E7. Vehicle Vertical Accelerometer Trace for Test No. 420021-5 (Accelerometer Located over Rear Axle).	69

LIST OF TABLES

	Page
Table 8.1. Performance Evaluation Summary for <i>MASH</i> Test 3-11 on the TxDOT 5-inch CIPD Barrier Anchor Installation.....	33
Table C1. Vehicle Properties for Test No. 420021-5.	55
Table C2. Vehicle Vertical CG Parametric Measurements for Test No. 420021-5.	56
Table C3. Exterior Crush Measurements for Test No. 420021-5.....	57
Table C4. Occupant Compartment Measurements for Test No. 420021-5.	58

CHAPTER 1. INTRODUCTION

1.1 INTRODUCTION

This project was set up to provide Texas Department of Transportation (TxDOT) with a mechanism to quickly and effectively evaluate high priority issues related to roadside safety devices. Roadside safety devices shield motorists from roadside hazards such as non-traversable terrain and fixed objects. To maintain the desired level of safety for the motoring public, these safety devices must be designed to accommodate a variety of site conditions, placement locations, and a change vehicle fleet. Periodically, there is a need to assess the compliance of existing safety devices with current vehicle testing criteria and develop new devices that address identified needs.

Under this project, roadside safety issues are identified and prioritized for investigation. Each roadside safety issue is addressed with a separate work plan, and the results are summarized in an individual test report.

1.2 OBJECTIVES/SCOPE OF RESEARCH

The objective of this project was to develop anchorage details for mounting concrete bridge rails to 5-inch decks cast on prestressed box and slab beams. The strength of the anchorage system was evaluated with a full-scale crash test conducted in accordance with the American Association of State Highway and Transportation Officials (AASHTO) *Manual for Assessing Safety Hardware (MASH)* standards for Test Level 3 (TL-3) longitudinal barriers (I). Test 3-11 was performed on a T223 concrete beam-and-post bridge rail mounted to a 5-inch deck cast in place on a simulated prestressed box beam. *MASH* test 3-11 involves a 2270P (5000 lb) pickup truck impacting the critical impact point of the barrier at a nominal impact speed and angle of 62 mi/h and 25 degrees, respectively.

Reported herein are the details of the anchorage system, a description of the crash test, and an assessment of the test results.

CHAPTER 2. BARRIER SELECTION AND DESIGN MODIFICATIONS

2.1 BARRIER SELECTION

TxDOT commonly utilizes adjacently framed prestressed box and slab beams with composite slabs in rural areas of the state. This study was restricted to evaluating only concrete barrier anchor designs, therefore steel barrier designs were not evaluated under this project. Many of these bridges are at elevations that present a risk of overtopping by streams and rivers during severe flooding events. Therefore, any barrier that is to be installed in this situation must have large openings in its profile to allow for water to flow through the barrier should the bridge be overtopped in a severe flooding event. These openings help reduce transverse loads on the bridge structure and reduce flow restriction caused by the bridge profile.

After evaluation of TxDOT's current barrier standards, only the T223 barrier, shown in Figure 2.1, fits these constraints. This barrier profile is also the primary concrete barrier used by TxDOT in these locations. The selected T223 barrier also provides a worst case for anchorage failure in the event of a vehicle impact when compared to other concrete barrier profiles in TxDOT's current design standards. The narrow thickness and width of the support posts in the T223 design standard provide for a worst case from an anchorage standpoint. The narrow thickness increases the pullout load on the rebar anchors by reducing the moment couple formed by the compression zone of the concrete post and the tension developed in the rebar anchor. The narrow width of the posts localizes the rebar anchors to discrete locations as opposed to being spread along the entire length of the barrier as in a continuous F-shape profile. This again results in an increased load in the rebar anchors.



Figure 2.1. TxDOT T223 Barrier.

Both the standard box and slab beam sections, illustrated in Figure 2.2, were evaluated to determine which would provide the worst case for anchorage of the T223 barrier profile. It was concluded that the 5.5-inch thick top flange of the prestressed concrete box beam made it a worst case for anchorage compared to the 12-inch thick uniform prestressed slab beam. Therefore, a simulated concrete box beam was selected for testing in conjunction with a T223 barrier profile anchored into 5-inch thick composite cast-in-place deck (CIPD).

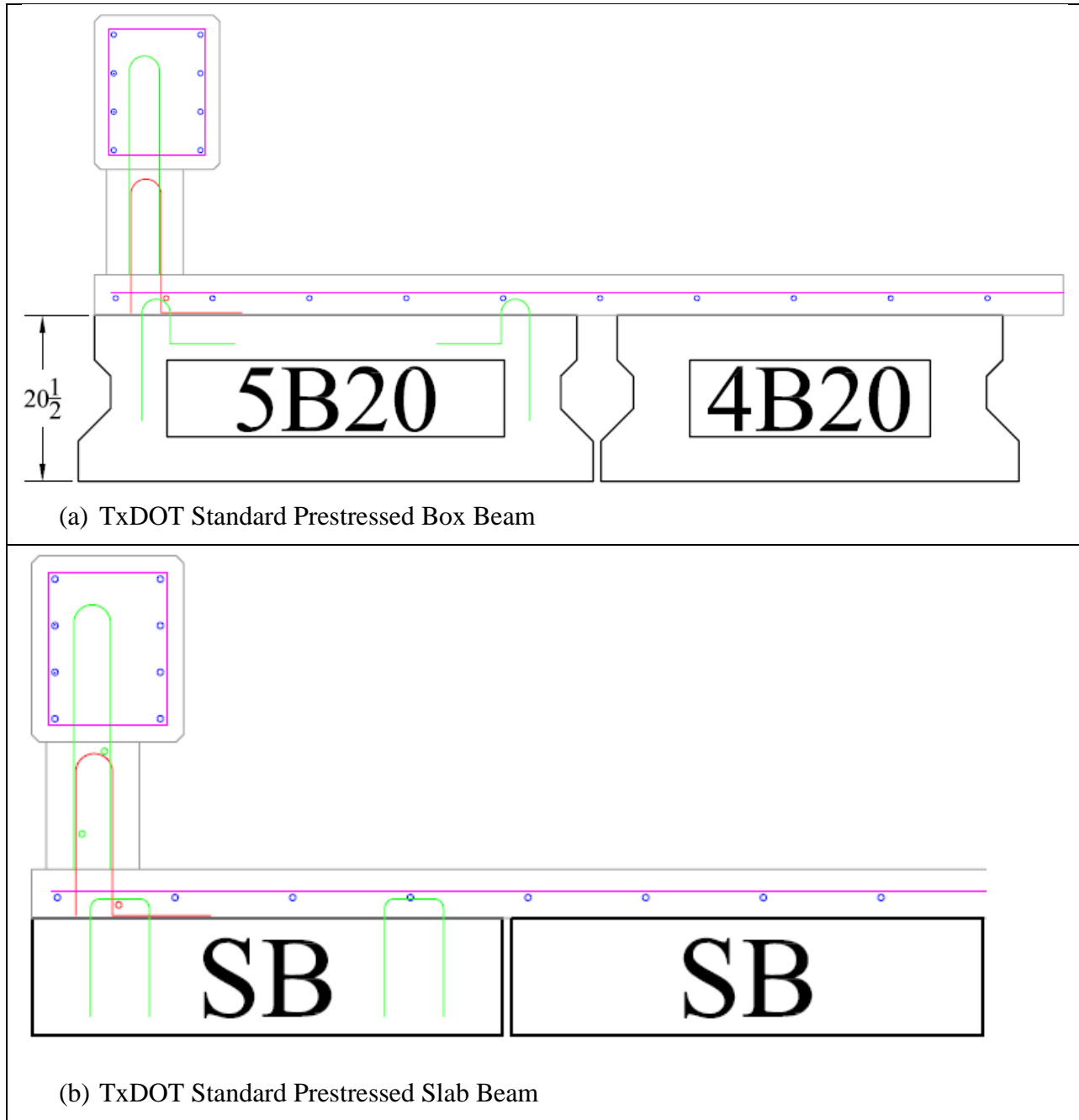

Figure 2.2. Comparison of TxDOT Standard Prestressed Box and Slab Beams.

2.2 T223 BARRIER HISTORY

The current T223 design was developed as a result of crash testing under a previous research project (2). This project included National Cooperative Highway Research Program (NCHRP) *Report 350* testing of the TxDOT T203 bridge rail (3). This test was a repeat of a previous test with one exception. The standard steel reinforcement in the railing was replaced with fiber reinforced polymer (FRP) reinforcement. *NCHRP Report 350* test 3-11 resulted in a failure of the system due to rollover. After evaluation of the failed test, it was concluded that the FRP reinforcement was not the cause of the failure. It was concluded that the 27-inch rail height combined with the rigid nature of the barrier contributed to destabilization of the impacting vehicle resulting in the vehicle rolling over. Subsequently, the barrier was retrofitted with a structural tube section that effectively raised the height of the barrier to 30-inches. The crash test was repeated with successful results according to *NCHRP Report 350*. Subsequently, the concrete beam height was increased to make the total height of the barrier 32-inches while maintaining the 13-inch post height. This permitted the barrier to accommodate a 2-inch pavement overlay. The modified rail became known as the T223.

2.3 T223 ANCHORAGE MODIFICATIONS

The objective of modifying the anchorage details was to minimize changes to current TxDOT standards while providing sufficient capacity to anchor a T223 barrier in a 5-inch deck cast on a standard TxDOT prestressed box beam. Previous research performed under Project 0-5210 (4) demonstrated that #5 “U” bars outperform other tested methods for anchoring rebar in a 4-inch deck without resorting to studs welded to anchor plates. For this reason, the “U” bar anchorage was retained. However, it was relocated to sit directly on the top surface of the precast box beam in order to obtain as much embedment depth as possible in the thin deck.

Second, a #5 bar was added that runs inside of the “Z” bar anchor and over the “U” bar anchor. This added bar helps tie the “Z” bar to the “U” bar to provide more anchorage for the T223 barrier. This added anchorage is meant to replace some of the capacity lost due to the reduced embedment depth.

Third, due to the narrowness of the protruding portion of the “Z” bar, it is not possible for a #5 rebar to be thread through the “Z” bar and still traverse the embedded leg of the “U” bar. For this reason the protruding portion of the “Z” bar was widened, as shown in Figure 2.3.

Finally, a method was needed to spread the load across neighboring barrier segments to reduce the load on the rebar anchors at an expansion joint. This was accomplished using two #8 dowel bars to transfer shear across the joint. One end of the dowel bars was sleeved to create a slip joint that would transfer shear load from one barrier segment to another without restricting longitudinal expansion and contraction. This helps spread the load across more anchorage locations, thereby reducing the load on each anchorage bar.

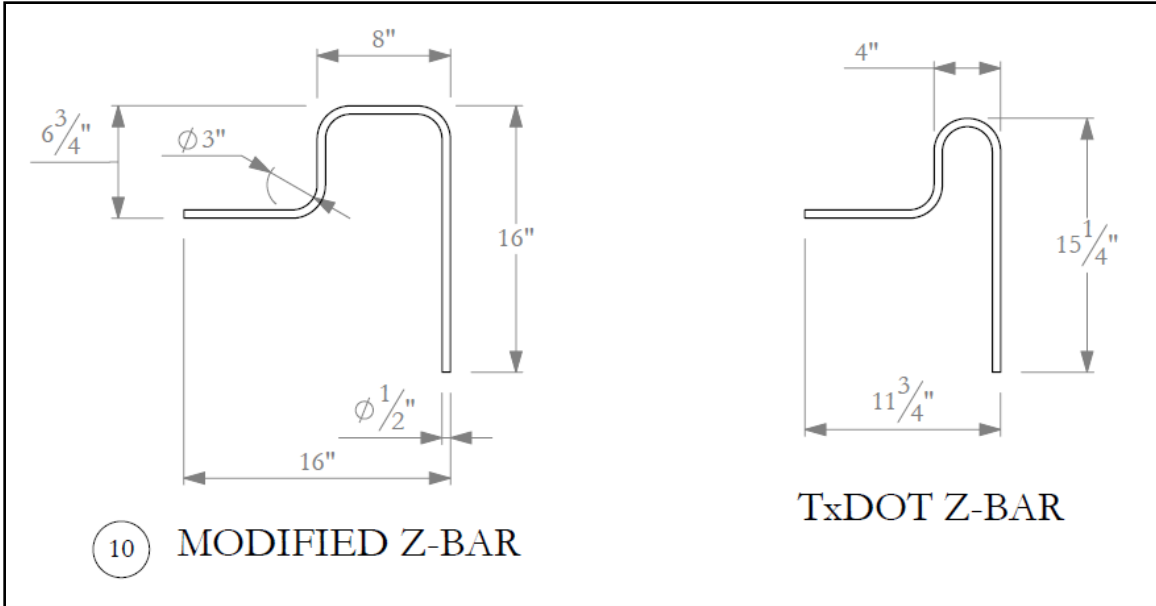

Figure 2.3. Comparison of TxDOT Standard “Z” Bar and Modified “Z” Bar Dimensions.

CHAPTER 3. EVALUATION OF *MASH* TESTING MATRIX

3.1 OBJECTIVES OF TESTING

The objectives of the full-scale crash testing of the T223 barrier with modified anchorage details included:

- 1) Evaluating the impact performance of the T223 barrier according to recently published *MASH* evaluation criteria.
- 2) Evaluating the ability of the new anchorage details to anchor the T223 barrier while preventing costly damage to a 5-inch CIPD during an impact event.

3.2 TEST MATRIX

According to *MASH*, two tests are recommended for evaluating longitudinal barriers to test level three (TL-3). Details of these tests are described below.

3.2.1 *MASH Test 3-10*

Test 3-10 involves an 1100C (2425 lb/1100 kg) vehicle impacting the critical impact point (CIP) of the length of need (LON) of the barrier at a nominal impact speed and angle of 62 mi/h and 25 degrees, respectively. This test investigates occupant risk.

Researchers concluded that this test was not required for the evaluation of the T223 for the following reasons. First, the T223 barrier profile has previously been tested according to *NCHRP Report 350*. This series of tests included an impact of an 1800-lb (820 kg) small passenger vehicle at a speed of 62 mph and an angle of 20 degrees. Additionally, *MASH* test 3-10 was recently performed successfully on a semi-rigid barrier that had an 11-inch opening at the bottom of the barrier with a zero post setback distance (5). Although the clear opening of the T223 is 13 inches, the increase in snagging potential is mitigated by the 4.5-inch post setback distance.

3.2.2 *MASH Test 3-11*

This project evaluated the performance of the rebar anchorage details. It is well understood that the larger 2270P pickup truck used in *MASH* test 3-11 would provide a higher impact load for a better evaluation of the performance of the rebar anchorage details. This test consists of a 2270P (5000 lb/2270 kg) vehicle impacting the CIP of the LON of the barrier at a nominal impact speed and angle of 62 mi/h and 25 degrees, respectively. This is a strength evaluation for test level 3 to verify a barrier's performance for impacts involving light trucks and SUVs. This test was considered to be the most critical for evaluating the modified rebar anchor details.

3.3 DETERMINATION OF CRITICAL IMPACT LOCATION

It was suggested that the vehicle should impact the barrier upstream of an expansion joint to maximize forces in the rebar anchorage. The exact distance upstream of the expansion joint was selected to maximize load on the barrier end. *MASH* Table 2-6 defines the CIP for 1100C and 2270P vehicles for all six test levels when impacting a rigid barrier. This impact point maximizes the load placed on the barrier at the target location. *MASH* Table 2-6 states that for test 3-11, the vehicle should impact the barrier 4.3 ft upstream of the target location.

In this case, the expansion joint between barrier segments was selected as the target location. This location was selected because it represents a discontinuity in both the bridge deck and the bridge rail. This discontinuity represents a worst case for delamination of the deck elements at the anchorage locations. Further, it will concentrate the highest load through the rail anchorages into bridge deck.

CHAPTER 4. SYSTEM DETAILS

4.1 TEST ARTICLE DESIGN AND CONSTRUCTION

The test article was constructed in three phases to represent three primary components:

- 1) The simulated prestressed box beam.
- 2) The 5-inch CIPD.
- 3) The T223 barrier.

Figure 4.1 shows a detailed cross-section of the test article. The installation had a total length of approximately 78 ft. A 1-inch wide expansion joint through the entire section of the test article was placed 24-ft downstream of the upstream end of the installation.

4.2 SIMULATED PRESTRESSED BOX BEAM

It would have been excessively expensive to purchase custom prestressed box beams for the construction of the test installation. Therefore, simulated prestressed box beams with similar geometry and reinforcement were fabricated using TxDOT Class H (5000 psi) concrete.

When forming the surrogate beam, care was taken to match the geometry of the top half of the box beam. The beam was completely free standing. The surrogate beam maintained a minimum thickness of 5.5-inches across the top and 5-inches along the sides to represent the geometry of an actual box beam. A 2-inch wide, 7-inch tall protrusion was formed into the top edge of the field side of the beam to represent geometry found in the box beam. By including these forming details, the surrogate beam section maintained a cross-section that represented the true cross-section of the TxDOT standard prestressed beam. In areas where the sections differed, a conservative approach was taken. In these cases, a thickness less than that of the standard box beam section was maintained. The beam had a 16-inch thick section at each end where all voids were removed from the cross-section to replicate the standard TxDOT box beam detail.

All rebar details followed the TxDOT box beam standard with the exception of the composite anchor bars (Z-bars). Eight #5 bars spaced 6-inches on centers were placed in the top deck along the length of the box beam section. Transverse “A” bars and 49-inch transverse “B” bars were placed in the top deck every 4 inches for the first 48-inches on each end of the beam. The spacing was then increased to 6-inches throughout the rest of the barrier. Modified “Z” bars were spaced every 12 inches along the length of the beam. Each “Z” bar protrudes out of the top of the beam approximately 2¼-inches. Finally, an additional #5 bar was tied inside the interior radius of the protruding modified “Z” bar. This bar was added to improve anchorage of the T223 bridge rail in the thin 5-inch thick cast-in-place bridge deck.

The top deck of the box beam was then finished to provide a uniform rough wood float finish to enhance the bonding of the beam to the 5-inch thick CIPD. A 1-inch wide expansion joint was cast through the entire cross-section of the box beam 24-ft downstream of the upstream end of the installation.

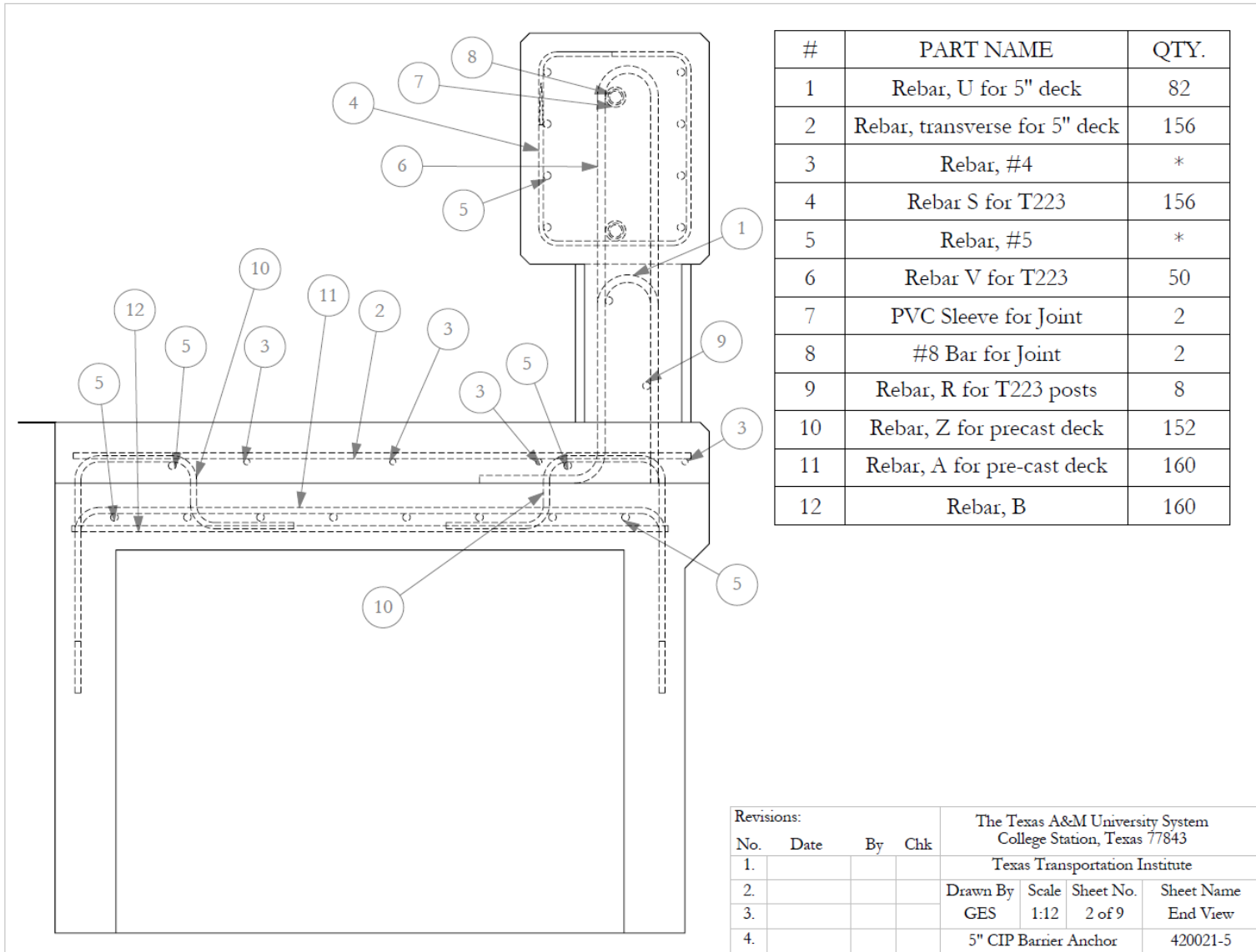

T:\2010-2011\420021\5-5"CIP-Barrier Anchors\SolidWorks\420021-5 Drawing

2011-05-09

Figure 4.1. Test Article Cross-Section.

4.3 5-INCH CAST-IN-PLACE DECK

After casting of the box beam was completed, a 5-inch thick cast-in-place deck (CIPD) was then cast on top of the simulated box beam. Reinforcement of the deck consisted of four #4 bars spaced 12-inches on center along the length of the beam. Transverse #4 bars were spaced every 6-inches along the length of the deck. Each of the transverse bars was welded to existing rebar in an adjacent concrete apron to represent a continuous slab spanning multiple box beams.

At each T223 concrete post location, #5 “U” bar anchors were installed to provide anchorage of the barrier to the 5-inch CIPD. Each U-bar anchor was installed such that it rested directly on the box beam surface and passed under the #5 longitudinal bar attached to the “Z” bar protruding out of the box beam. Each “U” bar was installed with at 4¼-inch clear distance to the back edge of the 5-inch CIPD. In the T223 posts nearest the expansion joint and the ends of the test article, the “U” bars were spaced approximately 3½-inches on center. Should a “U” bar need to be installed at the same location as a protruding “Z” bar, the “U” bar was moved to either side of the “Z” bar while maintaining a 1-inch tolerance to its intended location. At all other post locations, the “U” bars were spaced approximately 6-inches apart.

Before casting the 5-inch CIPD, the surface of the box beam was thoroughly wetted. Subsequently, all remaining puddles of excess water were removed to provide a surface that was moist and saturated before the placement of concrete. Pre-wetting is required by TxDOT construction specifications and previous TxDOT experience has shown this procedure can dramatically improve the bond between the two concrete layers. Again an expansion joint was placed 24-ft downstream of the upstream end of the installation. A TxDOT Class S (4000 psi) concrete was used for the 5-inch CIPD.

4.4 T223 BARRIER

A T223 barrier consists of two main components. The 4-ft long × 9½-inch thick × 13-inch tall intermediate posts support the rail beam and transfer the impact load to the deck. A 15½-inch wide × 19-inch tall concrete beam sits atop the concrete posts. The barrier has a total height of 32 inches measured from the bridge deck surface. The back face is fabricated such that it is flush with the back face of the 5-inch CIPD and box beam. Each intermediate post is inset 4½ inches from the face of the beam to reduce the risk of snagging the wheel of an impacting vehicle.

A 30-inch long #5 “V” bar is placed at each “U” bar anchor location. This allows for an integrated transfer of load from the concrete beam through the intermediate post into the “U” bar anchoring the barrier to the 5-inch CIPD. Two longitudinal #4 bars are installed through each protruding “U” bar inside each intermediate post. A 16-inch tall by 12½-inch wide #3 stirrup was placed in the center of the concrete beam every 6-inches along the entire length of the T223 barrier. Each stirrup was centered inside the concrete beam cross-section. A total of eight #5 longitudinal bars were spaced equally across the traffic and rear faces of the T223 stirrups and extended the full length of each T223 barrier segment. A TxDOT Class C (3600 psi) concrete was used to cast the barrier.

Finally, two 60-inch #8 rebar dowels spanned the expansion joint. The downstream end of each #8 bar was directly embedded into the T223 concrete beam. The upstream ends of the #8 rebars were inserted into 1¼-inch diameter Schedule 80 PVC pipe sleeves. This permitted longitudinal expansion of the bridge and barrier while providing shear resistance across the expansion joint. Further details of the test article can be found in reference 7.

4.5 MATERIAL SPECIFICATIONS

All rebar used to construct the test article met grade 60 specifications. A TxDOT Class S (4000 psi) concrete was used to construct the 5-inch CIPD. The deck concrete had a compressive strength of 3893 psi on the day of the test. A TxDOT Class C (3600 psi) concrete was used to construct the barrier. The barrier concrete had a compressive strength of 3206 psi on the day of the test.

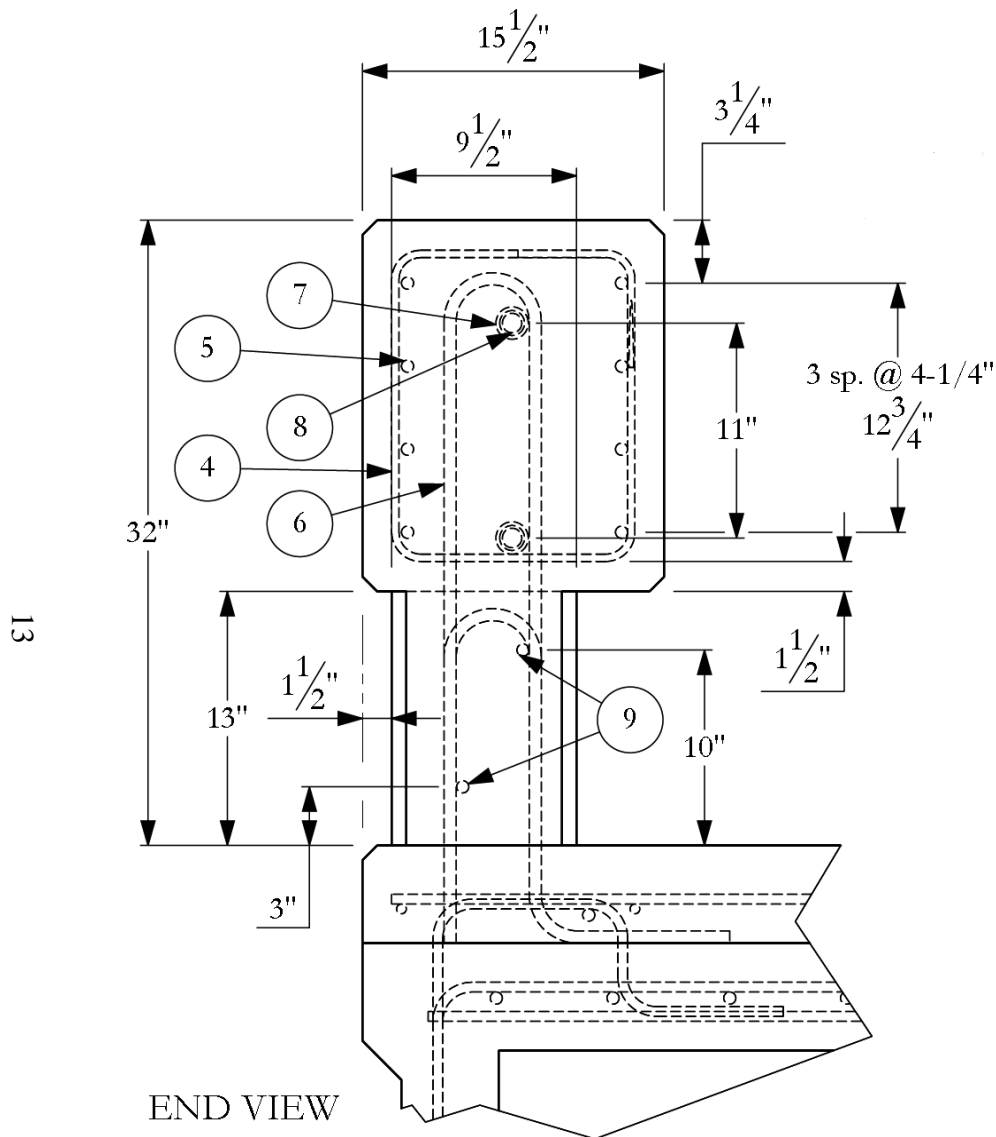

#	PART NAME	QTY.
1	Rebar, U for 5" deck	82
2	Rebar, transverse for 5" deck	156
3	Rebar, #4	*
4	Rebar S for T223	156
5	Rebar, #5	*
6	Rebar V for T223	50
7	PVC Sleeve for Joint	2
8	#8 Bar for Joint	2
9	Rebar, R for T223 posts	8
10	Rebar, Z for precast deck	152
11	Rebar, A for pre-cast deck	160
12	Rebar, B	160

Figure 4.2. Details of the 5-inch CIPD Barrier Anchor Installation.

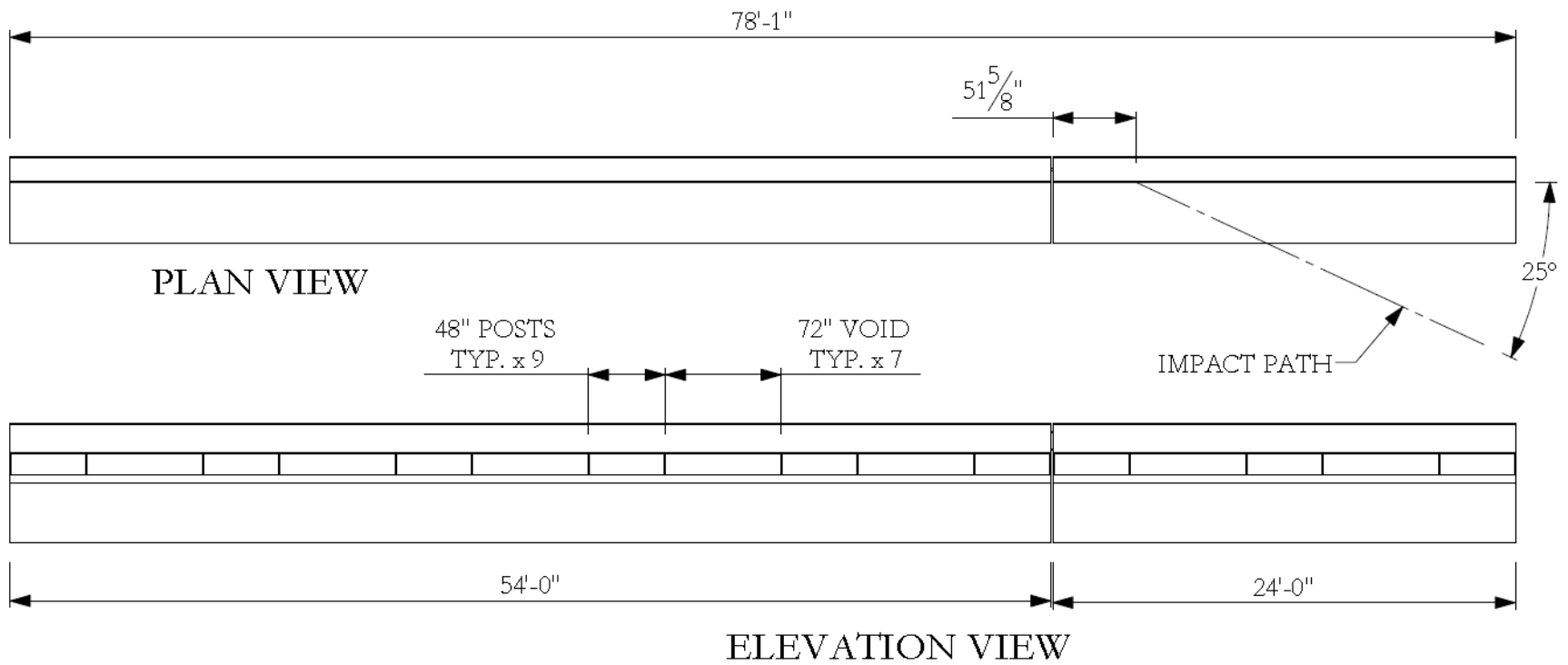

Figure 4.3. Layout of the 5-inch CIPD Barrier Anchor Installation.



Figure 4.4. 5-inch CIPD Barrier Anchor Installation before Test No. 420021-5.

CHAPTER 5. TEST REQUIREMENTS AND EVALUATION CRITERIA

5.1 CRASH TEST CONDITIONS

The test reported herein was *MASH* test 3-11. This test involves a 2270P (5000 lb/2270 kg) vehicle impacting the critical impact point (CIP) of the length of need (LON) of the barrier at a nominal impact speed and angle of 62 mi/h and 25 degrees, respectively. This is a strength test for test levels 1 through 3 to verify a barrier's performance for impacts involving light trucks and SUVs for all test levels. The CIP was determined to be 51.6 inches upstream of the expansion joint.

The crash test and data analysis procedures were in accordance with guidelines presented in *MASH*. Chapter 4 presents brief descriptions of these procedures.

5.2 EVALUATION CRITERIA

The crash test was evaluated in accordance with the criteria presented in *MASH*. The performance of the T223 bridge rail anchored to a 5-inch thick cast-in-place deck (CIPD) was judged on the basis of three factors: structural adequacy, occupant risk, and post impact vehicle trajectory. Structural adequacy is judged upon the ability of the barrier and anchorage system to contain and redirect the vehicle. Occupant risk criteria evaluates the potential risk of hazard to occupants in the impacting vehicle, and to some extent other traffic, pedestrians, or workers in construction zones, if applicable. Post impact vehicle trajectory is assessed to determine potential for secondary impact with other vehicles or fixed objects, creating further risk of injury to occupants of the impacting vehicle and/or risk of injury to occupants in other vehicles. The appropriate safety evaluation criteria from table 5-1 of *MASH* were used to evaluate the crash test reported herein and are listed in further detail under the assessment of the crash test.

CHAPTER 6. CRASH TEST PROCEDURES

6.1 TEST FACILITY

The full-scale crash test reported herein was performed at Texas Transportation Institute (TTI) Proving Ground. TTI Proving Ground is an International Standards Organization (ISO) 17025 accredited laboratory with American Association for Laboratory Accreditation (A2LA) Mechanical Testing certificate 2821.01. The full-scale crash test was performed according to TTI Proving Ground quality procedures and according to the *MASH* guidelines and standards.

The Texas Transportation Institute Proving Ground is a 2000-acre complex of research and training facilities located 10 miles northwest of the main campus of Texas A&M University. The site, formerly an Air Force base, has large expanses of concrete runways and parking aprons well suited for experimental research and testing in the areas of vehicle performance and handling, vehicle-roadway interaction, durability and efficacy of highway pavements, and safety evaluation of roadside safety hardware. The site selected for construction and testing of the T223 bridge rail anchored to a 5-inch thick cast-in-place deck (CIPD) was along the edge of an out-of-service apron. The apron consists of an unreinforced jointed-concrete pavement in 12.5 ft by 15 ft blocks nominally 8 to 12 inches deep. The apron is over 50 years old, and the joints have some displacement, but are otherwise flat and level.

6.2 VEHICLE TOW AND GUIDANCE PROCEDURES

The test vehicle was towed into the test installation using a steel cable guidance and reverse tow system. A steel cable for guiding the test vehicle was tensioned along the path, anchored at each end, and threaded through an attachment to the front wheel of the test vehicle. An additional steel cable was connected to the test vehicle, passed around a pulley near the impact point, through a pulley on the tow vehicle, and then anchored to the ground such that the tow vehicle moved away from the test site. A two-to-one speed ratio between the test and tow vehicle existed with this system. Just prior to impact with the installation, the test vehicle was released to be free-wheeling and unrestrained. The vehicle remained free-wheeling, i.e., no steering or braking inputs, until the vehicle cleared the immediate area of the test site, at which time brakes on the vehicle were activated to bring it to a safe and controlled stop.

6.3 DATA ACQUISITION SYSTEMS

6.3.1 Vehicle Instrumentation and Data Processing

The test vehicle was instrumented with a self-contained, on-board data acquisition system. The signal conditioning and acquisition system is a 16-channel, Tiny Data Acquisition System (TDAS) Pro produced by Diversified Technical Systems, Inc. The accelerometers, that measure the x, y, and z axis of vehicle acceleration, are strain gauge type with linear millivolt output proportional to acceleration. Angular rate sensors, measuring vehicle roll, pitch, and yaw rates, are ultra small size, solid state units designs for crash test service. The TDAS Pro hardware and software conform to the latest SAE J211, Instrumentation for Impact Test. Each of

the 16 channels is capable of providing precision amplification, scaling, and filtering based on transducer specifications and calibrations. During the test, data are recorded from each channel at a rate of 10,000 values per second with a resolution of one part in 65,536. Once recorded, the data are backed up inside the unit by internal batteries should the primary battery cable be severed. Initial contact of the pressure switch on the vehicle bumper provides a time zero mark as well as initiating the recording process. After each test, the data are downloaded from the TDAS Pro unit into a laptop computer at the test site. The raw data are then processed by the Test Risk Assessment Program (TRAP) software to produce detailed reports of the test results. Each of the TDAS Pro units is returned to the factory annually for complete recalibration. Accelerometers and rate transducers are also calibrated annually with traceability to the National Institute for Standards and Technology.

TRAP uses the data from the TDAS Pro to compute occupant/compartiment impact velocities, time of occupant/compartiment impact after vehicle impact, and the highest 10-millisecond (ms) average ridedown acceleration. TRAP calculates change in vehicle velocity at the end of a given impulse period. In addition, maximum average accelerations over 50-ms intervals in each of the three directions are computed. For reporting purposes, the data from the vehicle-mounted accelerometers are filtered with a 60-Hz digital filter, and acceleration versus time curves for the longitudinal, lateral, and vertical directions are plotted using TRAP.

TRAP uses the data from the yaw, pitch, and roll rate transducers to compute angular displacement in degrees at 0.0001-s intervals and then plots yaw, pitch, and roll versus time. These displacements are in reference to the vehicle-fixed coordinate system with the initial position and orientation of the vehicle-fixed coordinate systems being initial impact.

6.3.2 Anthropomorphic Dummy Instrumentation

Use of a dummy in the 2270P vehicle is optional according to *MASH*, and there was no dummy used in the tests with the 2270P vehicle.

6.3.3 Photographic Instrumentation and Data Processing

Photographic coverage of the test included three high-speed cameras: one overhead with a field of view perpendicular to the ground and directly over the impact point; one placed behind the installation at an angle; and a third placed to have a field of view parallel to and aligned with the installation at the downstream end. A flashbulb activated by pressure-sensitive tape switches was positioned on the impacting vehicle to indicate the instant of contact with the installation and was visible from each camera. The films from these high-speed cameras were analyzed on a computer-linked motion analyzer to observe phenomena occurring during the collision and to obtain time-event, displacement, and angular data. A mini-DV camera and still cameras recorded and documented conditions of the test vehicle and installation before and after the test.

CHAPTER 7. CRASH TEST RESULTS

7.1 TEST DESIGNATION AND ACTUAL IMPACT CONDITIONS

MASH test 3-11 involves a 2270P vehicle weighing 5000 lb \pm 100 lb and impacting the test article at an impact speed of 62.2 mi/h \pm 2.5 mi/h and an angle of 25 degrees \pm 1.5 degrees. The target impact point was 51.6 inches upstream of the centerline of the expansion joint nearest post 3. The 2005 Dodge Ram 1500 Quad-Cab used in the test weighed 5004 lb, and the actual impact speed and angle were 62.5 mi/h and 26.5 degrees, respectively. The actual impact point was 54.5 inches upstream of the expansion joint between posts 3 and 4.

7.2 TEST VEHICLE

The 2005 Dodge Ram 1500 Quad-Cab, shown in Figures 7.1 and 7.2, was used for the crash test. Test inertia weight of the vehicle was 5004 lb, and its gross static weight was 5004 lb. The height to the lower edge of the vehicle bumper was 13.5 inches, and the height to the upper edge of the bumper was 29.0 inches. The height to the center of gravity was 28.4 inches. Tables C1 and C2 in Appendix C give additional dimensions and information on the vehicle. The vehicle was directed into the installation using the cable reverse tow and guidance system, and was released to be free-wheeling and unrestrained just prior to impact.

7.3 WEATHER CONDITIONS

The test was performed on the morning of June 23, 2011. A total of 3.2 inches of rainfall was recorded the day before the test, with no other rainfall for 10 days prior that that. Weather conditions at the time of testing were as follows: Wind speed: 4 mi/h; Wind direction: 163 degrees with respect to the vehicle (vehicle was traveling in a southwesterly direction); Temperature: 84°F, Relative humidity: 72 percent.

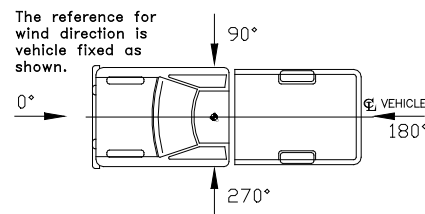

7.4 TEST DESCRIPTION

The 2005 Dodge Ram 1500 Quad-Cab pickup truck, travelling at an impact speed of 62.5 mi/h, impacted the TxDOT T223 bridge rail anchored to a 5-inch thick cast-in-place deck 54.5 inches upstream of the expansion joint between posts 3 and 4 at an impact angle of 26.3 degrees. At 0.022 s after impact, the 2270P vehicle began to redirect. The left front wheel steered abruptly clockwise at 0.035 s, and the right front passenger door contacted the barrier at 0.044 s. At 0.187 s, the vehicle was traveling parallel with the barrier at a speed of 50.7 mi/h. The rear bumper contacted the barrier at 0.203 s. At 0.356 s, the vehicle lost contact with the barrier at an exit speed and exit angle of 49.1 mi/h and 9.4 degrees, respectively. Brakes on the vehicle were applied 5.0 s after impact, and the vehicle came to rest 225 ft downstream of impact and 7.0 ft toward traffic lanes. Figures D1 and D2 in Appendix D show sequential photographs of the test period.



Figure 7.1. Vehicle/Installation Geometrics for Test No. 420021-5.



Figure 7.2. Vehicle before Test No. 420021-5.

7.5 DAMAGE TO TEST INSTALLATION

Figure 7.3 and 7.4 show damage to the TxDOT T223 bridge rail anchored to a 5-inch thick (CIPD). Damage to the barrier was cosmetic in nature with only tire marks and a few gouges observed in the concrete traffic face of the upper beam of the barrier. A few tire scuff marks were noted on the face of posts 3 and 4. No cracks were noted in the beam, posts, or bridge deck. Total length of contact of the vehicle with the barrier was 12.9 ft. The vehicle crossed the exit box 82 ft downstream of impact (≥ 32.8 ft allowed). Working width was 16.0 inches, and maximum deflection of the barrier was 0.9 inch.

7.6 VEHICLE DAMAGE

The 2270P vehicle sustained structural damage to the right frame rail, right upper and lower A-arm, right side sway bar, and right front spring and cup. The right upper ball joint pulled out of the socket and the right lower ball joint broke. Figure 7.5 shows damage to the front bumper, right front fender, right front door, right front tire and wheel rim, right rear door, right rear exterior bed, right rear tire and wheel rim, and the rear bumper. Maximum exterior crush to the 2270P vehicle was 18.0 inches in the side plane at the right front corner at bumper height. Maximum occupant compartment deformation was 5.25 inches in the kick panel laterally across the lower cab near the right front passenger side foot well area. Figure 7.6 shows photographs of the interior of the vehicle. Tables C3 and C4 in Appendix D provide exterior crush and occupant compartment deformation measurements.

7.7 OCCUPANT RISK FACTORS

Data from the accelerometer, located at the vehicle center of gravity, were digitized for evaluation of occupant risk. In the longitudinal direction, the occupant impact velocity was 19.7 ft/s at 0.098 s, the highest 0.010-s occupant ridedown acceleration was 5.6 Gs from 0.207 to 0.217 s, and the maximum 0.050-s average acceleration was -9.2 Gs between 0.032 and 0.082 s. In the lateral direction, the occupant impact velocity was 26.6 ft/s at 0.098 s, the highest 0.010-s occupant ridedown acceleration was 7.2 Gs from 0.239 to 0.249 s, and the maximum 0.050-s average was -13.0 Gs between 0.041 and 0.081 s. Theoretical Head Impact Velocity (THIV) was 36.8 km/h or 10.2 m/s at 0.095 s; Post-Impact Head Decelerations (PHD) was 8.4 Gs between 0.210 and 0.220 s; and Acceleration Severity Index (ASI) was 1.62 between 0.033 and 0.083 s. Figure 7.7 summarizes these data and other pertinent information from the test. Vehicle angular displacements and accelerations versus time traces are presented in Appendix E, Figures E1 through D7.



Figure 7.3. After Impact Vehicle/Barrier Positions for Test No. 420021-5.



Figure 7.4. Installation after Test No. 420021-5.



Figure 7.5. Vehicle after Test No. 420021-5.



Figure 7.6. Interior of Vehicle for Test No. 420021-5.

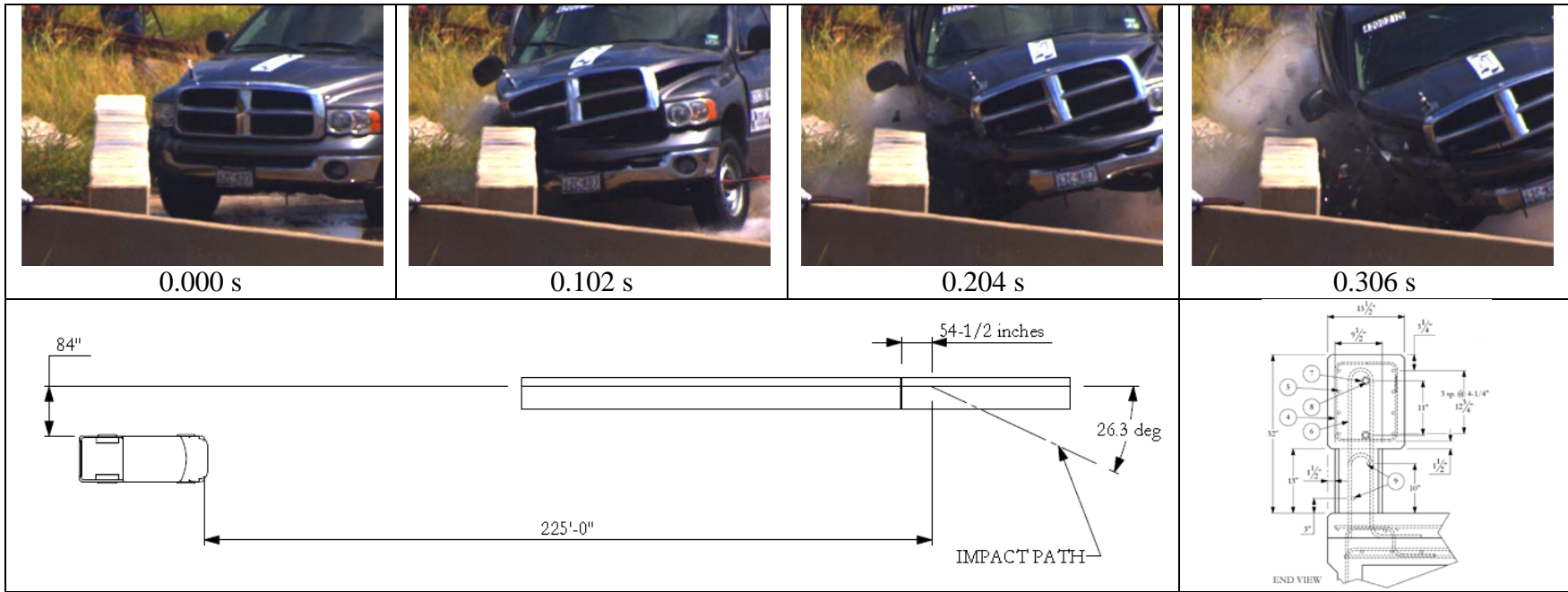

General Information

Test Agency Texas Transportation Institute (TTI)
 Test Standard Test No. MASH Test 3-11
 TTI Test No. 420021-5
 Test Date 2011-06-23

Test Article

Type Barrier Anchors
 Name TxDOT 5-inch CIPD barrier anchors
 Installation Length 78 ft 1 inch
 Material or Key Elements T223 Concrete Parapet on 5-inch Deck

Soil Type and Condition

..... 5-inch Bridge Deck, Dry

Test Vehicle

Type/Designation 2270P
 Make and Model 2005 Dodge Ram 1500 Pickup
 Curb 4668 lb
 Test Inertial 5004 lb
 Dummy No dummy
 Gross Static 5004 lb

Impact Conditions

Speed 62.5 mi/h
 Angle 26.3 degrees
 Location/Orientation 54.5 inches

Exit Conditions

Location/Orientation upstrm of joint
 Speed 49.1 mi/h
 Angle 9.4 degrees

Occupant Risk Values

Impact Velocity
 Longitudinal 19.7 ft/s
 Lateral 26.6 ft/s
 Ridedown Accelerations
 Longitudinal 5.6 G
 Lateral 7.2 G
 THIV 36.8 km/h
 PHD 8.4 G
 ASI 1.62
 Max. 0.050-s Average
 Longitudinal -9.2 g
 Lateral -13.0 G
 Vertical -3.9 G

Post-Impact Trajectory

Stopping Distance 225 ft dwnstrm
 7 ft twd traffic

Vehicle Stability

Maximum Yaw Angle -52 degrees
 Maximum Pitch Angle -5 degrees
 Maximum Roll Angle 20 degrees
 Vehicle Snagging No
 Vehicle Pocketing No

Test Article Deflections

Dynamic 0.9 inch
 Permanent None
 Working Width 16.0 inches

Vehicle Damage

VDS 01RFQ5
 CDC 01FREW4
 Max. Exterior Deformation 18.0 inches
 OCDI RF0010000
 Max. Occupant Compartment
 Deformation 5.25 inches

Figure 7.7. Summary of Results for MASH Test 3-11 on the TxDOT 5-inch CIP Barrier Anchor Installation.

CHAPTER 8. SUMMARY AND CONCLUSIONS

8.1 ASSESSMENT OF TEST RESULTS

An assessment of the test based on the applicable safety evaluation criteria for *MASH* test 3-11 is provided below.

8.1.1 Structural Adequacy

- A. *Test article should contain and redirect the vehicle or bring the vehicle to a controlled stop; the vehicle should not penetrate, underride, or override the installation although controlled lateral deflection of the test article is acceptable.*

Results: The TxDOT T223 bridge rail anchored to a 5-inch thick CIPD contained and redirected the 2270P vehicle. The vehicle did not penetrate, underride, or override the installation. Maximum dynamic deflection of the barrier during the test was 0.9 inch. (PASS)

8.1.2 Occupant Risk

- D. *Detached elements, fragments, or other debris from the test article should not penetrate or show potential for penetrating the occupant compartment, or present an undue hazard to other traffic, pedestrians, or personnel in a work zone.*

Deformation of, or intrusions into, the occupant compartment should not exceed limits set forth in Section 5.3 and Appendix E of MASH (roof ≤ 4.0 inches; windshield = ≤ 3.0 inches; side windows = no shattering by test article structural member; wheel/foot well/toe pan ≤ 9.0 inches; forward of A-pillar ≤ 12.0 inches; front side door area above seat ≤ 9.0 inches; front side door below seat ≤ 12.0 inches; floor pan/transmission tunnel area ≤ 12 inches).

Results: No detached elements, fragments, or other debris were present to penetrate or to show potential for penetrating the occupant compartment, or to present hazard to others in the area. (PASS)
Maximum occupant compartment deformation was 5.25 inches in the kick panel laterally across the lower cab near the right front passenger side foot well area. (PASS)

- F. *The vehicle should remain upright during and after collision. The maximum roll and pitch angles are not to exceed 75 degrees.*

Results: The 2270P vehicle remained upright during and after the collision event. Maximum roll and pitch angles were 20 degrees and -5 degrees, respectively. (PASS)

H. Occupant impact velocities should satisfy the following:

Longitudinal and Lateral Occupant Impact Velocity

<u>Preferred</u>	<u>Maximum</u>
30 ft/s	40 ft/s

Results: Longitudinal occupant impact velocity was 19.7 ft/s, and lateral occupant impact velocity was 26.6 ft/s. (PASS)

I. Occupant ridedown accelerations should satisfy the following:

Longitudinal and Lateral Occupant Ridedown Accelerations

<u>Preferred</u>	<u>Maximum</u>
15.0 Gs	20.49 Gs

Results: Maximum longitudinal occupant ridedown acceleration was 5.6 G, and lateral occupant ridedown acceleration was -7.2 G. (PASS)

8.1.3 Vehicle Trajectory

For redirective devices, the vehicle shall exit the barrier within the exit box (not less than 32.8 ft).

Result: The 2270P vehicle crossed the exit box 82 ft downstream of impact. (PASS)

8.2 CONCLUSIONS

The TxDOT T223 barrier anchored in a 5-inch CIPD on a simulated TxDOT prestressed box beam performed acceptably for *MASH* test 3-11, as shown in Table 8.1. No structural damage to the T223 or 5-inch CIPD was observed after the test. The modified anchorage details provided sufficient capacity to contain and redirect the impacting vehicle without causing any damage to the 5-inch CIPD.

Table 8.1. Performance Evaluation Summary for MASH Test 3-11 on the TxDOT 5-inch CIPD Barrier Anchor Installation.

Test Agency: Texas Transportation Institute

Test No.: 420021-5

Test Date: 2011-06-23

MASH Test 3-11 Evaluation Criteria	Test Results	Assessment
<p>Structural Adequacy</p> <p>A. <i>Test article should contain and redirect the vehicle or bring the vehicle to a controlled stop; the vehicle should not penetrate, underride, or override the installation although controlled lateral deflection of the test article is acceptable.</i></p>	<p>The TxDOT T223 bridge rail anchored to a 5-inch thick CIPD contained and redirected the 2270P vehicle. The vehicle did not penetrate, underride, or override the installation. Maximum dynamic deflection of the barrier during the test was 0.9 inch.</p>	<p>Pass</p>
<p>Occupant Risk</p> <p>D. <i>Detached elements, fragments, or other debris from the test article should not penetrate or show potential for penetrating the occupant compartment, or present an undue hazard to other traffic, pedestrians, or personnel in a work zone. Deformations of, or intrusions into, the occupant compartment should not exceed limits set forth in Section 5.3 and Appendix E of MASH.</i></p>	<p>No detached elements, fragments, or other debris were present to penetrate or to show potential for penetrating the occupant compartment, or to present hazard to others in the area. Maximum occupant compartment deformation was 5.25 inches in the kick panel laterally across the lower cab near the right front passenger side foot well area.</p>	<p>Pass</p>
<p>F. <i>The vehicle should remain upright during and after collision. The maximum roll and pitch angles are not to exceed 75 degrees.</i></p>	<p>The 2270P vehicle remained upright during and after the collision event. Maximum roll and pitch angles were 20 degrees and -5 degrees, respectively.</p>	<p>Pass</p>
<p>H. <i>Longitudinal and lateral occupant impact velocities should fall below the preferred value of 30 ft/s, or at least below the maximum allowable value of 40 ft/s.</i></p>	<p>Longitudinal occupant impact velocity was 19.7 ft/s, and lateral occupant impact velocity was 26.6 ft/s.</p>	<p>Pass</p>
<p>I. <i>Longitudinal and lateral occupant ridedown accelerations should fall below the preferred value of 15.0 Gs, or at least below the maximum allowable value of 20.49 Gs.</i></p>	<p>Maximum longitudinal occupant ridedown acceleration was 5.6 G, and lateral occupant ridedown acceleration was -7.2 G.</p>	<p>Pass</p>
<p>Vehicle Trajectory</p> <p><i>For redirective devices, the vehicle shall exit the barrier within the exit box (not less than 32.8 ft).</i></p>	<p>The 2270P vehicle crossed the exit box line 82 ft downstream of impact.</p>	<p>Pass</p>

CHAPTER 9. IMPLEMENTATION STATEMENT

The TxDOT T223 bridge rail attached to a 5-inch cast-in-place deck (CIPD) performed acceptably for *MASH* test-3-11. There was no structural damage to the CIPD or the T223 bridge rail, and no repairs of the rail would have been required after this design impact event. The anchorage details are recommended for implementation whenever it is desired to attach a concrete rail to a 5-inch CIPD. Implementation can be accomplished through revision of bridge rail standard detail sheets.

The T223 barrier evaluated in the test represents a worst case anchorage condition among the concrete railings used by TxDOT. Consequently, a similar anchorage detail could be used for continuous barrier profiles such as the F-shape and single slope barriers, and metal rails attached to concrete parapets such as the T1F, T1W, and T401.

The #8 rebar spanning the expansion joint did not appear to develop significant load during the impact event. It might be possible to pass the *MASH* test 3-11 without the #8 bars. Further evaluation and testing would need to be performed to fully evaluate this modification.

REFERENCES

1. AASHTO, *Manual for Assessing Safety Hardware*, American Association of State Highway and Transportation Officials, Washington, D.C., 2009.
2. C. E. Buth, W. F. Williams, R. P. Bligh, W. L. Menges, and R. R. Haug, “Performance of the TxDOT T202 (MOD) Bridge Rail Reinforced with Fiber Reinforced Polymer Bars,” Report 0-4138-3. Texas Transportation Institute, College Station, TX, November 2003.
3. H. E. Ross, Jr., D. L. Sicking, R. A. Zimmer and J. D. Michie. *Recommended Procedures for the Safety Performance Evaluation of Highway Features*, National Cooperative Highway Research Program *Report 350*, Transportation Research Board, National Research Council, Washington, D.C., 1993.
4. D.R. Arrington, R. P. Bligh, and W. L. Menges. *Bogie Testing of Shallow Embedded Anchors*. Texas Transportation Institute, College Station, TX, 2010.
5. D. R. Arrington, R. P. Bligh, and W. L. Menges, *MASH Test 3-11 on the 5-inch CIP Barrier Anchors*, Test Report 9-1002-7. Texas Transportation Institute, College Station, TX, August 2011.

APPENDIX A. DETAILS OF THE TXDOT 5-INCH CIP BARRIER ANCHOR INSTALLATION

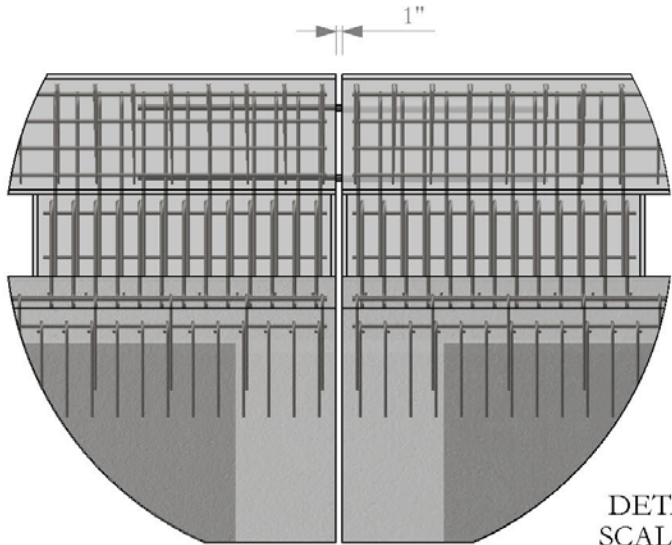
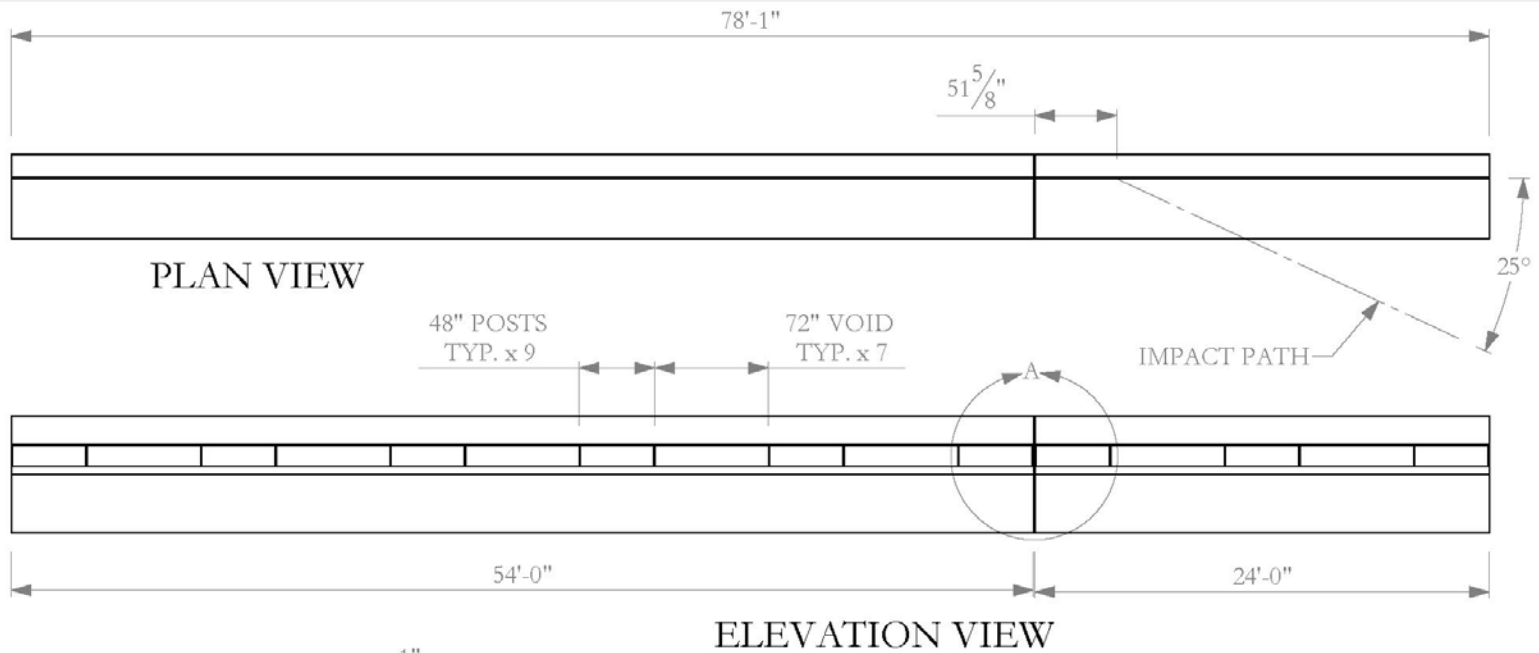

DETAIL A
SCALE 1 : 25

- 1a. All rebar is grade 60.
- 1b. Concrete strength: Box Beam - Class H (5000 psi)
5" Deck - Class S (4000 psi)
T223 Parapet - Class C (3600 psi)
- 1c. Thoroughly wet all forms, prestressed concrete panels, T-beams, and concrete box beams on which concrete is to be placed before placing concrete. Remove any remaining puddles of excess water before placing concrete. Provide surfaces that are in a moist, saturated surface-dry condition when concrete is placed on them.

Revisions:				The Texas A&M University System College Station, Texas 77843			
No.	Date	By	Chk	Texas Transportation Institute			
1.				Drawn By	Scale	Sheet No.	Sheet Name
2.				GES	1:100	1 of 9	Test Installation
3.				5" CIP Barrier Anchor			420021-5
4.				Approved			Date
Dusty Arrington:				Signature			2011-05-09

I:\2010-2011\420021\5 5" CIP Barrier Anchors\SolidWorks\420021-5 Drawing

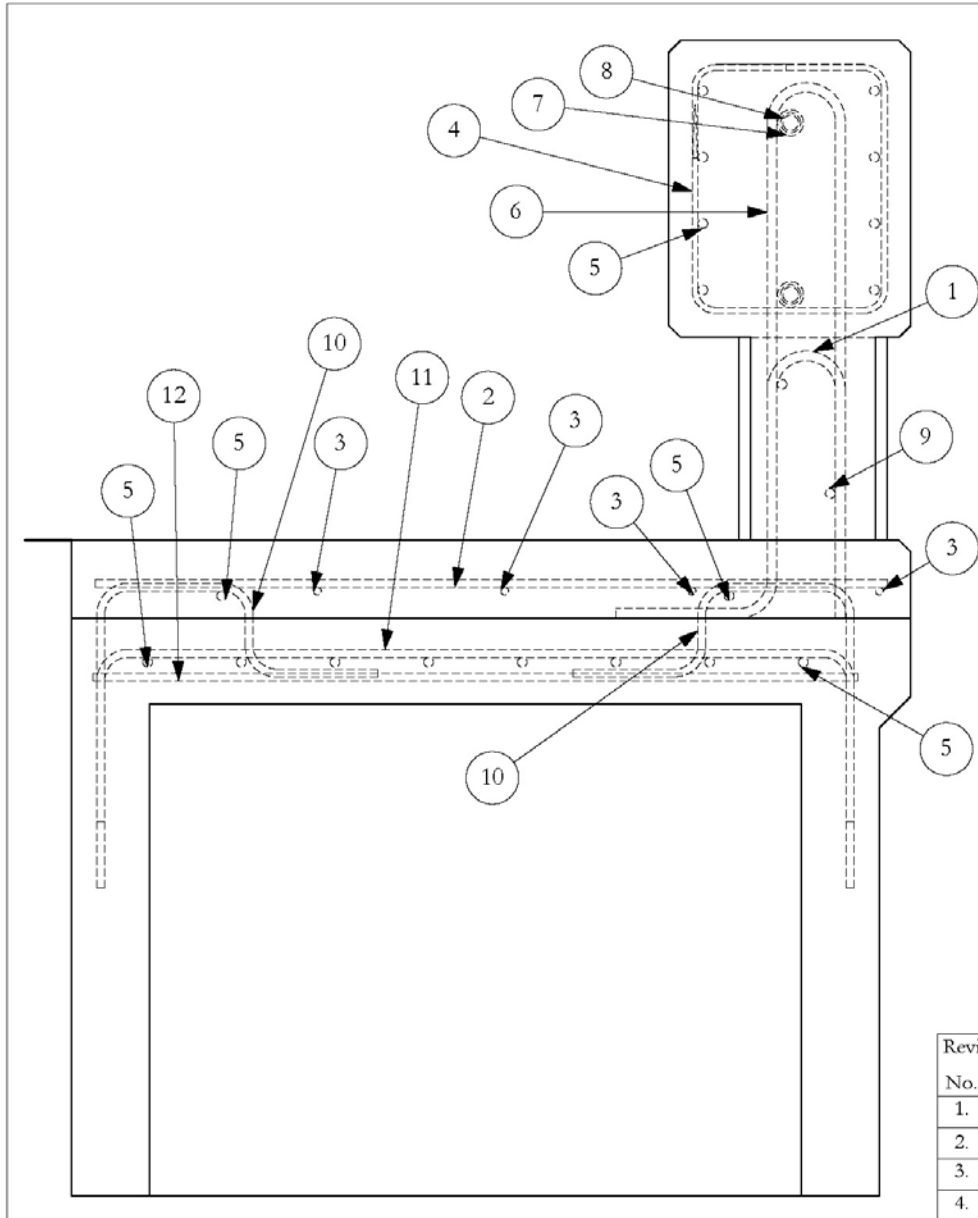

#	PART NAME	QTY.
1	Rebar, U for 5" deck	82
2	Rebar, transverse for 5" deck	156
3	Rebar, #4	*
4	Rebar S for T223	156
5	Rebar, #5	*
6	Rebar V for T223	50
7	PVC Sleeve for Joint	2
8	#8 Bar for Joint	2
9	Rebar, R for T223 posts	8
10	Rebar, Z for precast deck	152
11	Rebar, A for pre-cast deck	160
12	Rebar, B	160

Revisions:				The Texas A&M University System College Station, Texas 77843			
No.	Date	By	Chk	Texas Transportation Institute			
1.				Drawn By	Scale	Sheet No.	Sheet Name
2.				GES	1:12	2 of 9	End View
3.				5" CIP Barrier Anchor			420021-5
4.							

T:\2010-2011\420021\5 5"-CIP-Barrier Anchors\SolidWorks\420021-5 Drawing

BOX BEAM DETAILS

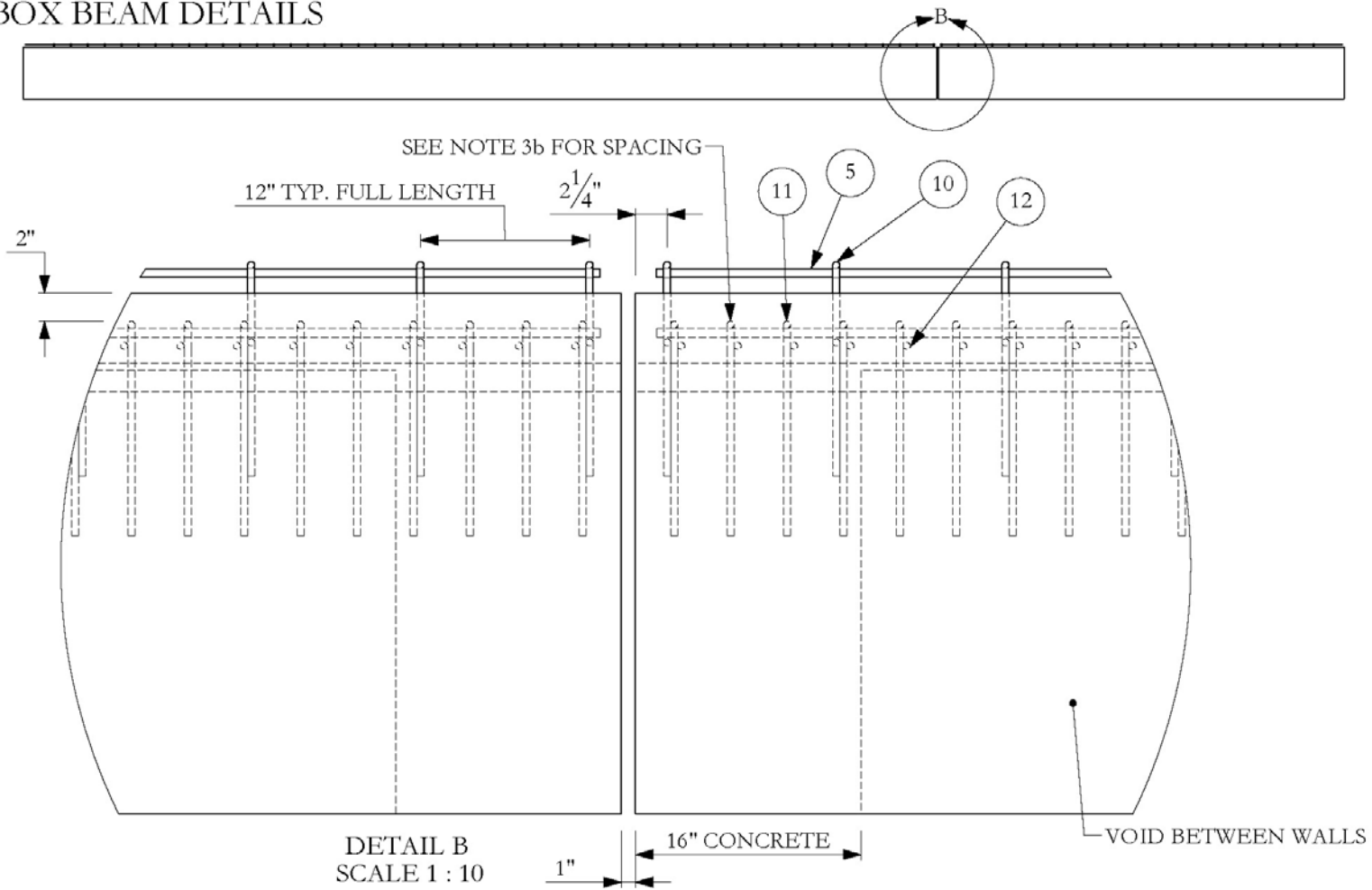

- 3a. Concrete is Class H.
- 3b. Spacing for Bar A (11) and Bar B (12) is 4" for 48" (12 spaces) each side of the expansion joint, then 6" to each end.
- 3c. Lap for #5 bars is 26", and not permissible within 10' of expansion joint.
- 3d. Rebar and concrete is symmetrical from expansion joint to end of short section.
- 3e. Provide a uniform rough wood float finish for the top surface of the concrete.

Revisions:				The Texas A&M University System College Station, Texas 77843			
No.	Date	By	Chk	Texas Transportation Institute			
1.				Drawn By	Scale	Sheet No.	Sheet Name
2.				GES	1:100	3 of 9	Box Beam a
3.				5" CIP Barrier Anchor			420021-5
4.							

T:\2010-2011\420021\5 5"-CIP-Barrier Anchors\SolidWorks\420021-5 Drawing

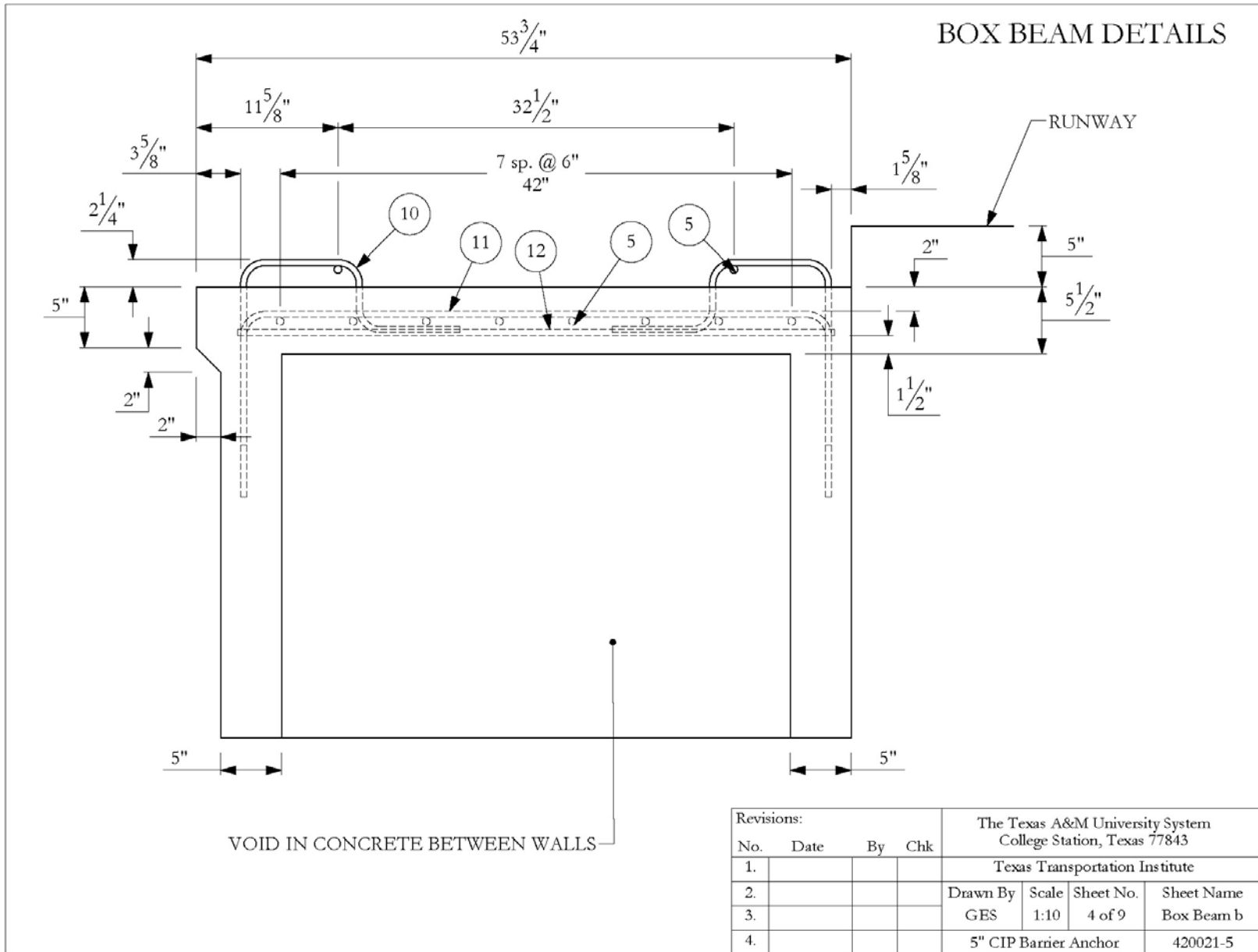

Revisions:				The Texas A&M University System College Station, Texas 77843			
No.	Date	By	Chk	Texas Transportation Institute			
1.				Drawn By	Scale	Sheet No.	Sheet Name
2.				GES	1:10	4 of 9	Box Beam b
3.				5" CIP Barrier Anchor			420021-5
4.							

T:\2010-2011\420021-5-5"-CIP-Barrier Anchors\SolidWorks\420021-5 Drawing

5" SLAB DETAILS

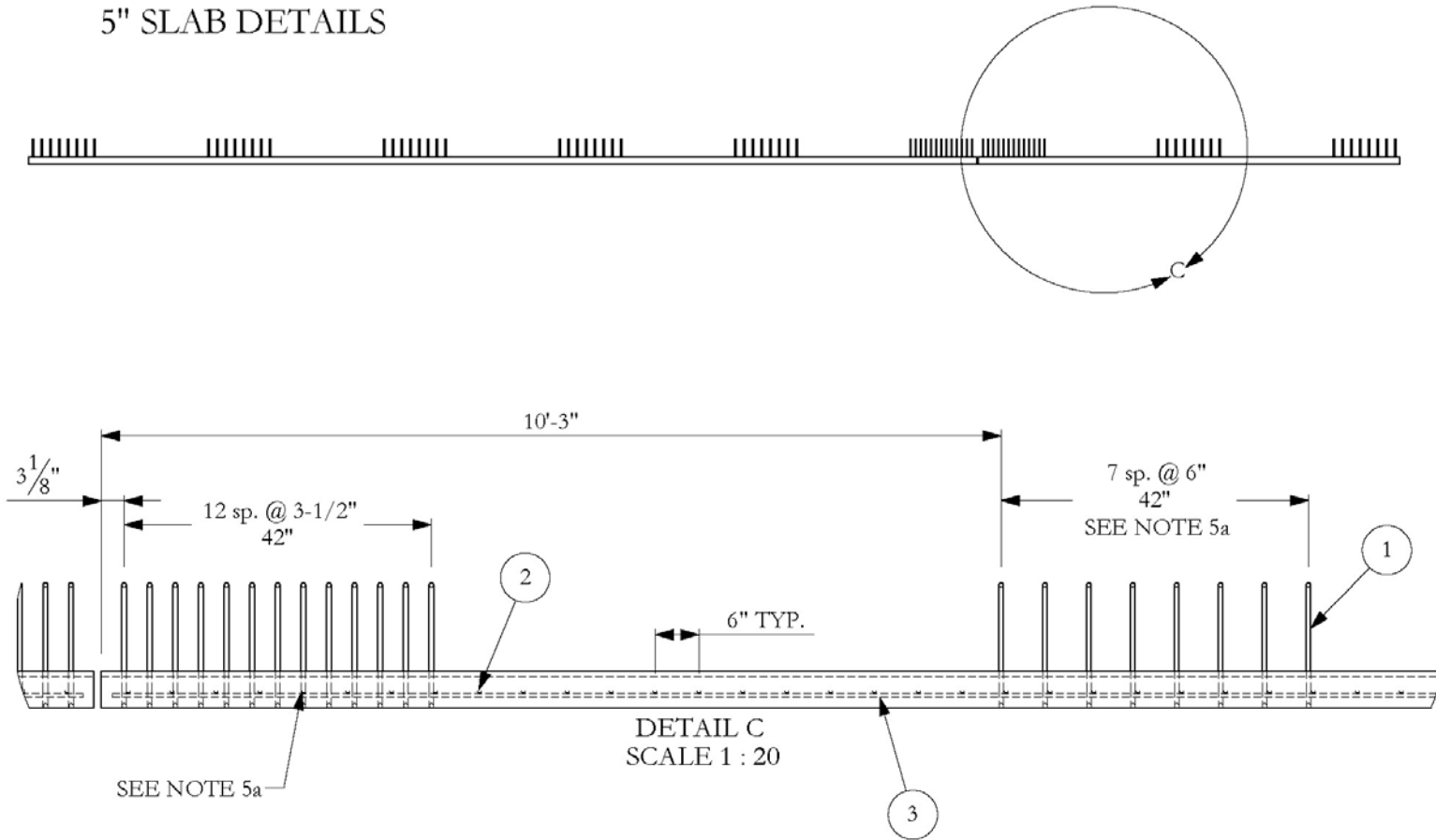

- 5a. U-bar (1) spacing is 3-1/2" at the first post on each side of the expansion joint, U-bar spacing at all other posts is 6". Adjust spacing of transverse bars (2) where necessary to maintain U-bar spacing.
- 5b. Rebar is symmetrical from expansion joint to end of short section.
- 5c. Concrete strength is 4000 psi.
- 5d. Lap for #4 bars is 17", and not permissible within 10' of expansion joint.

Revisions:				The Texas A&M University System College Station, Texas 77843			
No.	Date	By	Chk	Texas Transportation Institute			
1.				Drawn By	Scale	Sheet No.	Sheet Name
2.				GES	1:100	5 of 9	5" Deck a
3.				5" CIP Barrier Anchor			420021-5
4.							

2011-05-09

T:\2010-2011\420021-5 5" CIP Barrier Anchors\SolidWorks\420021-5 Drawing

5" SLAB DETAILS

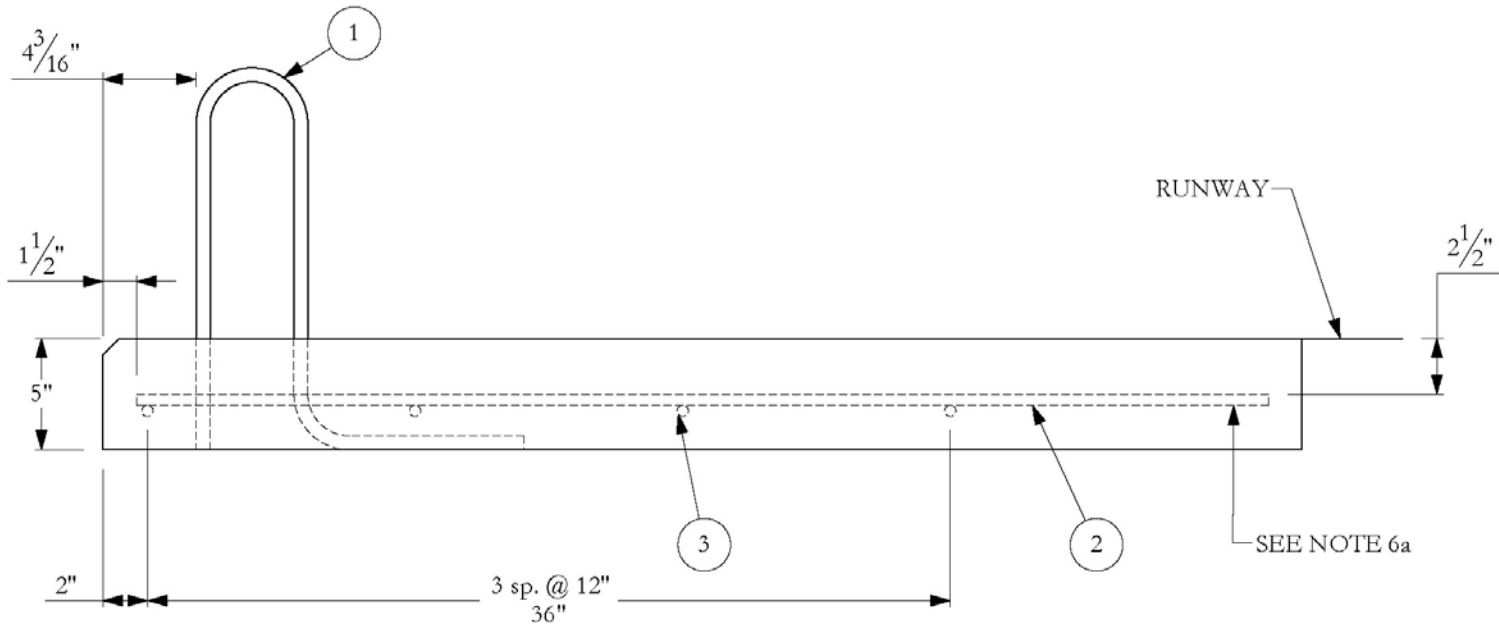

- 6a. Transverse bars (2) weld to existing rebar or strap (not shown) protruding from runway.
- 6b. 3/4" chamfer exposed edge of deck.

Revisions:				The Texas A&M University System College Station, Texas 77843			
No.	Date	By	Chk	Texas Transportation Institute			
1.				Drawn By	Scale	Sheet No.	Sheet Name
2.				GES	1:7	6 of 9	5" Deck b
3.				5" CIP Barrier Anchor			420021-5
4.							

2011-05-09

T:\2010-2011\420021\5"-CIP-Barrier Anchors\SolidWorks\420021-5 Drawing

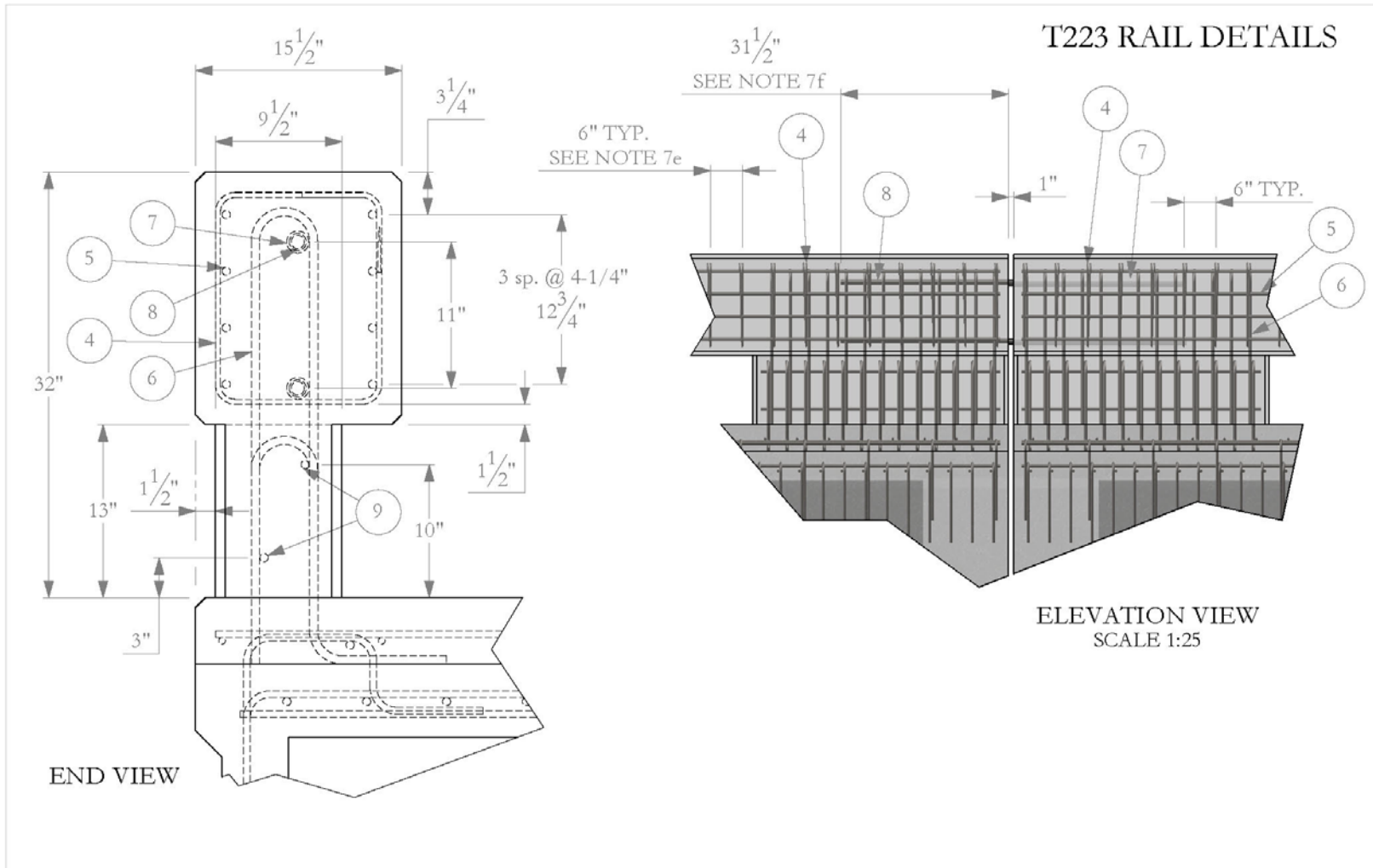

- 7a. 3/4" chamfer all exposed edges of parapet (some chamfers not shown here).
- 7b. Concrete is Class C.
- 7c. Lap for #5 bars is 26", and not permissible within 10' of expansion joint.
- 7d. Spacing on V-bars (6) is same as U-bars (1) (see Note 5a).
- 7e. Adjust spacing of S-bars (4) as necessary to maintain spacing of V-bars.
- 7f. Embedment depth of Ø1" rod (8) in concrete.

Revisions:				The Texas A&M University System College Station, Texas 77843			
No.	Date	By	Chk	Texas Transportation Institute			
1.				Drawn By	Scale	Sheet No.	Sheet Name
2.				GES	1:10	7 of 9	T223 Rail
3.				5" CIP Barrier Anchor			420021-5
4.							

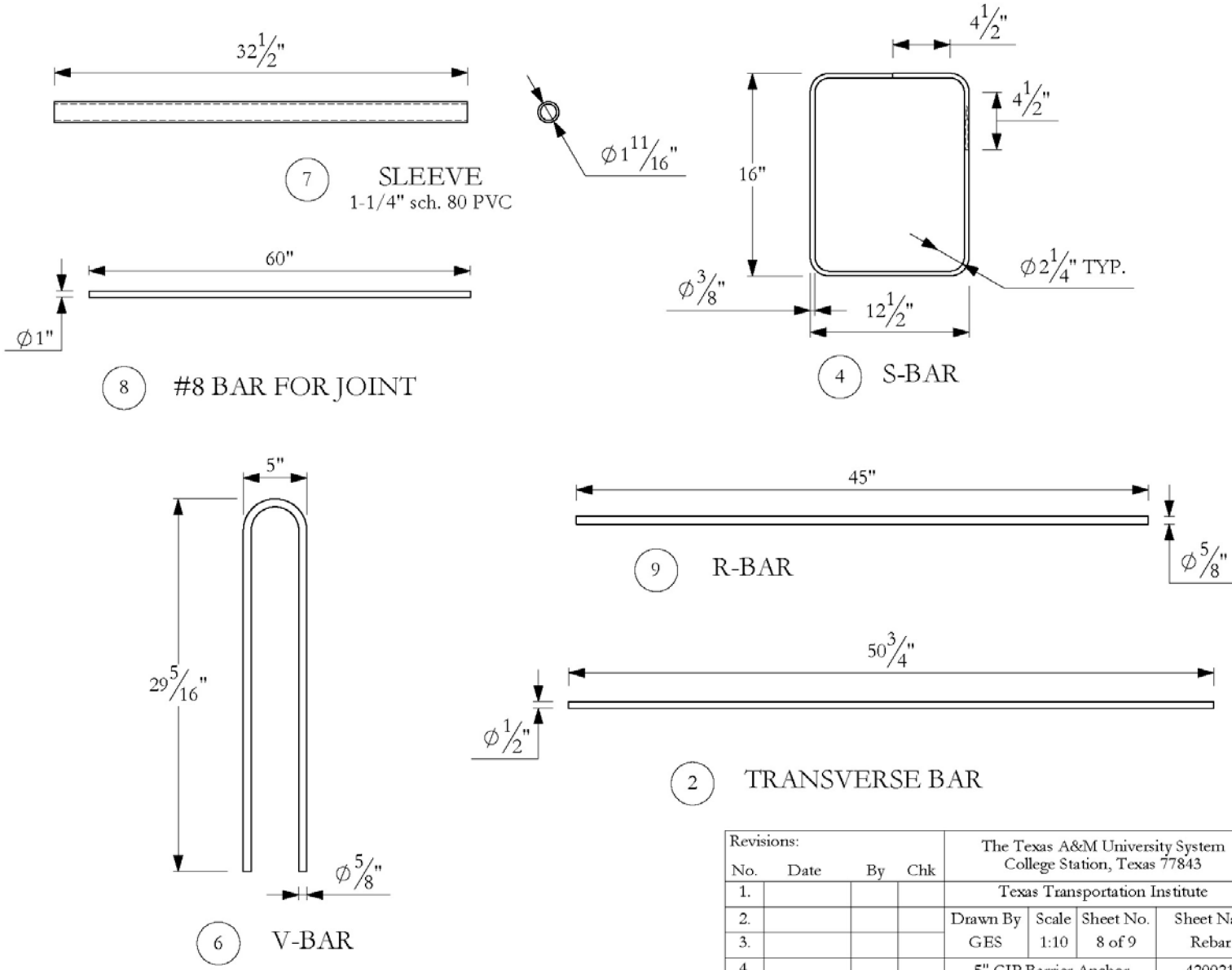

Revisions:				The Texas A&M University System College Station, Texas 77843			
No.	Date	By	Chk	Texas Transportation Institute			
1.				Drawn By	Scale	Sheet No.	Sheet Name
2.				GES	1:10	8 of 9	Rebar a
3.				5" CIP Barrier Anchor			420021-5
4.							

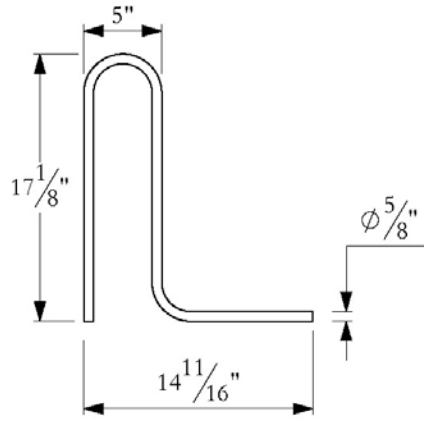

1 U-BAR

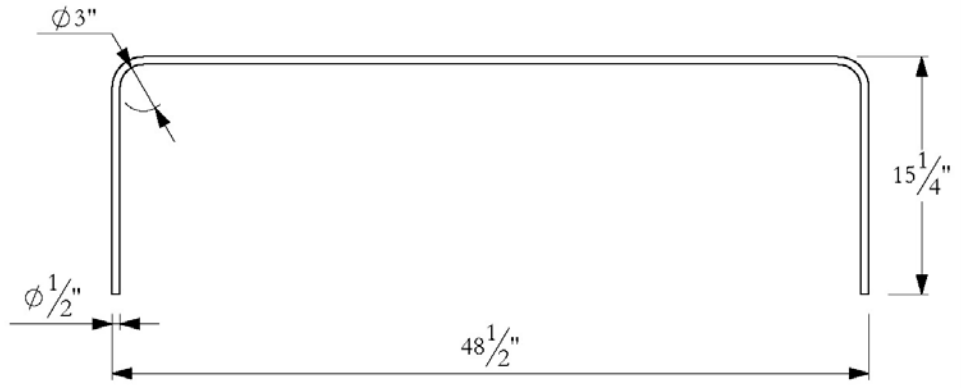

11 A-BAR
SEE NOTE 9a

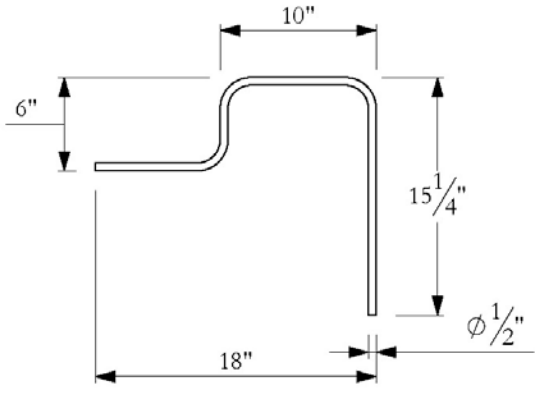

10 Z-BAR
SEE NOTE 9a

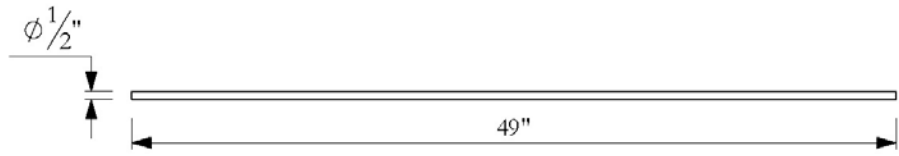

12 B-BAR

8a. $\varnothing 3"$ is typical for all bends on Z-bar and A-bar.

Revisions:				The Texas A&M University System College Station, Texas 77843			
No.	Date	By	Chk	Texas Transportation Institute			
1.				Drawn By	Scale	Sheet No.	Sheet Name
2.				GES	1:10	9 of 9	Rebar b
3.				5" CIP Barrier Anchor			420021-5
4.							

T:\2010-2011\420021-5 5"-CIP-Barrier Anchors\SolidWorks\420021-5 Drawing

MATERIAL USED

TEST NUMBER 420021-5
 TEST NAME 5" Bridge CIP Deck
 DATE 2011-06-23

DATE RECEIVED	ITEM NUMBER	DESCRIPTION	SUPPLIER	HEAT #
2011-05-13	Rebar 03-01	3/8" x 20' grd 60	CMC-Sheplers	3023290
2011-05-10	Rebar 04-22	1/2" x 20' gr 60	CMC-Sheplers	3023512
2011-05-10	Rebar 05-07	5/8" x 20' grd 60	CMC-Sheplers	3023730
2011-05-10	Rebar 08-03	1" x 20' gr. 60	CMC-Sheplers	3022150



CMC STEEL TEXAS
1 STEEL MILL DRIVE
SEGUIN TX 78155-7510

CERTIFIED MILL TEST REPORT
For additional copies call
830-372-8771

are accurate and conform to the reported grade specification

Daniel J. Schacht
Daniel J. Schacht

Quality Assurance Manager

HEAT NO.:3023 290	S	CMC Construction Svcs College Stati	S	CMC Construction Svcs College Stati	Delivery#: 80477293
SECTION: REBAR 10MM (#3) 20'0"	O		H		BOL#: 70168259
420/60	L	10650 State Hwy 30	I	10650 State Hwy 30	CUST PO#: 5079AG
GRADE: ASTM A615-99b Gr 420/60	D	College Station TX	P	College Station TX	CUST P/N:
ROLL DATE: 03/27/2011		US 77845-7950		US 77845-7950	DLVRY LBS / HEAT: 46332.000 LB
MELT DATE: 03/25/2011	T	979 774 5900	T	979 774 5900	DLVRY PCS / HEAT: 6160 EA
	O		O		

Characteristic	Value	Characteristic	Value	Characteristic	Value
C	0.43%				
Mn	0.68%				
P	0.014%				
S	0.031%				
Si	0.19%				
Cu	0.36%				
Cr	0.20%				
Ni	0.18%				
Mo	0.064%				
V	0.003%				
Cb	0.001%				
Sn	0.013%				
Al	0.001%				
Yield Strength test 1	68.7ksi				
Tensile Strength test 1	106.1ksi				
Elongation test 1	12%				
Elongation Gage Lgth test 1	8IN				
Bend Test Diameter	1.313IN				
Bend Test	Passed				

THIS MATERIAL IS FULLY KILLED, 100% MELTED AND MANUFACTURED IN THE USA, WITH NO WELD REPAIR OR MERCURY CONTAMINATION IN THE PROCESS.

REMARKS :



CMC STEEL TEXAS
 1 STEEL MILL DRIVE
 SEGUIN TX 78155-7510

CERTIFIED MILL TEST REPORT
 For additional copies call
 830-372-8771

We hereby certify that the test results presented here
 are accurate and conform to the reported grade specification

Daniel J. Schacht
 Daniel J. Schacht

Quality Assurance Manager

HEAT NO.:30235-12	S	CMC Construction Svcs College Stati	S	CMC Construction Svcs College Stati	Delivery#: 80498409
SECTION: REBAR 13MM (#4) 20'0"	O		H		BOL#: 70176164
420/60	L	10650 State Hwy 30	I	10650 State Hwy 30	CUST PO#: 51755a
GRADE: ASTM A615-09b.Gr 420/60	D	College Station TX	P	College Station TX	CUST P/N:
ROLL DATE: 04/08/2011	US	77845-7950	US	77845-7950	DLVRY LBS / HEAT: 37247.000 LB
MELT DATE: 04/05/2011	T	979 774 5900	T	979 774 5900	DLVRY PCS / HEAT: 2788 EA
	O		O		

Characteristic	Value	Characteristic	Value	Characteristic	Value
C	0.45%				
Mn	0.73%				
P	0.013%				
S	0.028%				
Si	0.18%				
Cu	0.32%				
Cr	0.19%				
Ni	0.17%				
Mo	0.056%				
V	0.002%				
Cb	0.001%				
Sn	0.013%				
Al	0.002%				
Yield Strength test 1	65.1ksi				
Tensile Strength test 1	105.3ksi				
Elongation test 1	13%				
Elongation Gage Lgth test 1	8IN				
Bend Test Diameter	1.750IN				
Bend Test 1	Passed				

THIS MATERIAL IS FULLY KILLED, 100% MELTED AND MANUFACTURED IN THE USA, WITH NO WELD REPAIR OR MERCURY CONTAMINATION IN THE PROCESS.
 REMARKS :

51



CMC STEEL TEXAS
1 STEEL MILL DRIVE
SEGUIN TX 78155-7510

CERTIFIED MILL TEST REPORT
For additional copies call
830-372-8771

We hereby certify that the test results presented here
are accurate and conform to the reported grade specification

Daniel J. Schacht
Daniel J. Schacht
Quality Assurance Manager

HEAT NO.:3023 730	S	CMC Construction Svcs College Stati	S	CMC Construction Svcs College Stati	Delivery#: 80498410
SECTION: REBAR 16MM (#5) 20'0"	O		H		BOL#: 70176163
420/60	L	10650 State Hwy 30	I	10650 State Hwy 30	CUST PO#: 51755a
GRADE: ASTM A615-09b Gr 420/60	D	College Station TX	P	College Station TX	CUST P/N:
ROLL DATE: 04/14/2011		US 77845-7950		US 77845-7950	DLVRY LBS / HEAT: 45990.000 LB
MELT DATE: 04/14/2011	T	979 774 5900	T	979 774 5900	DLVRY PCS / HEAT: 2205 EA
	O		O		

Characteristic	Value	Characteristic	Value	Characteristic	Value
C	0.40%				
Mn	1.05%				
P	0.017%				
S	0.038%				
Si	0.26%				
Cu	0.32%				
Cr	0.16%				
Ni	0.15%				
Mo	0.046%				
V	0.002%				
Cb	0.001%				
Sn	0.013%				
Al	0.000%				
Yield Strength test 1	64.8ksi				
Tensile Strength test 1	104.7ksi				
Elongation test 1	13%				
Elongation Gage Lgth test 1	8IN				
Bend Test Diameter	2.188IN				
Bend Test 1	Passed				

THIS MATERIAL IS FULLY KILLED, 100% MELTED AND MANUFACTURED IN THE USA, WITH NO WELD REPAIR OR MERCURY CONTAMINATION IN THE PROCESS.
REMARKS :

05/03/2011 09:34:20

Page 1 OF 1

52



CMC STEEL TEXAS
1 STEEL MILL DRIVE
SEGUIN TX 78155-7510

CERTIFIED MILL TEST REPORT
For additional copies call
830-372-8771

We hereby certify that the test results presented here
are accurate and conform to the reported grade specification

Daniel J. Schacht
Daniel J. Schacht

Quality Assurance Manager

HEAT NO.:3022150 SECTION: REBAR 25MM (#8) 20'0" 420/60 GRADE: ASTM A615-09b Gr 420/60 ROLL DATE: 02/01/2011 MELT DATE: 01/31/2011	S O L D T O	CMC Construction Svcs College Stati 10650 State Hwy 30 College Station TX US 77845-7950 979 774 5900	S H I P T O	CMC Construction Svcs College Stati 10650 State Hwy 30 College Station TX US 77845-7950 979 774 5900	Delivery#: 80446451 BOL#: 70156833 CUST PO#: 500412 CUST P/N: DLVRY LBS / HEAT: 46992.000 LB DLVRY PCS / HEAT: 880 EA
--	----------------------------	--	----------------------------	--	--

Characteristic	Value	Characteristic	Value	Characteristic	Value
C	0.42%				
Mn	1.13%				
P	0.017%				
S	0.026%				
Si	0.25%				
Cu	0.24%				
Cr	0.18%				
Ni	0.17%				
Mo	0.066%				
V	0.002%				
Cb	0.001%				
Sn	0.011%				
Al	0.002%				
Yield Strength test 1	66.9ksi				
Tensile Strength test 1	109.5ksi				
Elongation test 1	15%				
Elongation Gage Lgth test 1	8IN				
Bend Test Diameter	5.000IN				
Bend Test	Passed				

THIS MATERIAL IS FULLY-KILLED, 100% MELTED AND MANUFACTURED IN THE USA, WITH NO WELD REPAIR OR MERCURY CONTAMINATION IN THE PROCESS.

REMARKS :

02/04/2011 17:04:48

Page 1 OF 1

53

APPENDIX C. TEST VEHICLE PROPERTIES AND INFORMATION

Table C1. Vehicle Properties for Test No. 420021-5.

Date: 2011-06-20 Test No.: 420021-5 VIN No.: 1D7HA18N355301594
 Year: 2005 Make: Dodge Model: Ram 1500
 Tire Size: 245/75R17 Tire Inflation Pressure: 35 psi
 Tread Type: Highway Odometer: 134508

Note any damage to the vehicle prior to test: _____

• Denotes accelerometer location.

NOTES: _____

Engine Type: V-8
 Engine CID: 4.7 kuter

Transmission Type:
 Auto or Manual
 FWD RWD 4WD

Optional Equipment:

Dummy Data:
 Type: None
 Mass: _____
 Seat Position: _____

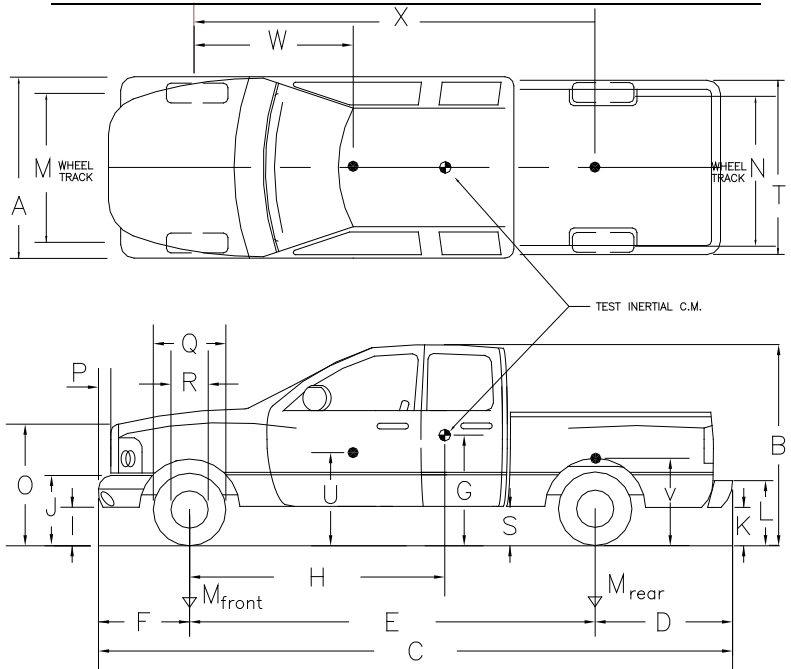

Geometry: inches

A	<u>77.00</u>	F	<u>39.00</u>	K	<u>20.50</u>	P	<u>3.00</u>	U	<u>27.50</u>
B	<u>73.25</u>	G	<u>28.38</u>	L	<u>28.75</u>	Q	<u>29.50</u>	V	<u>30.00</u>
C	<u>227.00</u>	H	<u>63.60</u>	M	<u>68.25</u>	R	<u>18.50</u>	W	<u>63.50</u>
D	<u>47.50</u>	I	<u>13.50</u>	N	<u>27.25</u>	S	<u>14.25</u>	X	<u>87.00</u>
E	<u>140.50</u>	J	<u>26.00</u>	O	<u>44.75</u>	T	<u>75.50</u>		

Wheel Center Ht Front 14.125 Wheel Well Clearance (FR) 6.125 Frame Ht (FR) 16.625

Wheel Center Ht Rear 14.25 Wheel Well Clearance (RR) 11.25 Frame Ht (RR) 24.25

RANGE LIMIT: A=78 ±2 inches; C=237 ±13 inches; E=148 ±12 inches; F=39 ±3 inches; G = > 28 inches; H = 63 ±4 inches; O=43 ±4 inches; M+N/2=67 ±1.5 inches

GVWR Ratings:	Mass: lb	Curb	Test Inertial	Gross Static
Front <u>3650</u>	M_{front} <u>2728</u>	<u>2728</u>	<u>2739</u> Allowable	Allowable
Back <u>3900</u>	M_{rear} <u>1940</u>	<u>1940</u>	<u>2265</u> Range	Range
Total <u>6650</u>	M_{Total} <u>4668</u>	<u>4668</u>	<u>5004</u> 5000 ±110 lb	5000 ±110 lb

Mass Distribution:

lb LF: 1394 RF: 1345 LR: 1114 RR: 1151

Table C2. Vehicle Vertical CG Parametric Measurements for Test No. 420021-5.

Date: 2011-06-20 Test No.: 420021-5 VIN: 1D7HA18N355301594

Year: 2005 Make: Dodge Model: Ram 1500

Body Style: Quad-Cab Mileage: 134508

Engine: 5.7 liter Transmission: Automatic

Fuel Level: Empty Ballast: 275 lb (440 lb max)

Tire Pressure: Front: 35 psi Rear: 35 psi Size: 245/75R17

Measured Vehicle Weights: (lb)

LF: 1394 RF: 1345 Front Axle: 2739

LR: 1114 RR: 1151 Rear Axle: 2265

Left: 2508 Right: 2496 Total: 5004

5000 ±110 lb allowed

Wheel Base: 140.5 inches Track: F: 68.25 inches R: 67.25 inches

148 ±12 inches allowed

Track = (F+R)/2 = 67 ±1.5 inches allowed

Center of Gravity, SAE J874 Suspension Method

X: 63.60 in Rear of Front Axle (63 ±4 inches allowed)

Y: -0.08 in Left - Right + of Vehicle Centerline

Z: 28.375 in Above Ground (minumum 28.0 inches allowed)

Hood Height: 44.75 inches Front Bumper Height: 26.00 inches

43 ±4 inches allowed

Front Overhang: 39.00 inches Rear Bumper Height: 28.75 inches

39 ±3 inches allowed

Overall Length: 227.00 inches

237 ±13 inches allowed

Table C3. Exterior Crush Measurements for Test No. 420021-5.

Date: 2011-06-20 Test No.: 420021-5 VIN No.: 1D7HA18N355301594
 Year: 2005 Make: Dodge Model: Ram 1500

VEHICLE CRUSH MEASUREMENT SHEET¹

Complete When Applicable	
End Damage	Side Damage
Undeformed end width _____	Bowing: B1 _____ X1 _____
Corner shift: A1 _____	B2 _____ X2 _____
A2 _____	
End shift at frame (CDC)	Bowing constant
(check one)	$\frac{X1 + X2}{2} =$ _____
< 4 inches _____	
≥ 4 inches _____	

Note: Measure C₁ to C₆ from Driver to Passenger side in Front or Rear impacts – Rear to Front in Side Impacts.

Specific Impact Number	Plane* of C-Measurements	Direct Damage		Field L**	C ₁	C ₂	C ₃	C ₄	C ₅	C ₆	±D
		Width** (CDC)	Max*** Crush								
1	Front plane at bmpr ht	22	16	28	0	2	7	11	14	16	+14
2	Side plane at bmpr ht	22	18	62	3.5	5.5	---	---	14	18	-74
	Measurements recorded										
	in inches										

¹Table taken from National Accident Sampling System (NASS).

*Identify the plane at which the C-measurements are taken (e.g., at bumper, above bumper, at sill, above sill, at beltline, etc.) or label adjustments (e.g., free space).

Free space value is defined as the distance between the baseline and the original body contour taken at the individual C locations. This may include the following: bumper lead, bumper taper, side protrusion, side taper, etc. Record the value for each C-measurement and maximum crush.

**Measure and document on the vehicle diagram the beginning or end of the direct damage width and field L (e.g., side damage with respect to undamaged axle).

***Measure and document on the vehicle diagram the location of the maximum crush.

Note: Use as many lines/columns as necessary to describe each damage profile.

Table C4. Occupant Compartment Measurements for Test No. 420021-5.

Date: 2011-06-20 Test No.: 420021-5 VIN No.: 1D7HA18N355301594
 Year: 2005 Make: Dodge Model: Ram 1500

OCCUPANT COMPARTMENT DEFORMATION MEASUREMENT

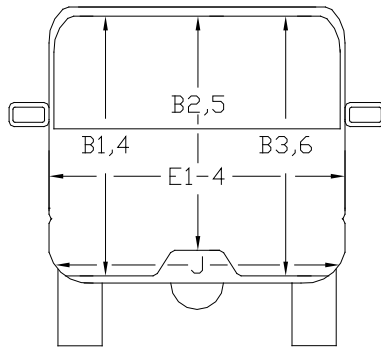
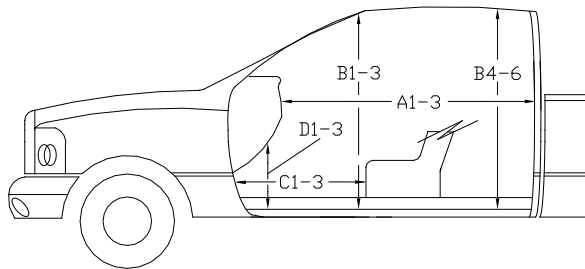
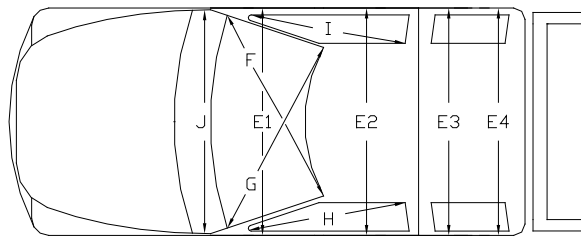

	Before (inches)	After (inches)
A1	64.50	64.50
A2	64.50	64.00
A3	65.50	64.50
B1	45.00	45.00
B2	39.25	38.75
B3	45.50	44.75
B4	42.25	42.25
B5	42.75	42.75
B6	42.25	42.25
C1	27.50	27.50
C2	----	----
C3	27.50	26.50
D1	12.75	12.75
D2	2.50	2.50
D3	11.25	11.75
E1	64.25	64.75
E2	64.25	64.50
E3	64.00	62.25
E4	64.00	63.50
F	60.00	60.00
G	60.00	60.00
H	39.50	39.50
I	39.50	39.50
J*	62.75	57.00

*Lateral area across the cab from driver's side kickpanel to passenger's side kickpanel.

APPENDIX D. SEQUENTIAL PHOTOGRAPHS



0.000 s

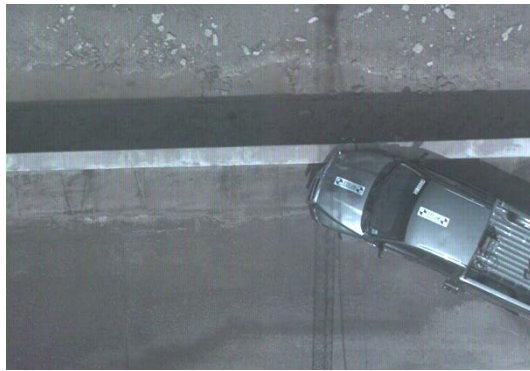

0.051 s



0.102 s



0.153 s



Figure D1. Sequential Photographs for Test No. 420021-5 (Overhead and Frontal Views).



0.204s



0.255 s

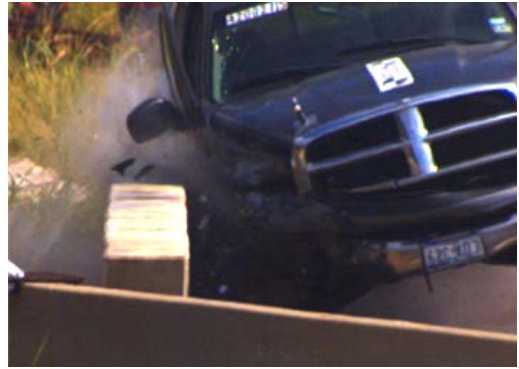

0.306 s

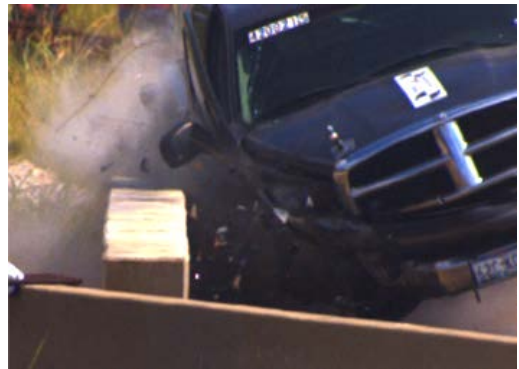

0.357 s

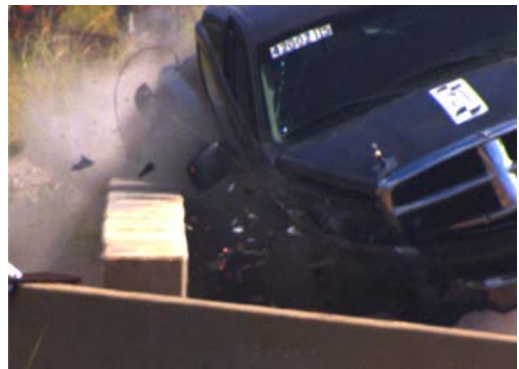

**Figure D1. Sequential Photographs for Test No. 420021-5
(Overhead and Frontal Views) (continued).**



0.000 s



0.204 s



0.051 s



0.255 s



0.102 s



0.306 s



0.153 s



0.357 s

Figure D2. Sequential Photographs for Test No. 420021-5 (Rear View).

Roll, Pitch, and Yaw Angles

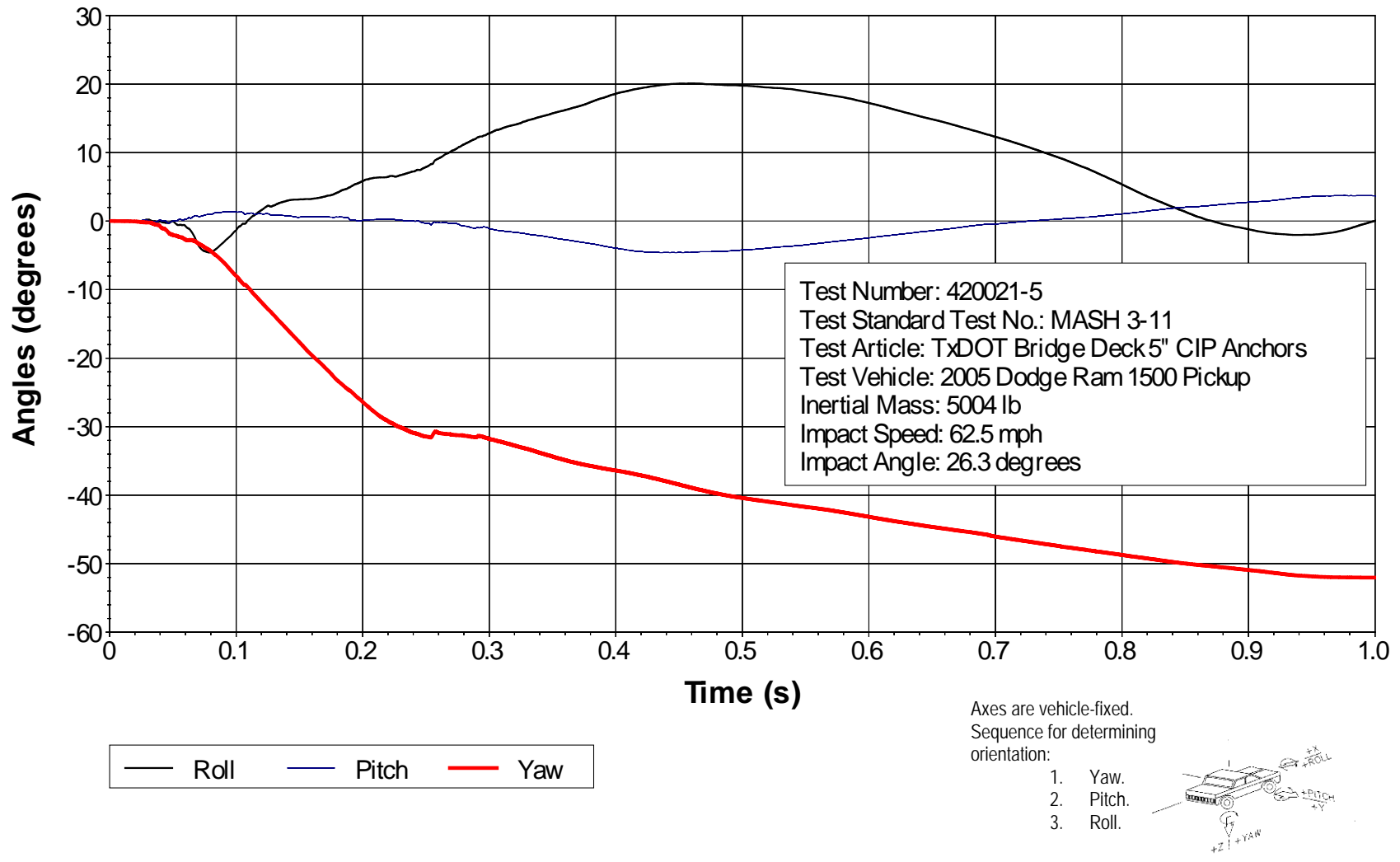
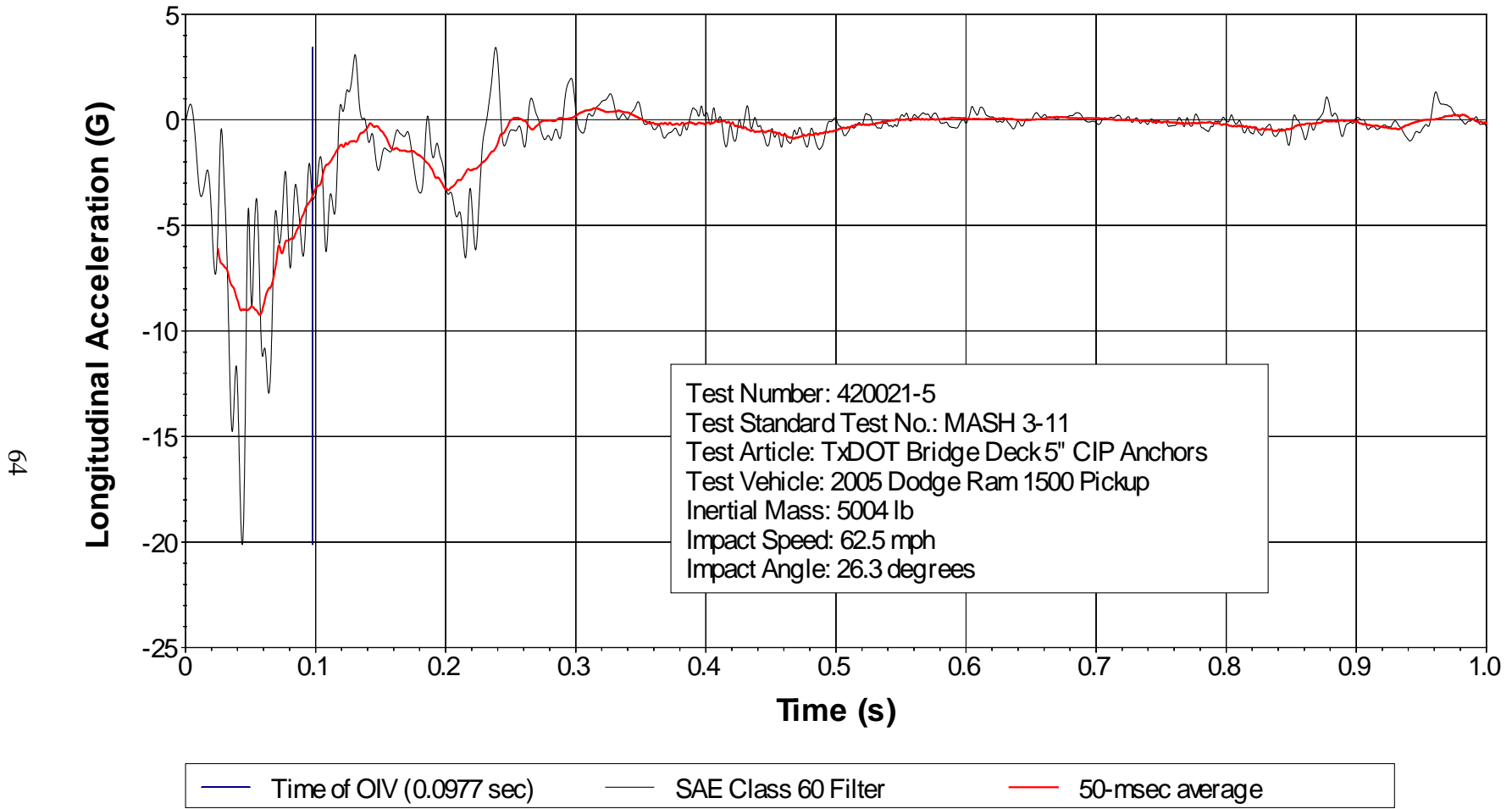

Figure E1. Vehicle Angular Displacements for Test No. 420021-5.

X Acceleration at CG



**Figure E2. Vehicle Longitudinal Accelerometer Trace for Test No. 420021-5
(Accelerometer Located at Center of Gravity).**

Y Acceleration at CG

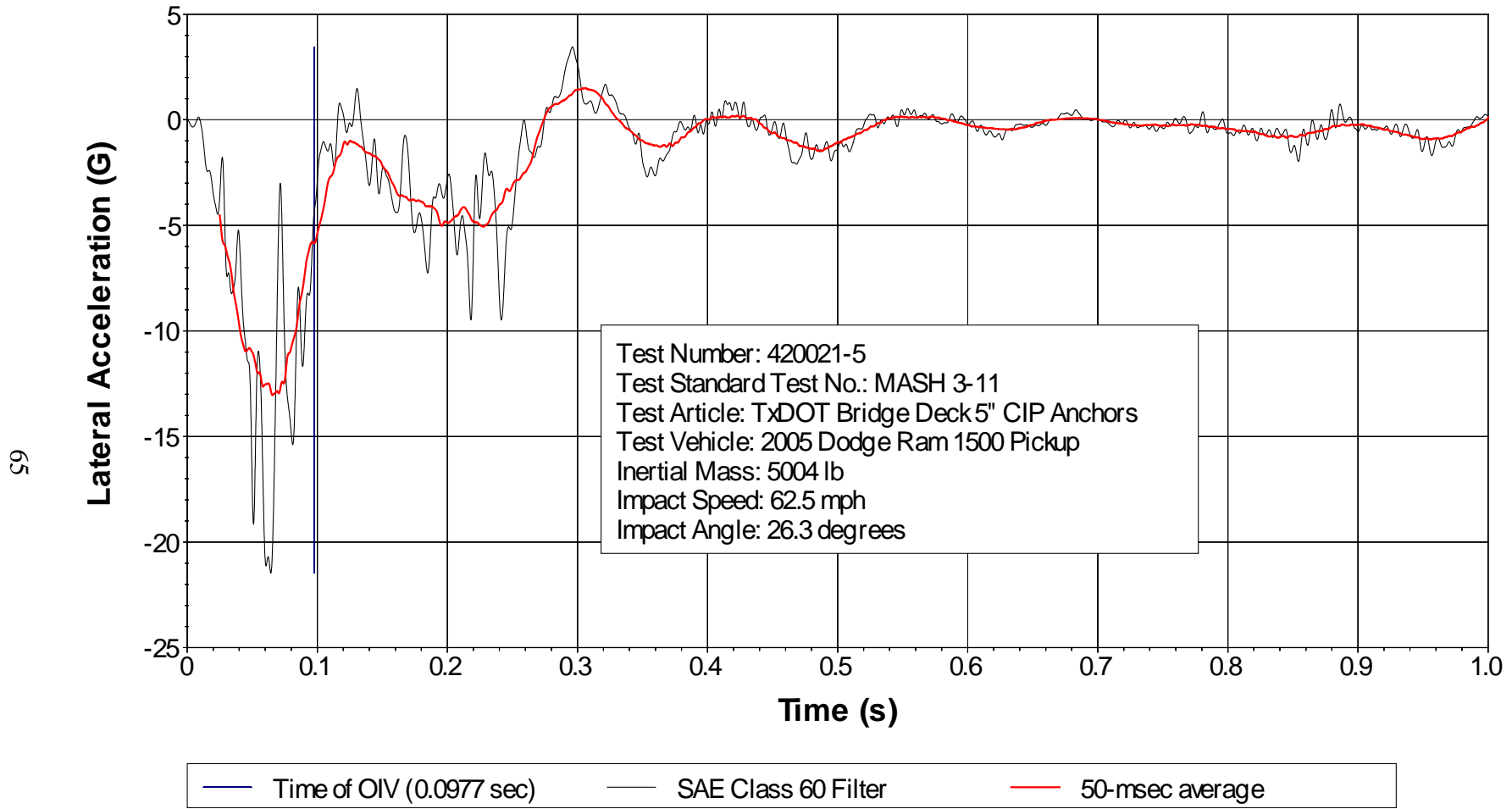

**Figure E3. Vehicle Lateral Accelerometer Trace for Test No. 420021-5
(Accelerometer Located at Center of Gravity).**

Z Acceleration at CG

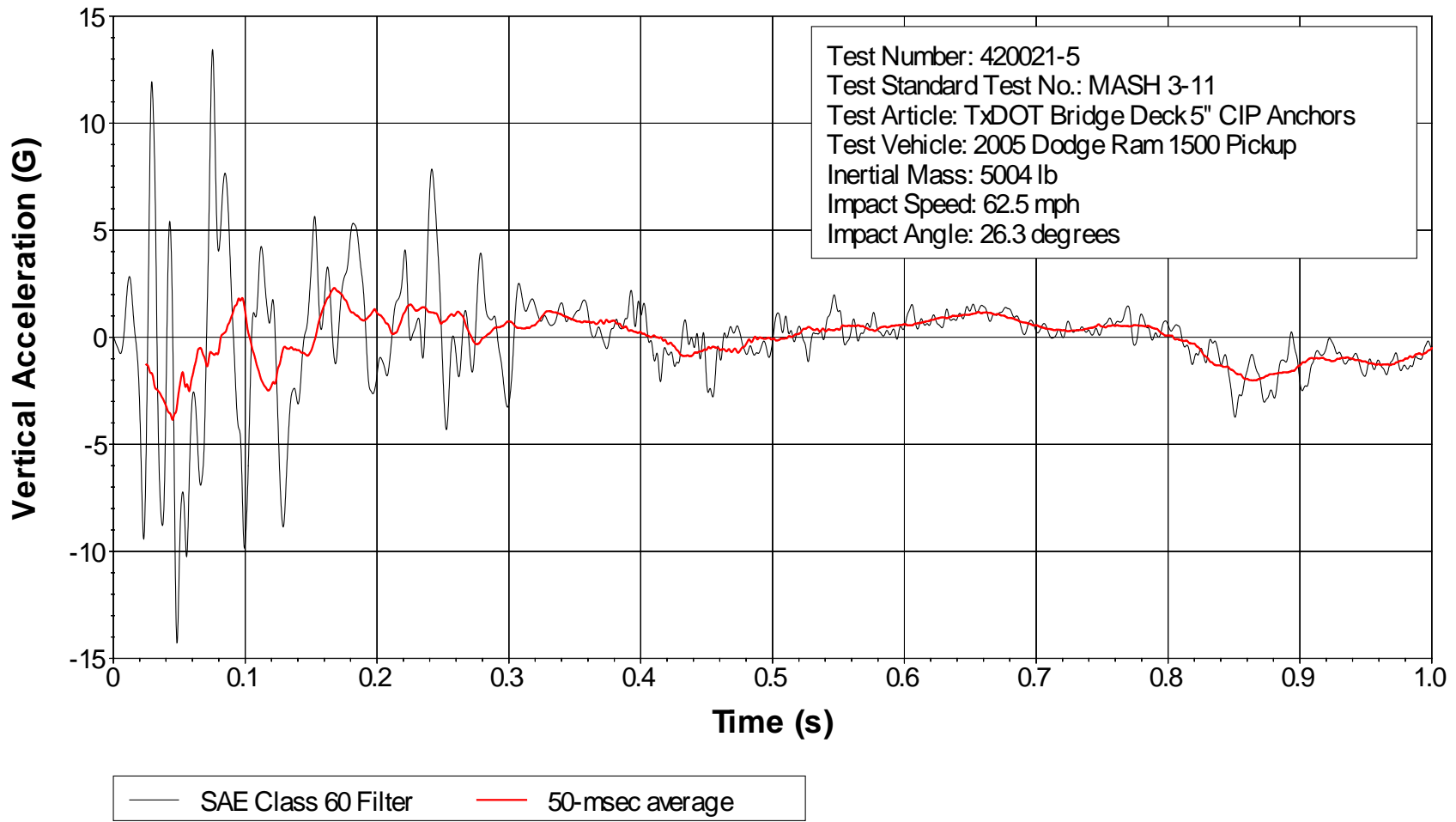
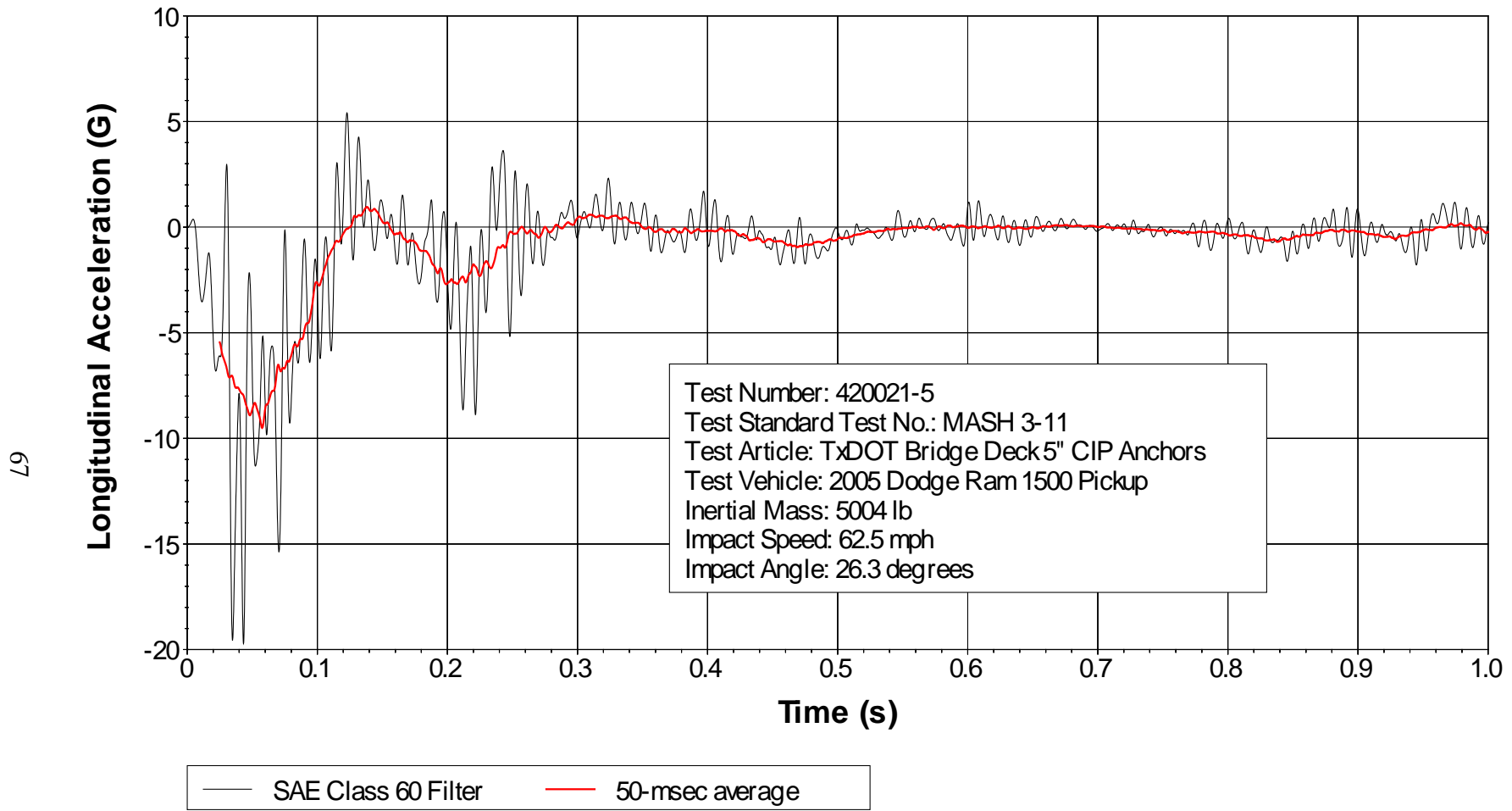

Figure E4. Vehicle Vertical Accelerometer Trace for Test No. 420021-5
(Accelerometer Located at Center of Gravity).

X Acceleration over Rear Axle



**Figure E5. Vehicle Longitudinal Accelerometer Trace for Test No. 420021-5
(Accelerometer Located over Rear Axle).**

Y Acceleration over Rear Axle

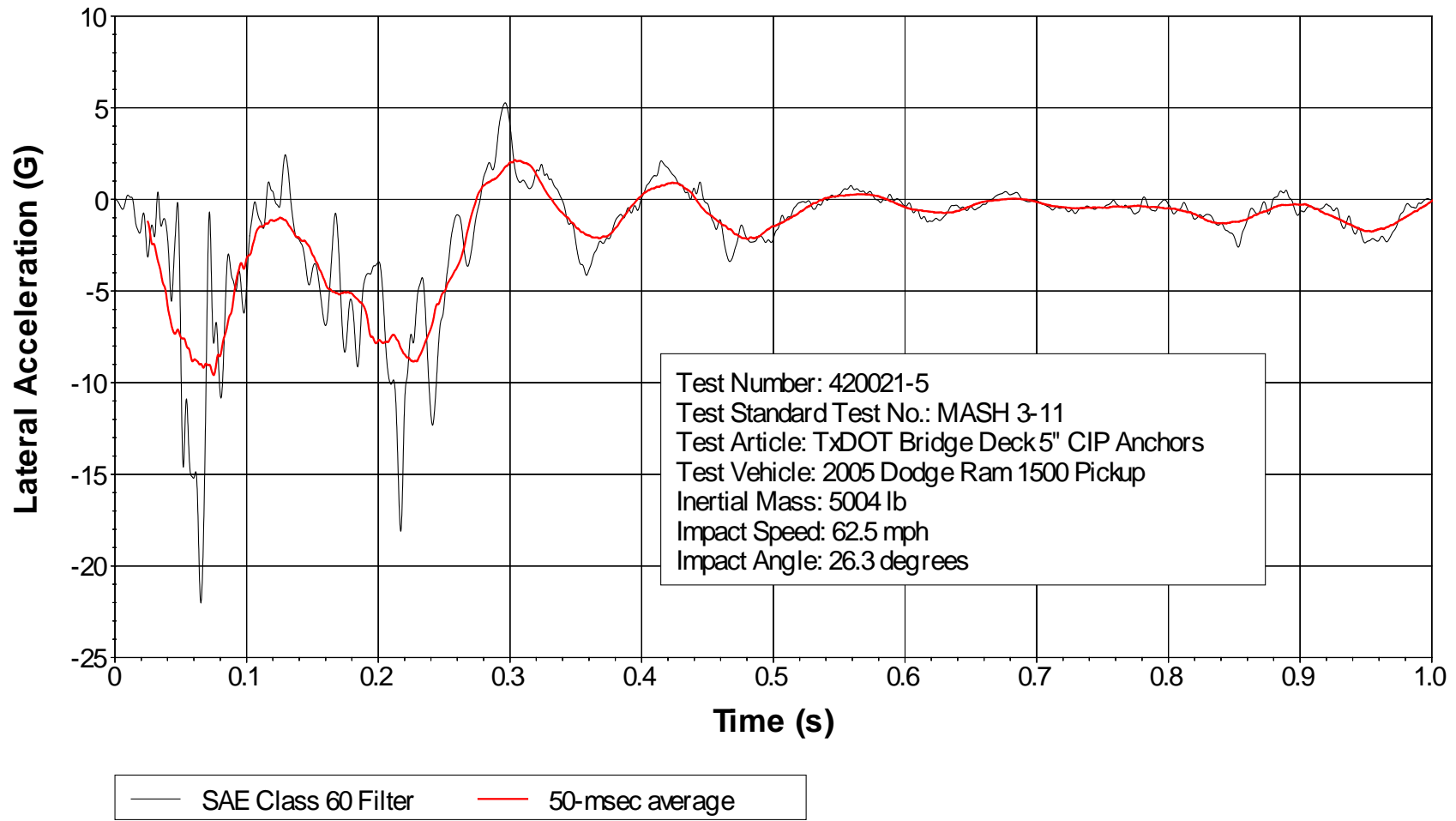

**Figure E6. Vehicle Lateral Accelerometer Trace for Test No. 420021-5
(Accelerometer Located over Rear Axle).**

Z Acceleration over Rear Axle

69

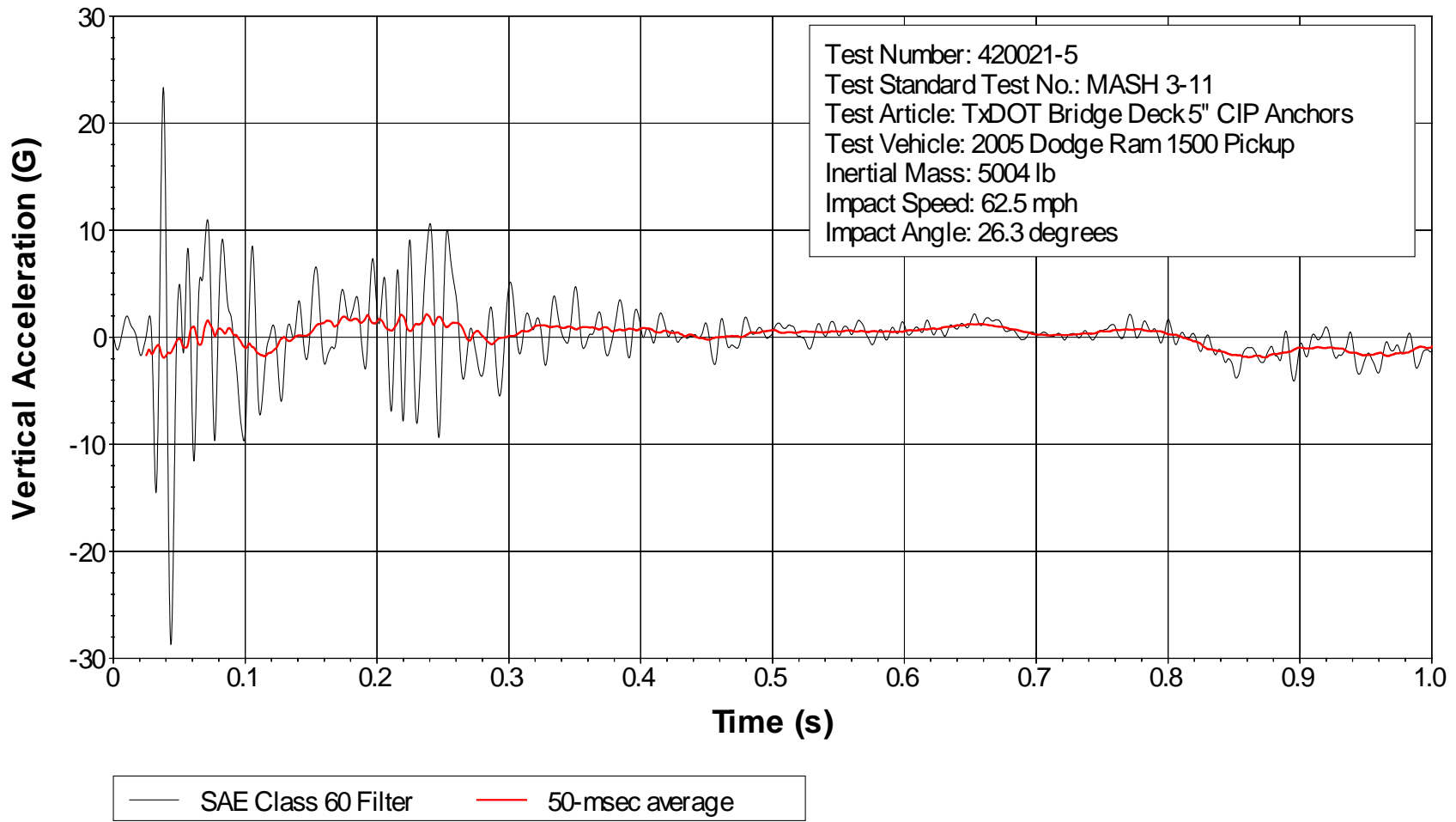

**Figure E7. Vehicle Vertical Accelerometer Trace for Test No. 420021-5
(Accelerometer Located over Rear Axle).**