



DEVELOPMENT AND EVALUATION OF A *MASH* TL-3 31-INCH W-BEAM MEDIAN BARRIER



Crash testing performed at:
TTI Proving Ground
3100 SH 47, Building 7091
Bryan, TX 77807

Test Report 9-1002-12-8

Cooperative Research Program

TEXAS A&M TRANSPORTATION INSTITUTE
COLLEGE STATION, TEXAS

TEXAS DEPARTMENT OF TRANSPORTATION

in cooperation with the
Federal Highway Administration and the
Texas Department of Transportation

<http://tti.tamu.edu/documents/9-1002-12-8.pdf>

1. Report No. FHWA/TX-14/9-1002-12-8		2. Government Accession No.		3. Recipient's Catalog No.	
4. Title and Subtitle DEVELOPMENT AND EVALUATION OF A MASH TL-3 31-INCH W-BEAM MEDIAN BARRIER				5. Report Date October 2013	
				6. Performing Organization Code	
7. Author(s) Akram Y. Abu-Odeh, Roger P. Bligh, Melinda L. Mason, and Wanda L. Menges				8. Performing Organization Report No. Test Report No. 9-1002-12-8	
9. Performing Organization Name and Address Texas A&M Transportation Institute Proving Ground College Station, Texas 77843-3135				10. Work Unit No. (TRAIS)	
				11. Contract or Grant No. Project 9-1002-12	
12. Sponsoring Agency Name and Address Texas Department of Transportation Research and Technology Implementation Office 125 E. 11 th Street Austin, Texas 78701-2483				13. Type of Report and Period Covered Test Report: July 2011–August 2013	
				14. Sponsoring Agency Code	
15. Supplementary Notes Project performed in cooperation with the Texas Department of Transportation and the Federal Highway Administration. Project Title: Roadside Safety Device Crash Testing Program URL: http://tti.tamu.edu/documents/9-1002-12-8.pdf					
16. Abstract <p>Typically, when the G4(1S) W-beam barrier is impacted in a roadside application, the W-beam rail element deforms, the support posts are displaced through the soil, and the vehicle is redirected. During the impact sequence, the rail becomes detached from the post by means of the post bolt pulling out of the rail slot as the post displaces rearward. However, in the MB4 steel post W-beam median barrier, the addition of the rear W-beam rail element provides additional lateral stiffness and post constraint. This changes the post behavior and vehicle-post interaction. In a test of the 27-inch tall MB4 median barrier, the impacting pickup truck climbed and vaulted over the barrier.</p> <p>A taller 30-inch version of the MB4 W-beam median barrier (AASHTO Designation SGM06a&b) incorporates a C6×8.2 rub-rail channel to help mitigate vehicle-post snagging. However, the rub-rail may still permit the pickup to climb the barrier.</p> <p>The purpose of this project was to develop and evaluate a W-beam median barrier that would meet the strength and safety performance criteria of the AASHTO <i>Manual for Assessing Safety Hardware (MASH)</i>. A 31-inch tall W-beam median barrier with rail splices offset from the posts and 8-inch offset blocks (AASHTO Designation SGM06a) was successfully crash tested in accordance with <i>MASH</i>.</p>					
17. Key Words Longitudinal Barriers, Guardrail, W-Beam, Median Barrier, LS-DYNA, Finite Element Analysis, FEA, Crash Testing, Roadside Safety			18. Distribution Statement No restrictions. This document is available to the public through NTIS: National Technical Information Service Alexandria, Virginia 22312 http://www.ntis.gov		
19. Security Classif.(of this report) Unclassified		20. Security Classif.(of this page) Unclassified		21. No. of Pages 112	22. Price

**DEVELOPMENT AND EVALUATION OF A *MASH* TL-3 31-INCH
W-BEAM MEDIAN BARRIER**

by

Akram Y. Abu-Odeh
Research Scientist
Texas A&M Transportation Institute

Roger P. Bligh, P.E., Ph.D.
Research Engineer
Texas A&M Transportation Institute

Melinda L. Mason
Student Technician I
Texas A&M Transportation Institute

and

Wanda L. Menges
Research Specialist
Texas A&M Transportation Institute

Report 9-1002-12-8
Project 9-1002
Project Title: Roadside Safety Device Crash Testing Program

Performed in cooperation with the
Texas Department of Transportation
and the
Federal Highway Administration

October 2013

TEXAS A&M TRANSPORTATION INSTITUTE
College Station, Texas 77843-3135

DISCLAIMER

This research was performed in cooperation with the Texas Department of Transportation (TxDOT) and the Federal Highway Administration (FHWA). The contents of this report reflect the views of the authors, who are responsible for the facts and the accuracy of the data presented herein. The contents do not necessarily reflect the official view or policies of the FHWA or TxDOT. This report does not constitute a standard, specification, or regulation, and its contents are not intended for construction, bidding, or permit purposes. In addition, the above listed agencies assume no liability for its contents or use thereof. The United States Government and the State of Texas do not endorse products or manufacturers. Trade or manufacturers' names appear herein solely because they are considered essential to the object of this report. The engineer in charge of the project was Roger P. Bligh, P.E. (Texas, #78550).

TTI PROVING GROUND DISCLAIMER

The results of the crash testing reported herein apply only to the article being tested.

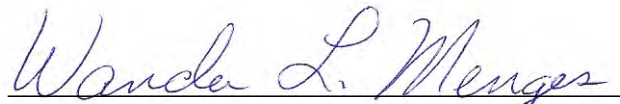

Wanda L. Menges, Research Specialist
Deputy Quality Manager

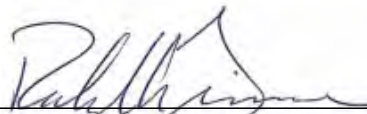

Richard A. Zimmer, Senior Research Specialist
Test Facility Manager
Quality Manager
Technical Manager

ACKNOWLEDGMENTS

This research project was conducted under a cooperative program between the Texas A&M Transportation Institute, the Texas Department of Transportation, and the Federal Highway Administration. The TxDOT project manager was Wade Odell (RTI). Rory Meza (DES) also contributed significantly to the project. The authors acknowledge and appreciate their guidance and assistance. This work was partially supported by the U.S. Department of Transportation, the Illinois Department of Transportation, and the Transportation Research and Analysis Computing Center, who provided resources and supercomputer hours for running the simulation cases for this project.

TABLE OF CONTENTS

	Page
LIST OF FIGURES	ix
LIST OF TABLES	xi
CHAPTER 1. INTRODUCTION	1
1.1 INTRODUCTION	1
1.2 BACKGROUND	1
1.2.1 Previous Evaluation of 27-Inch G4(1S) W-Beam Median Barrier.....	1
1.2.2 Test Installation Used for Evaluation of 27-Inch G4(1S) W-Beam Median Barrier..	2
1.2.3 <i>MASH</i> Test 3-10 on 27-Inch G4(1S) W-Beam Median Barrier	2
1.2.4 <i>MASH</i> Test 3-11 on 27-Inch G4(1S) W-Beam Median Barrier	3
1.2.5 <i>MASH</i> , FHWA, and the 27-Inch G4(1S) W-Beam Median Barrier	3
1.3 OBJECTIVES/SCOPE OF RESEARCH	4
CHAPTER 2. SIMULATION RESULTS	5
2.1 SIMULATION RESULTS	7
2.1.1 TL 3-11 Mid-Span Impact	7
2.1.2 TL 3-11 At-Post Impact	12
2.2 SIMULATION CONCLUSIONS.....	15
CHAPTER 3. SYSTEM DETAILS	17
3.1 TEST ARTICLE DESIGN AND CONSTRUCTION.....	17
3.2 MATERIAL SPECIFICATIONS	17
3.3 SOIL CONDITIONS	17
CHAPTER 4. TEST REQUIREMENTS AND EVALUATION CRITERIA.....	23
4.1 CRASH TEST MATRIX.....	23
4.2 EVALUATION CRITERIA	23
CHAPTER 5. CRASH TEST PROCEDURES	25
5.1 TEST FACILITY	25
5.2 VEHICLE TOW AND GUIDANCE PROCEDURES.....	25
5.3 DATA ACQUISITION SYSTEMS.....	25
5.3.1 Vehicle Instrumentation and Data Processing	25
5.3.2 Anthropomorphic Dummy Instrumentation	26
5.3.3 Photographic Instrumentation and Data Processing	26
CHAPTER 6. CRASH TEST RESULTS FOR <i>MASH</i> TEST 3-10.....	27
6.1 TEST DESIGNATION AND ACTUAL IMPACT CONDITIONS	27
6.2 TEST VEHICLE.....	27
6.3 WEATHER CONDITIONS.....	27
6.4 TEST DESCRIPTION	27
6.5 DAMAGE TO TEST INSTALLATION	30
6.6 VEHICLE DAMAGE.....	30
6.7 OCCUPANT RISK FACTORS.....	30
6.1 ASSESSMENT OF TEST RESULTS	36
6.1.1 Structural Adequacy.....	36
6.1.2 Occupant Risk.....	36
6.1.3 Vehicle Trajectory	37

TABLE OF CONTENTS (CONTINUED)

	Page
CHAPTER 7. CRASH TEST RESULTS FOR <i>MASH</i> TEST 3-11	39
7.1 TEST DESIGNATION AND ACTUAL IMPACT CONDITIONS	39
7.2 TEST VEHICLE	39
7.3 WEATHER CONDITIONS	39
7.4 TEST DESCRIPTION	39
7.5 DAMAGE TO TEST INSTALLATION	42
7.6 VEHICLE DAMAGE	42
7.7 OCCUPANT RISK FACTORS	42
7.1 ASSESSMENT OF TEST RESULTS	48
7.1.1 Structural Adequacy	48
7.1.2 Occupant Risk	48
7.1.3 Vehicle Trajectory	49
CHAPTER 8. SUMMARY AND CONCLUSIONS	51
8.1 SUMMARY OF TEST RESULTS	51
8.1.1 <i>MASH</i> Test 3-10 (Crash Test No. 490023-3)	51
8.1.2 <i>MASH</i> Test 3-11 (Crash Test No. 490023-4)	51
8.2 CONCLUSIONS	51
CHAPTER 9. IMPLEMENTATION STATEMENT	55
REFERENCES	57
APPENDIX A. DETAILS OF THE TEST ARTICLE	59
APPENDIX B. CERTIFICATION DOCUMENTATION	63
APPENDIX C. SOIL PROPERTIES	67
APPENDIX D. <i>MASH</i> TEST 3-10 (CRASH TEST NO. 490023-3)	71
APPENDIX E. <i>MASH</i> TEST 3-11 (CRASH TEST NO. 490023-4)	85

LIST OF FIGURES

	Page
Figure 1.1. Cross Section of the 27-Inch G4(1S) W-Beam Median Barrier	3
Figure 2.1. Meshing Scheme of the 8-Ft Post Model (Left) and the 12 Gauge W-Beam Rail (Right)	5
Figure 2.2. Finite Element Model of the 27-inch Median Barrier	6
Figure 2.3. Simulation of the <i>MASH</i> 3-11 as the 2270P Vehicle Vaults over the 27-inch Median Barrier	6
Figure 2.4. Model of the 31-Inch Median W-Beam Guardrail with the 2270P Vehicle Model	7
Figure 2.5. Views of Vehicle Behavior for Mid-Span Impact Simulation Case	8
Figure 2.6. Silverado Model at Maximum Roll for Mid-Span Impact	8
Figure 2.7. Silverado Model at Maximum Pitch for Mid-Span Impact	9
Figure 2.8. Silverado Model at Maximum Yaw for Mid-Span Impact	9
Figure 2.9. Top View of Vehicle Exit for Mid-Span Impact	9
Figure 2.10. Top View of System's Maximum Deflection for Mid-Span Impact	10
Figure 2.11. Contours of W-Beam Plastic Strain for Mid-Span Impact	10
Figure 2.12. Roll, Pitch, and Yaw Angle for Mid-Span Impact	10
Figure 2.13. Summary of Simulation Results for TL 3-11 for Mid-Span Impact	11
Figure 2.14. Views of Vehicle Behavior for At-Post Impact Simulation Case	12
Figure 2.15. Silverado Model at Maximum Roll for At-Post Impact	13
Figure 2.16. Silverado Model at Maximum Pitch for At-Post Impact	13
Figure 2.17. Silverado Model at Maximum Yaw for At-Post Impact	13
Figure 2.18. Top View of Vehicle Exit for At-Post Impact	14
Figure 2.19. Top View of System's Maximum Deflection for At-Post Impact	14
Figure 2.20. Contours of W-Beam Plastic Strain for At-Post Impact	15
Figure 2.21. Roll, Pitch, and Yaw Angles for At-Post Impact	15
Figure 2.22. Summary of Simulation Results for TL-3-11 for At-Post Impact	16
Figure 3.1. Layout of the TxDOT 31-Inch W-Beam Median Barrier	19
Figure 3.2. Cross-Section of the TxDOT 31-Inch W-Beam Median Barrier	20
Figure 3.3. TxDOT 31-inch W-Beam Median Barrier before Testing	21
Figure 6.1. Vehicle/Installation Geometrics for Test No. 490023-3	28
Figure 6.2. Vehicle before Test No. 490023-3	29
Figure 6.3. Vehicle/Installation Positions after Test No. 490023-3	31
Figure 6.4. Installation after Test No. 490023-3	32
Figure 6.5. Vehicle after Test No. 490023-3	33
Figure 6.6. Interior of Vehicle for Test No. 490023-3	34
Figure 6.7. Summary of Results for <i>MASH</i> Test 3-10 on the TxDOT 31-Inch W-Beam Median Barrier	35
Figure 7.1. Vehicle/Installation Geometrics for Test No. 490023-4	40
Figure 7.2. Vehicle before Test No. 490023-4	41
Figure 7.3. Vehicle/Installation Positions after Test No. 490023-4	43
Figure 7.4. Installation after Test No. 490023-4	44
Figure 7.5. Vehicle after Test No. 490023-4	45

LIST OF FIGURES (CONTINUED)

		Page
Figure 7.6.	Interior of Vehicle for Test No. 490023-4.....	46
Figure 7.7.	Summary of Results for <i>MASH</i> Test 3-11 on the TxDOT 31-Inch W-Beam Median Barrier	47
Figure D1.	Sequential Photographs for Test No. 490023-3 (Overhead and Frontal Views).....	74
Figure D2.	Sequential Photographs for Test No. 490023-3 (Rear View).....	76
Figure D3.	Vehicle Angular Displacements for Test No. 490023-3.....	77
Figure D4.	Vehicle Longitudinal Accelerometer Trace for Test No. 490023-3 (Accelerometer Located at Center of Gravity).....	78
Figure D5.	Vehicle Lateral Accelerometer Trace for Test No. 490023-3 (Accelerometer Located at Center of Gravity).....	79
Figure D6.	Vehicle Vertical Accelerometer Trace for Test No. 490023-3 (Accelerometer Located at Center of Gravity).....	80
Figure D7.	Vehicle Longitudinal Accelerometer Trace for Test No. 490023-3 (Accelerometer Located Rear of Center of Gravity).....	81
Figure D8.	Vehicle Lateral Accelerometer Trace for Test No. 490023-3 (Accelerometer Located Rear of Center of Gravity).....	82
Figure D9.	Vehicle Vertical Accelerometer Trace for Test No. 490023-3 (Accelerometer Located Rear of Center of Gravity).....	83
Figure E1.	Sequential Photographs for Test No. 490023-4 (Overhead and Frontal Views).....	89
Figure E2.	Sequential Photographs for Test No. 490023-4 (Rear View).....	91
Figure E3.	Vehicle Angular Displacements for Test No. 490023-4.....	92
Figure E4.	Vehicle Longitudinal Accelerometer Trace for Test No. 490023-4 (Accelerometer Located at Center of Gravity).....	93
Figure E5.	Vehicle Lateral Accelerometer Trace for Test No. 490023-4 (Accelerometer Located at Center of Gravity).....	94
Figure E6.	Vehicle Vertical Accelerometer Trace for Test No. 490023-4 (Accelerometer Located at Center of Gravity).....	95
Figure E7.	Vehicle Longitudinal Accelerometer Trace for Test No. 490023-4 (Accelerometer Located Rear of Center of Gravity).....	96
Figure E8.	Vehicle Lateral Accelerometer Trace for Test No. 490023-4 (Accelerometer Located Rear of Center of Gravity).....	97
Figure E9.	Vehicle Vertical Accelerometer Trace for Test No. 490023-4 (Accelerometer Located Rear of Center of Gravity).....	98

LIST OF TABLES

	Page
Table 2.1.	TRAP Output Summary for Mid-Span Impact Case. 8
Table 2.2.	TRAP Output Summary for At-Post Impact Case. 12
Table 8.1.	Performance Evaluation Summary for <i>MASH</i> Test 3-10 on the TxDOT 31-Inch W-Beam Median Barrier. 52
Table 8.2.	Performance Evaluation Summary for <i>MASH</i> Test 3-11 on the TxDOT 31-Inch W-Beam Median Barrier. 53
Table C1.	Test Day Static Soil Strength Documentation for Test No. 490023-3. 67
Table C2.	Test Day Static Soil Strength Documentation for Test No. 490023-4. 68
Table C3.	Summary of Strong Soil Test Results for Establishing Installation Procedure. ... 69
Table D1.	Vehicle Properties for Test No. 490023-3. 71
Table D2.	Exterior Crush Measurements for Test No. 490023-3. 72
Table D3.	Occupant Compartment Measurements for Test No. 490023-3. 73
Table E1.	Vehicle Properties for Test No. 490023-4. 85
Table E2.	Parametric Measurements for Vertical CG on 2270P Vehicle for Test No. 490023-4. 86
Table E3.	Exterior Crush Measurements for Test No. 490023-4. 87
Table E4.	Occupant Compartment Measurements for Test No. 490023-4. 88

CHAPTER 1. INTRODUCTION

1.1 INTRODUCTION

The project under which the current research was conducted was set up to provide the Texas Department of Transportation (TxDOT) with a mechanism to quickly and effectively evaluate high-priority issues related to roadside safety devices. Roadside safety devices shield motorists from roadside hazards such as non-traversable terrain and fixed objects. To maintain the desired level of safety for the motoring public, these safety devices must be designed to accommodate a variety of site conditions, placement locations, and a changing vehicle fleet. Periodically, there is a need to assess the compliance of existing safety devices with current vehicle testing criteria and develop new devices that address identified needs.

Under this project, roadside safety issues were identified and prioritized for investigation. Each roadside safety issue was addressed with a separate work plan, and the results are summarized in individual test reports.

1.2 BACKGROUND

1.2.1 Previous Evaluation of 27-Inch MB4 W-Beam Median Barrier

In a National Cooperative Highway Research Program (NCHRP) project in 2008–2009, Texas A&M Transportation Institute (TTI) researchers conducted a survey of the State Departments of Transportation (DOTs) to determine usage rates for various types of non-proprietary roadside safety hardware. Additionally, they reviewed crash tests performed under NCHRP Project 22-14(02), TxDOT Project 0-5526, and numerous other projects following *NCHRP Report 350* guidelines (1-15). A performance assessment of existing roadside safety devices was performed to help evaluate the impact of adopting the American Association of State Highway and Transportation Officials (AASHTO) *Manual for Assessing Safety Hardware (MASH)* (16). Crash test results, engineering analyses, and engineering judgment were used to assist with the hardware evaluation. Categories of roadside features that were considered under the project include guardrails, median barriers, transitions from approach guardrail to bridge rails, breakaway sign supports, and both precast and permanent concrete barriers. Results of the performance assessment were used to develop a test prioritization scheme for evaluating compliance of selected roadside safety features with the new *MASH* impact performance guidelines (14).

The project panel decided to evaluate the MB4 steel post W-beam median barrier. This system was never crash tested under NCHRP Report 350 guidelines. Rather, the median barrier received FHWA acceptance based on a successful test of the “more critical” G4(1S) steel post guardrail system. Given the marginal performance of the G4(1S) guardrail system when tested following MASH guidelines under NCHRP study 22-14(02), the panel decided that this assumption should be verified through testing.

The additional constraint of the posts imposed by the double-sided G4(1S) W-beam median barrier raised concerns regarding barrier override by the 2270P vehicle and excessive occupant risk when impacted by the small passenger vehicle (1100C). The added post constraint delays release of the post from the rail, which can potentially result in vehicle climb and vaulting due to a localized drop in rail height. The delayed post release can also result in more severe wheel-post interaction and a higher level of occupant risk during the small car impact. Thus, both Test 3-10 and 3-11 were programmed for this median barrier system.

1.2.2 Test Installation Used for Evaluation of 27-Inch MB4 W-Beam Median Barrier

The MB4 W-Beam Median Barrier (AASHTO Designation SGM04a with non-steel blocks) is a 27-inch tall, strong steel post, W-beam median barrier. The median barrier is constructed using 12-gauge W-beam guardrails attached to 6 ft long W6×8.5 steel posts spaced 6 ft-3 inches on center. The W-beam guardrail elements are offset from the posts using non-steel blockouts nominally 6 inches × 8 inches × 14 inches long. Either wood or an FHWA accepted plastic blockout may be used. Wood blockouts were used in the test.

The height of the MB4 W-beam median barrier test installation was 27 inches to the top of the W-beam rail. The length of need for the installation was 100 ft. The median barrier was terminated with ET-PLUS guardrail terminals. The front (impacted) rail was constructed with 37 ft-6 inch long terminals on each end and the rear rail was constructed with 50 ft long terminals on each end. The total overall test installation length was 200 ft.

Figure 1.1 shows a cross section of the MB4 W-beam median barrier. The first test on the median barrier was with the small car (1100C vehicle). The installation was then repaired and used for the test with the pickup (2270P vehicle).

1.2.3 MASH Test 3-10 on 27-Inch G4(1S) W-Beam Median Barrier

The MB4 W-beam median barrier contained and redirected the 1100C vehicle. The vehicle did not penetrate, override, or underide the installation. Maximum dynamic deflection was 11.25 inches. No detached elements, fragments, or other debris were present to penetrate or to show potential for penetrating the occupant compartment, or to present a hazard to others in the area. Maximum occupant compartment deformation was 2.0 inches in the left front driver's area at the level of the floor pan. The 1100C vehicle remained upright during and after the collision event. Maximum roll angle was 8 degrees. Occupant risk factors were within the limits specified in *MASH*. The 1100C vehicle exited the median barrier within the exit box. The G4(1S) W-beam median barrier performed acceptably when impacted by the 1100C vehicle.

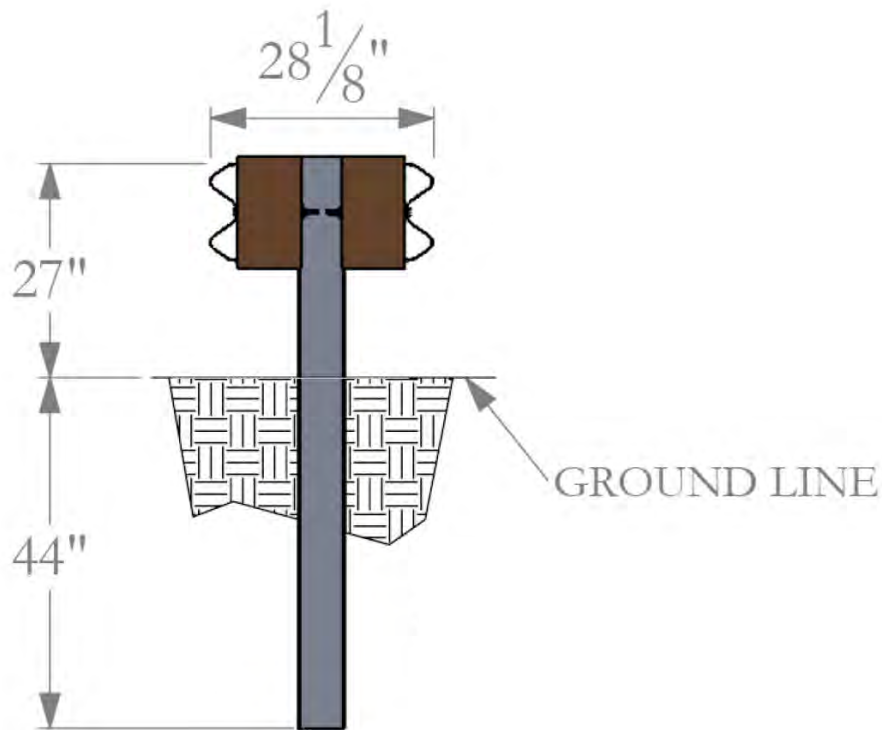

Figure 1.1. Cross Section of the 27-Inch MB4 W-Beam Median Barrier.

1.2.4 MASH Test 3-11 on 27-Inch MB4 W-Beam Median Barrier

The MB4 W-beam median barrier did not contain or redirect the 2270P vehicle. The vehicle overrode the installation. Maximum dynamic deflection of the W-beam during the test was 23.2 inches. The impact speed and angle for this test were 64.0 mi/h and 25.1 degrees, respectively. The impact speed and angle were within the acceptable limits prescribed in *MASH*. However, the impact condition represented an impact severity 15.3 percent greater than the target *MASH* condition (62.2 mi/h and 25 degrees).

The G4(1S) W-beam median barrier did not perform acceptably when impacted by the 2270P vehicle (2007 Chevrolet Silverado pickup). The 2270P Silverado pickup truck overrode the installation.

1.2.5 MASH, FHWA, and the 27-Inch MB4 W-Beam Median Barrier

In a related effort, FHWA released a memorandum pertaining to the height of strong post W-beam guardrail installations (17). In that memorandum, FHWA recommended that state transportation agencies consider adopting a 31-inch tall guardrail system in lieu of the 27-inch high G4(1S) system. The memorandum cited research demonstrating the marginal impact performance of 27-inch high W-beam guardrail systems. Hence, the recommendation was to

adopt one of the 31-inch tall guardrail systems that has successfully passed *MASH* Test Level 3 (TL-3) performance criteria.

1.3 OBJECTIVES/SCOPE OF RESEARCH

This project developed and evaluated a 31-inch tall W-beam median barrier that would meet the strength and safety performance criteria of *MASH* for TL-3 impact conditions.

CHAPTER 2. SIMULATION RESULTS*

To improve the performance of the 27-inch high median W-beam, TTI researchers analyzed the failed test and incorporated design changes that have the potential of rectifying the performance of the W-beam median barrier. First, the research team developed a detailed finite element model of the W-beam median rail to calibrate the model under the *MASH* test previously conducted. The new Silverado vehicle model developed by the National Crash Analysis Center (18) was used to simulate the *MASH* 2270P test vehicle.

In the model, the post was comprised of different thicknesses to accurately represent the shape of a W6×9 steel post. A total of 18,240 shell elements were used for modeling the posts. Additionally, the W-beam model contains a more refined element mesh than the previously used W-beam models, so it can capture deformation more realistically. A total of 182,304 shell elements were used for modeling the W-beam segments (19). Figure 2.1 shows both the post and the W-beam models. The end terminals and the remaining portion of the length-of-need rail were represented by spring elements connected to each end of the modeled W-beam. These springs elements have a combined stiffness representative of typical end terminals.

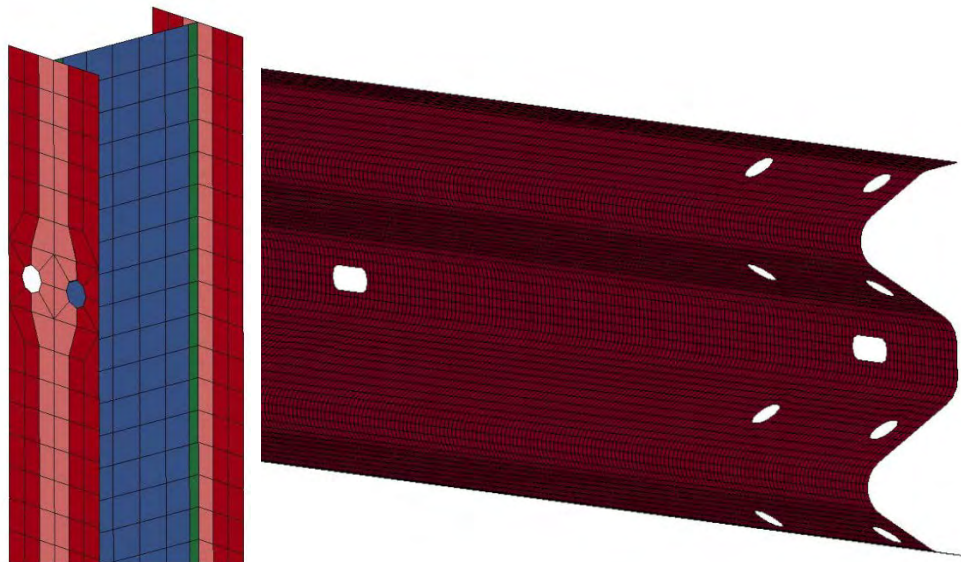

Figure 2.1. Meshing Scheme of the 8-Ft Post Model (Left) and the 12 Gauge W-Beam Rail (Right).

The vehicle model used for simulation was the Chevrolet Silverado model, which was developed by NCAC. This vehicle model represents the *MASH* 2270P test vehicle. The finite element model for the *MASH* 1100C test vehicle was not available at the time this research was performed. Figure 2.2 shows the vehicle and 27-inch median W-beam barrier models.

* TTI Proving Ground's scope of accreditation does not include simulation.

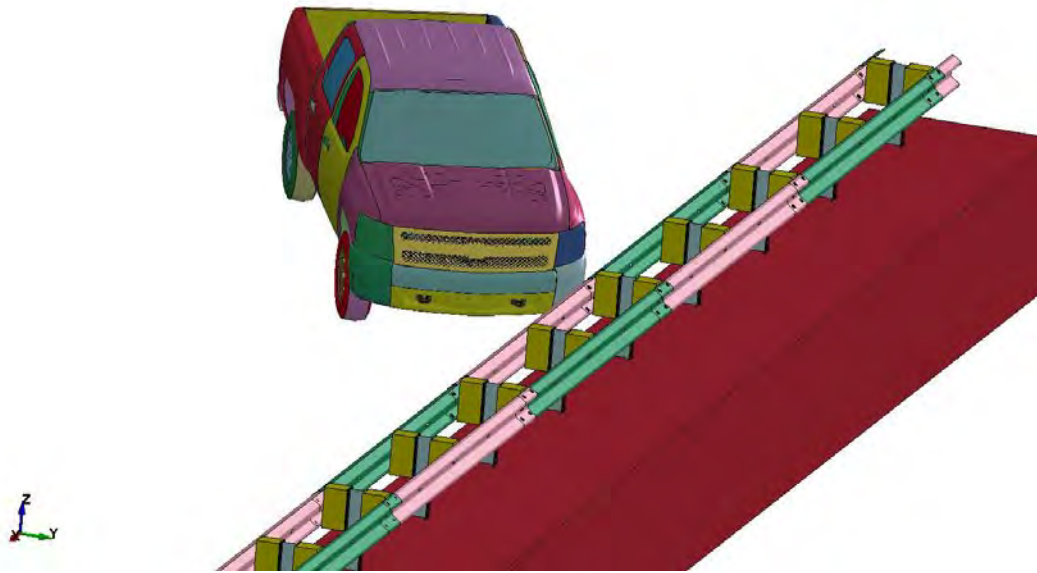

Figure 2.2. Finite Element Model of the 27-Inch Median Barrier.

The research team started by simulating the failed test using LS-DYNA (20) finite element code. Figure 2.3 shows the vaulting phenomena of the vehicle captured in the simulation. Hence, the model is considered corroborated with the failed *MASH* test 3-11 and can be used as a tool to investigate the system performance once modified.



Figure 2.3. Simulation of the *MASH* 3-11 as the 2270P Vehicle Vaults over the 27-Inch Median Barrier.

Design modifications included increasing the rail height from 27 inches to 31 inches and moving the splice location from at-post to mid-span. Figure 2.4 shows the cross-section views of the new system design and the model.

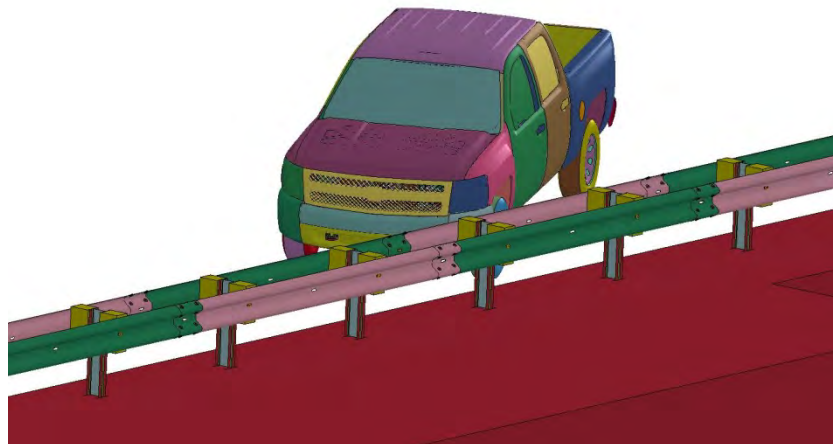

Figure 2.4. Model of the 31-Inch Median W-Beam Guardrail with the 2270P Vehicle Model.

2.1 SIMULATION RESULTS

Two simulations were conducted using LS-DYNA finite element code. One was conducted with vehicular impact at a post and the other with vehicular impact at mid-span between posts.

2.1.1 TL 3-11 Mid-Span Impact

In the first simulation case, the analysis represents vehicular impact at mid-span of the guardrail. The modified barrier system was impacted by 2270P vehicle model at 62.2 mi/h and an angle of 25 degrees. Table 2.1 provides the occupant risk assessments for this model, and vehicle behavior is shown in Figure 2.5.

The Test Risk Assessment Program (TRAP) was used to determine the maximum roll, pitch, and yaw and the specific time that the vehicle reached these values. Figure 2.6 shows the maximum roll was -16.2 degrees at 0.6014 seconds (s). The maximum pitch of the truck was -9.1 degrees at 0.7258 s, and is shown in Figure 2.7. Figure 2.8 shows the maximum yaw of the vehicle was 53.0 degrees at 0.6413 s.

The vehicle exited the system at a speed of 29.97 mi/h at time 0.745 s, and a top view at this point is provided in Figure 2.9. The maximum deflection of the guardrail system was 3.87 ft and occurred at time 0.17 s. Figure 2.10 shows an overhead view of deflection at this point. The contours of plastic strain within the W-beam at the point of maximum deflection are provided in Figure 2.11. Figure 2.12 provides the graph for angular displacements. A summary of results and sequential photos of the run are provided in Figure 2.13.

Table 2.1. TRAP Output Summary for Mid-Span Impact Case.

Occupant Risk Factors			
Impact Velocity (ft/s) at 0.1695 s on left side of interior			
x-direction:	22.0		Rec: <30 ft/s
y-direction:	-15.4		Max: <40 ft/s
THIV (km/h):	26.9	at 0.1633 s on left side of interior	
THIV (m/s):	7.5		
Ridedown Acceleration (Gs)			
x-direction:	-10.6	(0.2471 - 0.2571 s)	Rec: <15 Gs
y-direction:	9.9	(0.2959 - 0.3059 s)	Max: <20 Gs
PHD (Gs):	11.8	(0.2471 - 0.2571 s)	
ASI:	0.78	(0.1477 - 0.1977 s)	
Max. 50-millisecond (ms) Moving Average Acceleration (Gs)			
x-direction:	-7.2	(0.1432 - 0.1932 s)	
y-direction:	4.9	(0.1883 - 0.2383 s)	
z-direction:	2.3	(0.4747 - 0.5247 s)	

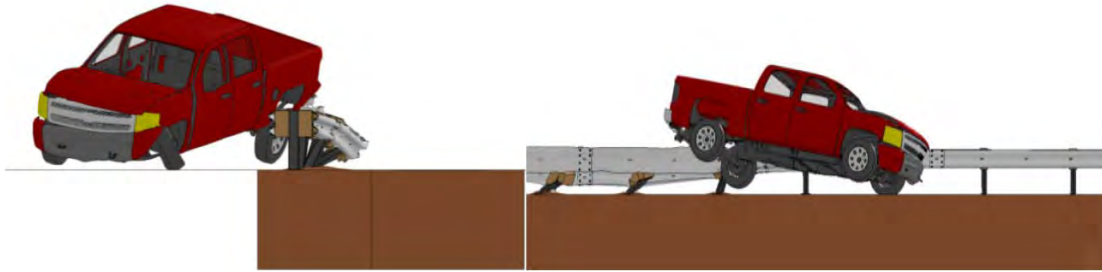

Figure 2.5. Views of Vehicle Behavior for Mid-Span Impact Simulation Case.

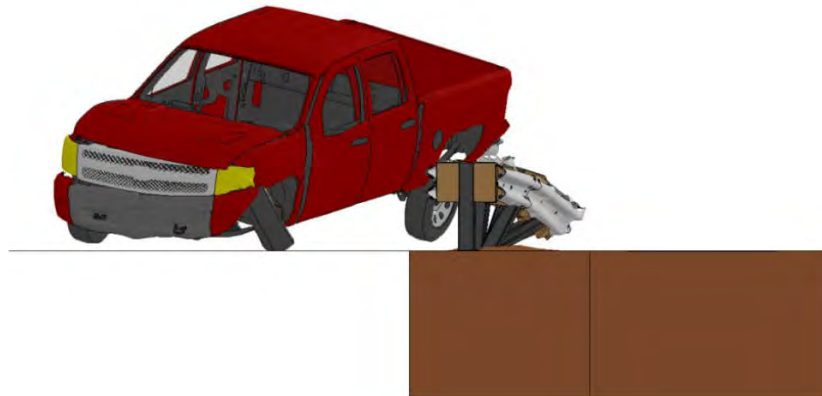

Figure 2.6. Silverado Model at Maximum Roll for Mid-Span Impact.

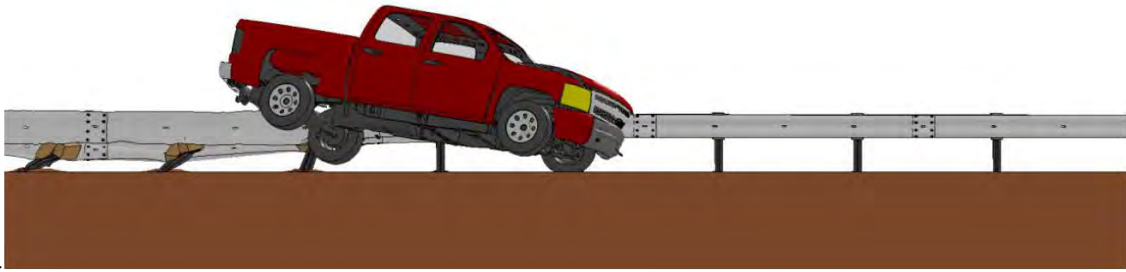

Figure 2.7. Silverado Model at Maximum Pitch for Mid-Span Impact.

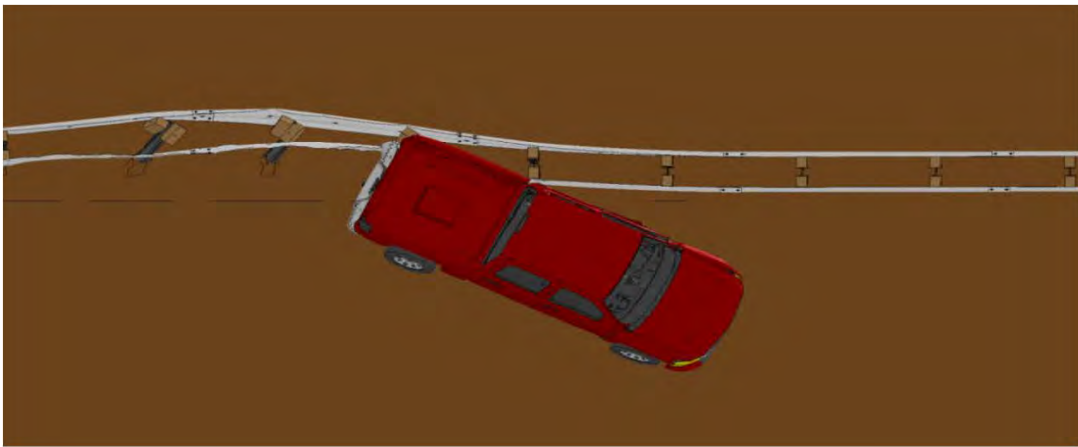

Figure 2.8. Silverado Model at Maximum Yaw for Mid-Span Impact.

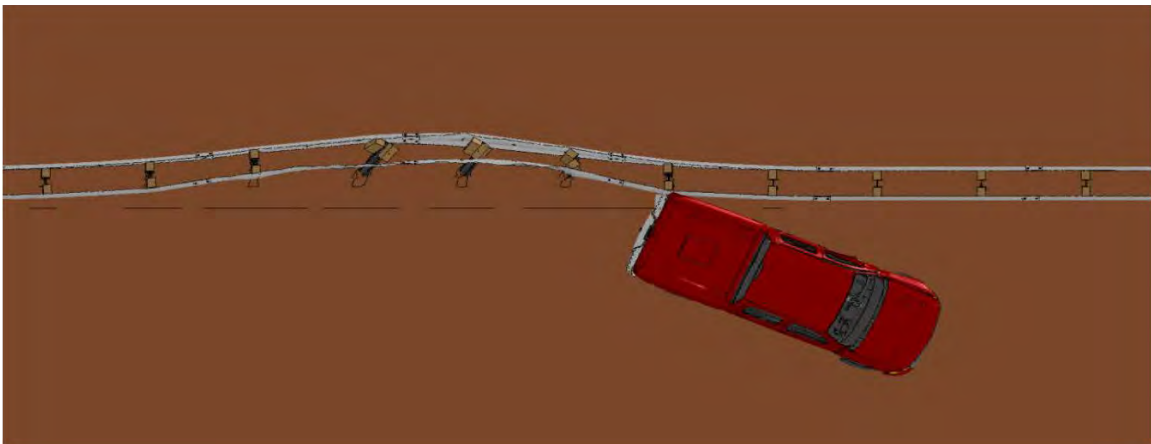
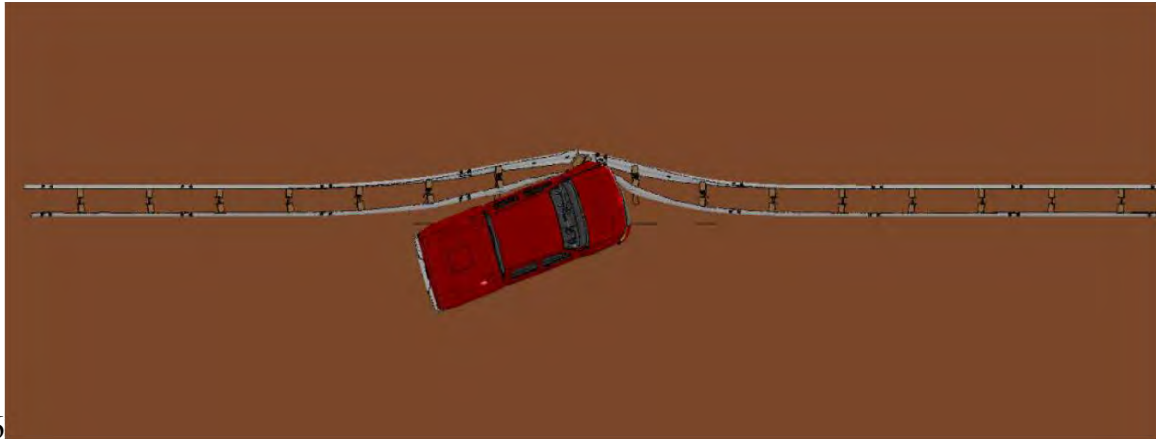

Figure 2.9. Top View of Vehicle Exit for Mid-Span Impact.



6

Figure 2.10. Top View of System's Maximum Deflection for Mid-Span Impact.

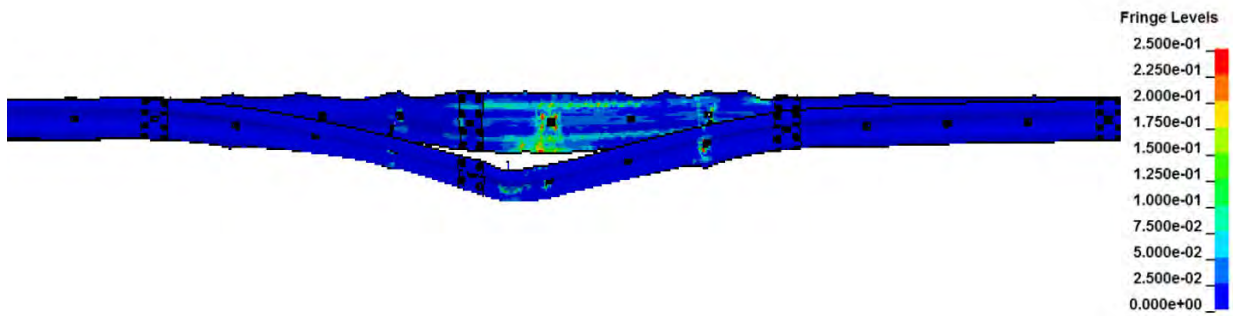

Figure 2.11. Contours of W-Beam Plastic Strain for Mid-Span Impact.

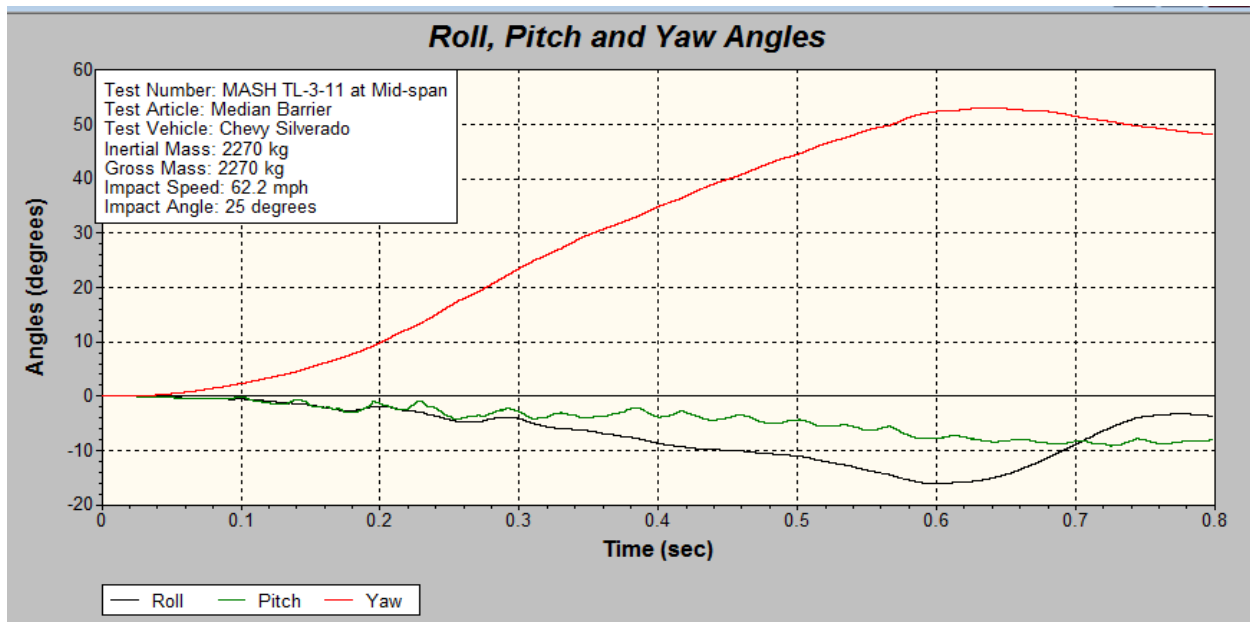
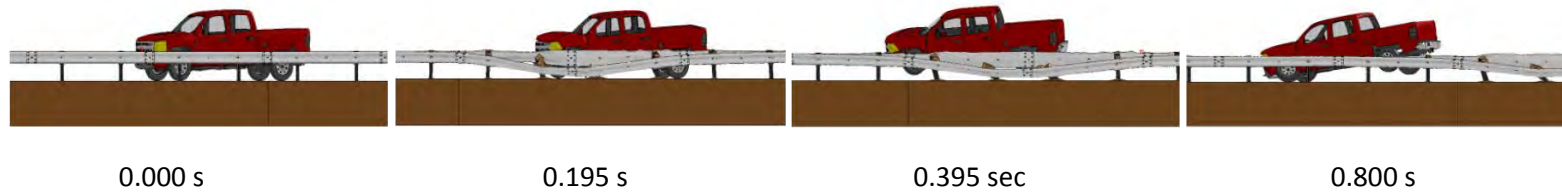

Figure 2.12. Roll, Pitch, and Yaw Angle for Mid-Span Impact.



General Information

Test Agency Texas A&M Transportation Institute (TTI)
 Test Standard Test No. Zephyr - 8673

Test Article

Material or Key Elements Guardrail
 Soil Type and Condition Standard Soil

Test Vehicle

Type/Designation 2270P
 Make and Model..... Chevy Silverado
 Curb 5004 lb
 Test Inertial 5004 lb
 Dummy..... No Dummy
 Gross Static..... 5004 lb

Impact Conditions

Speed 62.2 mi/h
 Angle..... 25 degrees
 Location/Orientation Mid-span

Exit Conditions

Speed.....29.97 mph
 Angle.....

Occupant Risk Values

Impact Velocity
 Longitudinal.....22.0 ft/s
 Lateral-15.4 ft/s
 Ride down Accelerations
 Longitudinal.....-10.6 Gs
 Lateral 9.9 Gs
 THIV 7.5 m/s
 PHD..... 11.8 Gs
 ASI 0.78
 Max. 0.050-s Average
 Longitudinal.....-7.2 Gs
 Lateral 4.9 Gs
 Vertical 2.3 Gs

Vehicle Stability

Maximum Yaw Angle 53.0 degrees
 Maximum Pitch Angle -9.1 degrees
 Maximum Roll Angle -16.2 degrees

Test Article Deflections

Dynamic..... 3.87 ft

Figure 2.13. Summary of Simulation Results for TL 3-11 for Mid-Span Impact.

2.1.2 TL 3-11 At-Post Impact

The modified system was simulated under impact by the 2270P test at a post location, instead of the mid-span, using the same *MASH* TL 3-11 initial conditions of 62.2 mi/h and 25 degrees. Table 2.2 provides the occupant risk assessment for this model, and vehicle behavior is shown in Figure 2.14.

Table 2.2. TRAP Output Summary for At-Post Impact Case.

Occupant Risk Factors			
Impact Velocity (ft/s) at 0.1738 s on left side of interior			
x-direction:	20.0		Rec: <30 ft/s
y-direction:	-15.4		Max: <40 ft/s
THIV (km/hr):	27.1	at 0.1676 s on left side of interior	
THIV (m/s):	7.5		
Ride down Acceleration (Gs)			
x-direction:	-9.5	(0.2046 - 0.2146 s)	Rec: <15 Gs
y-direction:	9.7	(0.2896 - 0.2996 s)	Max: <20 Gs
PHD (G's):	11.8	(0.2046 - 0.2146 s)	
ASI:	0.68	(0.1134 - 0.1634 s)	
Maximum 50-ms Moving Average Acceleration (Gs)			
x-direction:	-6.4	(0.1128 - 0.1628 s)	
y-direction:	5.2	(0.2499 - 0.2999 s)	
z-direction:	3.1	(0.3532 - 0.4032 s)	

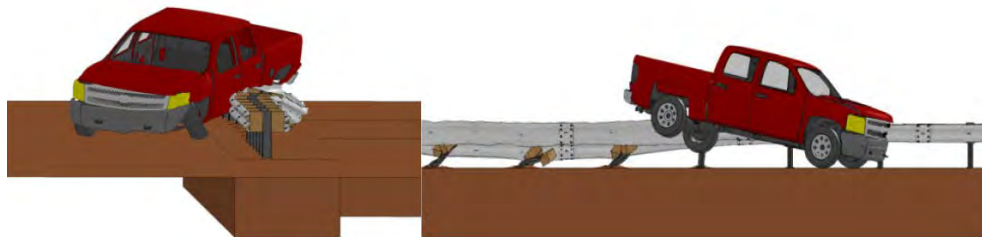

Figure 2.14. Views of Vehicle Behavior for At-Post Impact Simulation Case.

TRAP was used to determine the maximum roll, pitch, and yaw, as well as the specific time the vehicle reached these values. Figure 2.15 shows the maximum roll at -9.1 degrees at 0.4822 s. The maximum pitch of the truck was -9.0 degrees at 0.6507 s, which is provided in Figure 2.16. Figure 2.17 shows the maximum yaw of the vehicle at 51.0 degrees at 0.6084 s.

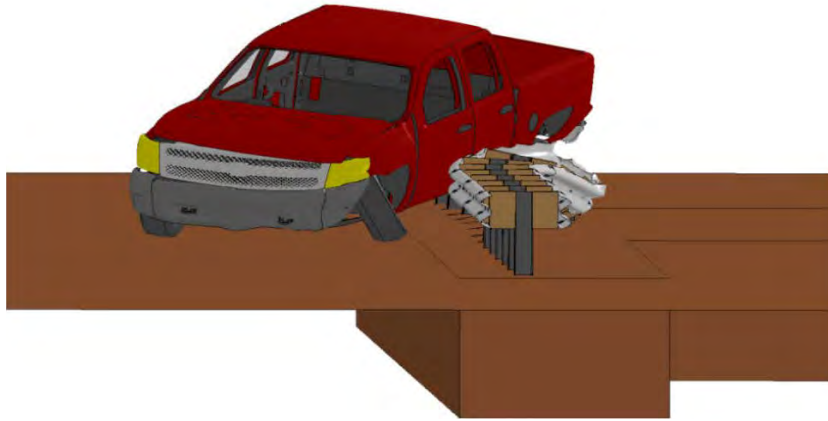

Figure 2.15. Silverado Model at Maximum Roll for At-Post Impact.



Figure 2.16. Silverado Model at Maximum Pitch for At-Post Impact.

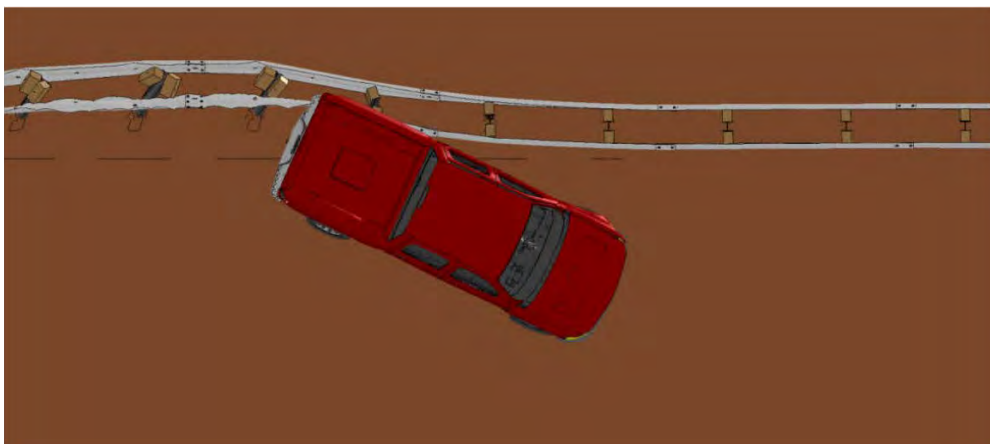

Figure 2.17. Silverado Model at Maximum Yaw for At-Post Impact.

The vehicle exited the system at a speed of 31.09 mi/h at time 0.720 s, and a top view at this point is provided in Figure 2.18. The maximum deflection of the guardrail system was 3.71 ft, and occurred at time 0.12 s. Figure 2.19 shows an overhead view of deflection at this point. The contours of plastic strain within the W-beam at the point of maximum deflection are provided in Figure 2.20.

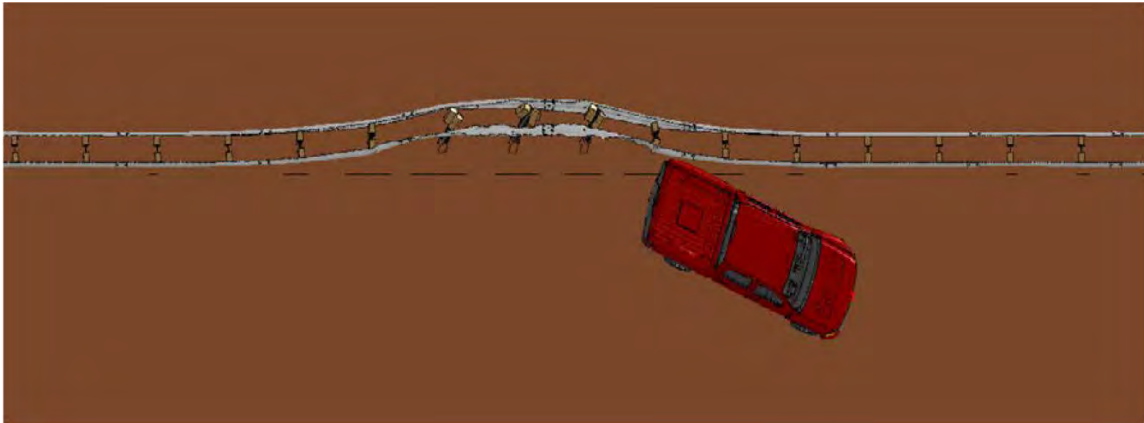

Figure 2.18. Top View of Vehicle Exit for At-Post Impact.

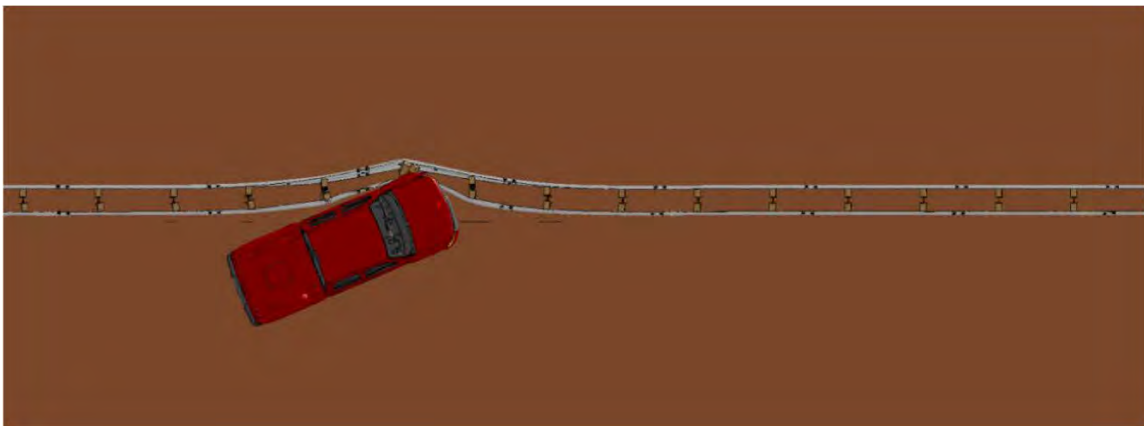

Figure 2.19. Top View of System's Maximum Deflection for At-Post Impact.

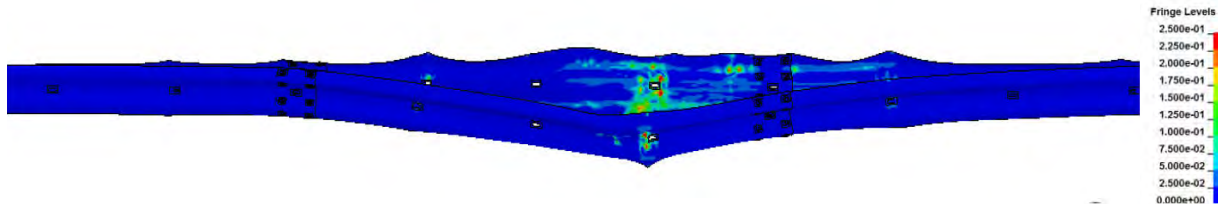

Figure 2.20. Contours of W-Beam Plastic Strain for At-Post Impact.

Figure 2.21 provides the graph for angular displacements. A summary of results and sequential photos for this run are provided in Figure 2.22.

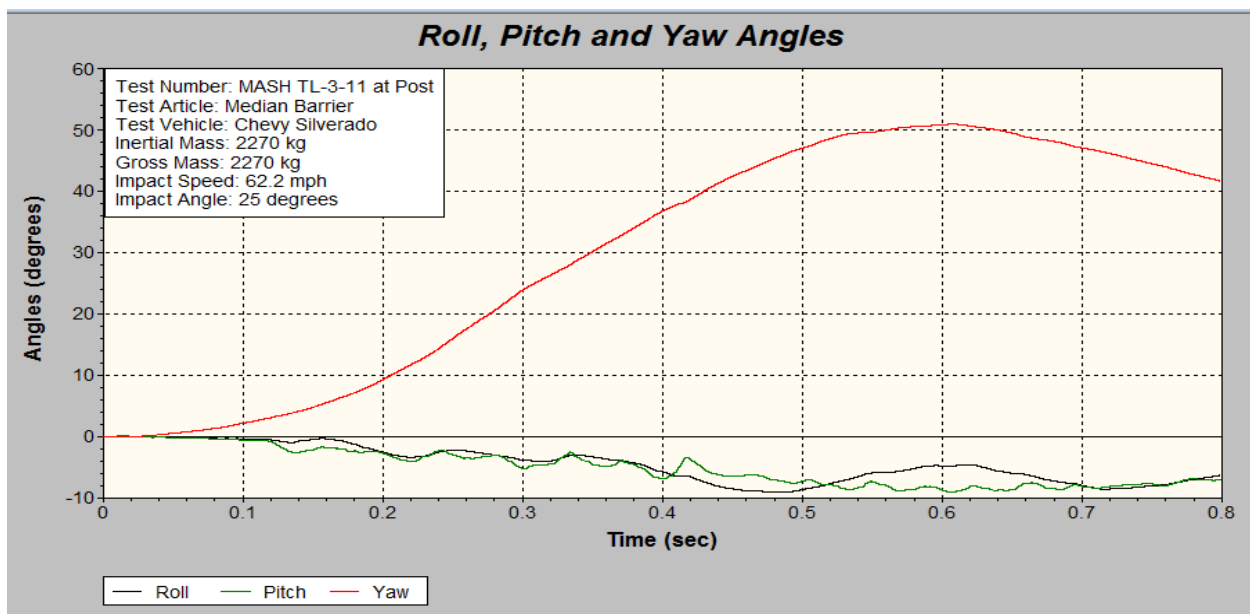
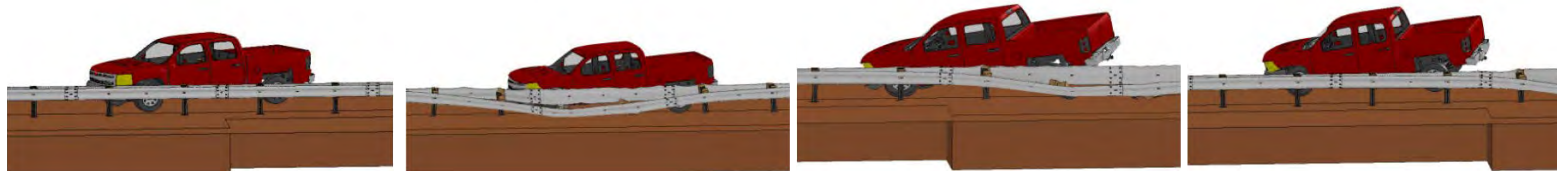

Figure 2.21. Roll, Pitch, and Yaw Angles for At-Post Impact.

2.2 SIMULATION CONCLUSIONS

Both simulation cases indicated that the 31-inch W-beam median barrier is able to contain and redirect the test vehicle, and able to pass *MASH* evaluation criteria presented in Table 2.1 and 2.2. Hence, the research team used the new design for the full-scale crash testing phase of the project.



0.000 sec

0.220 sec

0.520 sec

0.800 sec

General Information

Test Agency Texas A&M Transportation Institute (TTI)
 Test Standard Test No. Zephyr - 8359

Test Article

Material or Key Elements Guardrail
 Soil Type and Condition Standard Soil

Test Vehicle

Type/Designation 2270P
 Make and Model Chevy Silverado
 Curb 5004 lb
 Test Inertial 5004 lb
 Dummy No Dummy
 Gross Static 5004 lb

Impact Conditions

Speed 62.2 mi/h
 Angle 25 degrees
 Location/Orientation At post

Exit Conditions

Speed 31.09 mph
 Angle

Occupant Risk Values

Impact Velocity
 Longitudinal 20.0 ft/s
 Lateral -15.4 ft/s
 Ride down Accelerations
 Longitudinal -9.5 Gs
 Lateral 9.7 Gs
 THIV 7.5 m/s
 PHD 11.5 Gs
 ASI 0.68
 Max. 0.050-s Average
 Longitudinal -6.4 Gs
 Lateral 5.2 Gs
 Vertical 3.1 Gs

Vehicle Stability

Maximum Yaw Angle 51.0 degrees
 Maximum Pitch Angle -9.0 degrees
 Maximum Roll Angle -9.1 degrees
 Vehicle Snagging No
 Vehicle Pocketing No

Test Article Deflections

Dynamic 3.71 ft

Figure 2.22. Summary of Simulation Results for TL-3-11 for At-Post Impact.

CHAPTER 3. SYSTEM DETAILS

3.1 TEST ARTICLE DESIGN AND CONSTRUCTION

The TxDOT W-Beam Median Barrier is a 31-inch tall, strong steel post, W-beam median barrier. The median barrier is constructed using 12-gauge W-beam guardrails attached to 6 ft long W6×8.5 steel posts spaced 6 ft-3 inch on center. The W-beam guardrails are offset from the posts using non-steel blockouts nominally 6 inch × 8 inch × 14 inch long. Either wood or an FHWA accepted plastic blockout may be used. For the tests presented herein, wood blockouts were used. Also, for this installation, the W-beam rail element joints were moved off the posts and centered midspan between posts.

The height of the TxDOT W-Beam Median Barrier test installation was 31 inches. The length of need for the installation was 106 ft. The median barrier was terminated with 25 ft [TREND™](#) guardrail terminals. The TREND™ 350 Median End Terminal is a double-sided, energy-absorbing steel post terminal. The total overall test installation length was 156 ft.

Figures 3.1 and 3.2 provide a layout and cross-section of the TxDOT 31-inch W-Beam Median Barrier. Photographs of the completed installation are shown in Figure 3.3. Appendix A presents more detailed information on the barrier.

3.2 MATERIAL SPECIFICATIONS

Various certification papers and other related material are provided in Appendix B.

3.3 SOIL CONDITIONS

The TxDOT 31-inch W-Beam Median Barrier was installed in standard soil meeting AASHTO standard specifications for “Materials for Aggregate and Sol Aggregate Subbase, Base and Surface Courses,” designated M147-65(2004), grading B.

In accordance with Appendix B of *MASH*, soil strength was measured the day of the crash test (see Appendix C, Tables C1 and C2). During installation of the TxDOT 31-inch W-Beam Median Barrier for full-scale crash testing, two standard W6×16 posts were installed in the immediate vicinity of the TxDOT 31-inch W-Beam Median Barrier test installation, using the same fill materials and installation procedures used in the standard dynamic test (see Appendix C, Table C3).

As determined in the tests shown in Appendix C, Table C3, the minimum post load required for deflections at 5 inches, 10 inches, and 15 inches, measured at a height of 25 inches, is 3940 lb, 5500 lb, and 6540 lb, respectively (90 percent of static load for the initial standard installation). On the day of test no. 490023-3, June 18, 2013, load on the post at deflections of 5 inches, 10 inches, and 15 inches was 7575 lb, 7697 lb, and 7606 lb, respectively (see

Appendix C, Table C1). On the day of test no. 490023-4, June 21, 2013, load on the post at deflections of 5 inches, 10 inches, and 15 inches was 7272 lb, 7303 lb, and 7181 lb, respectively (see Appendix C, Table C2).

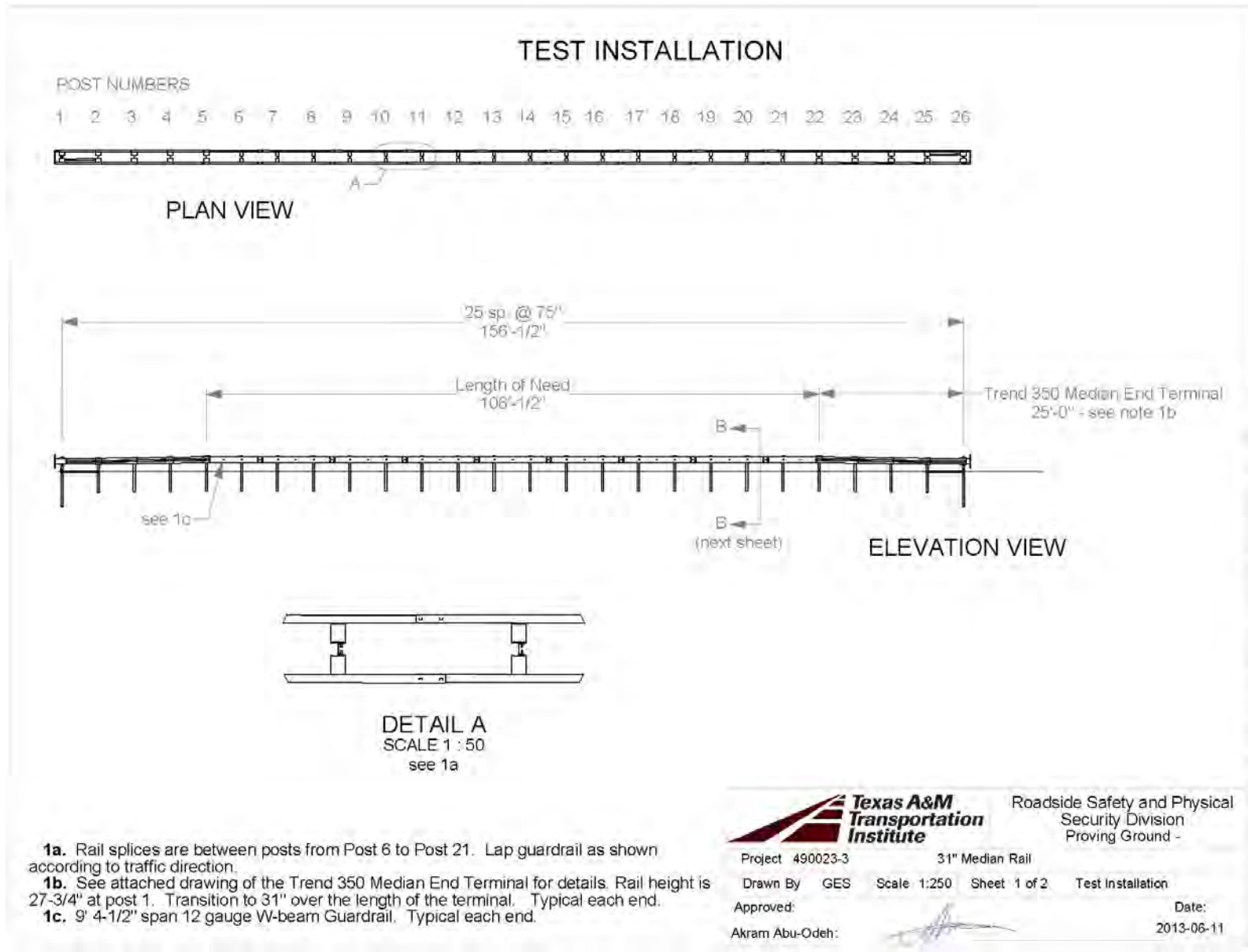

T:\2012-2013\W90023 TxDOT\3 -4 Median Rail\Drafting\2013-06-10\490023-3 Drawing

Figure 3.1. Layout of the TxDOT 31-Inch W-Beam Median Barrier.

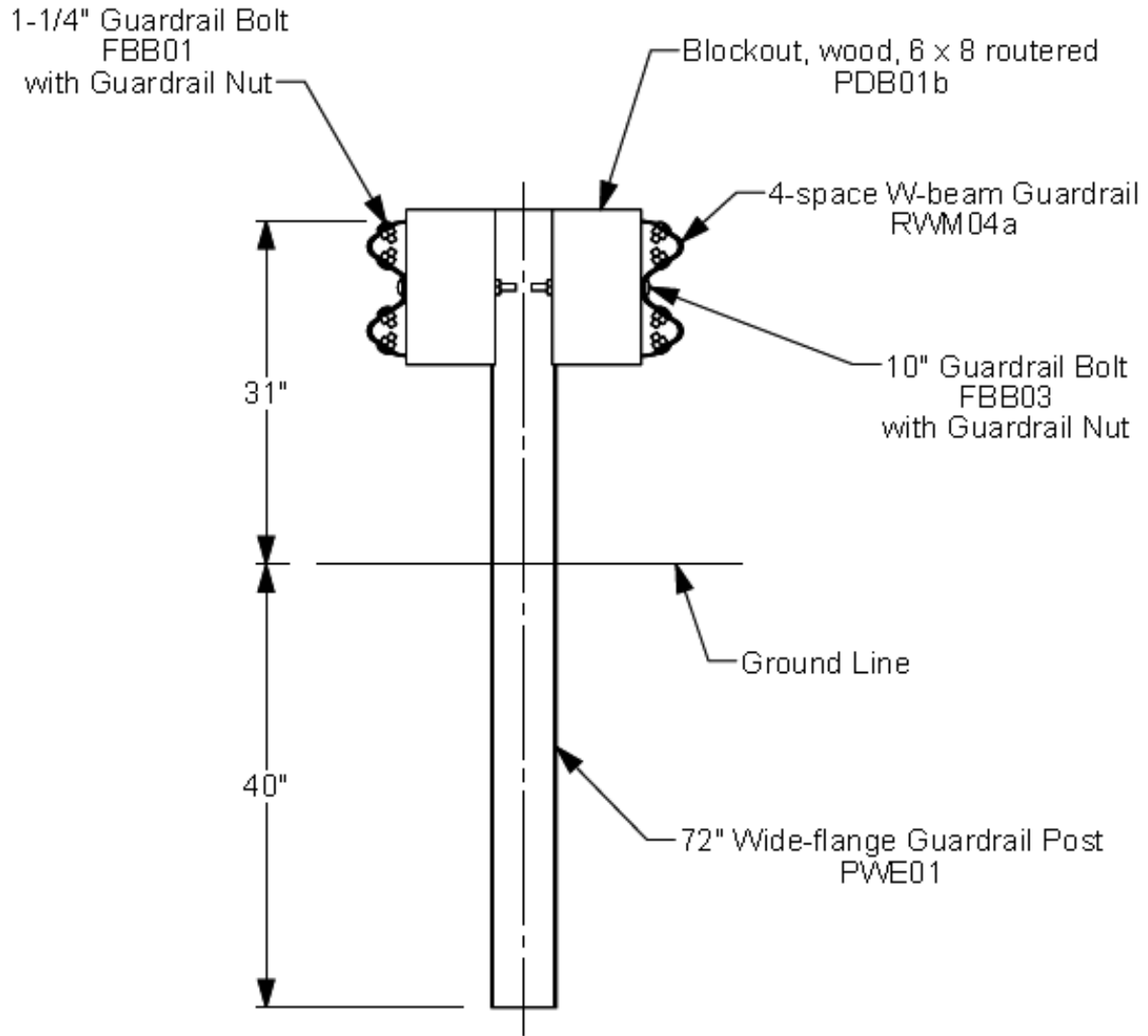

Figure 3.2. Cross-Section of the TxDOT 31-Inch W-Beam Median Barrier.



Figure 3.3. TxDOT 31-Inch W-Beam Median Barrier before Testing.

CHAPTER 4. TEST REQUIREMENTS AND EVALUATION CRITERIA

4.1 CRASH TEST MATRIX

According to *MASH*, two tests are recommended to evaluate longitudinal barriers to test level three (TL-3).

***MASH* Test 3-10:** A 2425-lb vehicle impacting the critical impact point (CIP) of the length of need (LON) of the barrier at a nominal impact speed and angle of 62 mi/h and 25 degrees, respectively. This test investigates a barrier's ability to successfully contain and redirect a small passenger vehicle.

***MASH* Test 3-11:** A 5000-lb pickup truck impacting the CIP of the LON of the barrier at a nominal impact speed and angle of 62 mi/h and 25 degrees, respectively. This test investigates a barrier's ability to successfully contain and redirect light trucks and sport utility vehicles.

Both above listed tests were performed on the TxDOT 31-inch W-Beam Median Barrier. Procedures in *MASH* section 2.3.2.1 were used by the research team to calculate the CIP for each test. Target CIPs were 7.95 ft upstream of post 13 for *MASH* test 3-10 (Test No. 490023-3), and 10.5 ft upstream of post 13 for *MASH* test 3-11 (Test No. 490023-4).

The crash test and data analysis procedures were in accordance with guidelines presented in *MASH*. Chapter 5 presents brief descriptions of these procedures.

4.2 EVALUATION CRITERIA

The crash tests were evaluated in accordance with the criteria presented in *MASH*. The performance of the TxDOT 31-inch W-Beam Median Barrier is judged on the basis of three factors: structural adequacy, occupant risk, and post impact vehicle trajectory. Structural adequacy is judged upon the ability of the TxDOT 31-inch W-Beam Median Barrier to contain and redirect the vehicle, or bring the vehicle to a controlled stop in a predictable manner. Occupant risk criteria evaluate the potential risk of hazard to occupants in the impacting vehicle, and, to some extent, other traffic, pedestrians, or workers in construction zones, if applicable. Post-impact vehicle trajectory is assessed to determine potential for secondary impact with other vehicles or fixed objects, creating further risk of injury to occupants of the impacting vehicle and/or risk of injury to occupants in other vehicles. The appropriate safety evaluation criteria from Table 5-1 of *MASH* were used to evaluate the crash test reported here, and are listed in further detail under the assessment of the crash test.

CHAPTER 5. CRASH TEST PROCEDURES

5.1 TEST FACILITY

The full-scale crash tests reported here were performed at Texas A&M Transportation Institute Proving Ground, an International Standards Organization (ISO) 17025 accredited laboratory with American Association for Laboratory Accreditation (A2LA) Mechanical Testing certificate 2821.01. The full-scale crash test was performed according to TTI Proving Ground quality procedures and according to the *MASH* guidelines and standards.

The Texas A&M Transportation Institute Proving Ground is a 2000-acre complex of research and training facilities located 10 miles northwest of the main campus of Texas A&M University. The site, formerly an Air Force base, has large expanses of concrete runways and parking aprons well-suited for experimental research and testing in the areas of vehicle performance and handling, vehicle-roadway interaction, durability and efficacy of highway pavements, and safety evaluation of roadside safety hardware. The site selected for construction and testing of the TxDOT 31-inch W-Beam Median Barrier evaluated under this project was along the edge of an out-of-service apron. The apron consists of an unreinforced jointed-concrete pavement in 12.5 ft × 15 ft blocks nominally 6 inches deep. The apron is over 60 years old, and the joints have some displacement, but are otherwise flat and level.

5.2 VEHICLE TOW AND GUIDANCE PROCEDURES

The test vehicles were towed into the test installation using a steel cable guidance and reverse tow system. A steel cable for guiding the test vehicle was tensioned along the path, anchored at each end, and threaded through an attachment to the front wheel of the test vehicle. An additional steel cable was connected to the test vehicle, passed around a pulley near the impact point, through a pulley on the tow vehicle, and then anchored to the ground such that the tow vehicle moved away from the test site. A two-to-one speed ratio between the test and tow vehicle existed with this system. Just prior to impact with the installation, the test vehicle was released to be unrestrained. The vehicle remained free-wheeling (i.e., no steering or braking inputs) until it cleared the immediate area of the test site, after which the brakes can be activated, if necessary, to bring it to a safe and controlled stop.

5.3 DATA ACQUISITION SYSTEMS

5.3.1 Vehicle Instrumentation and Data Processing

The test vehicles were instrumented with a self-contained, on-board data acquisition system. The signal conditioning and acquisition system is a 16-channel, Tiny Data Acquisition System (TDAS) Pro produced by Diversified Technical Systems, Inc. The accelerometers, that measure the x, y, and z axis of vehicle acceleration, are strain gauge type with linear millivolt output proportional to acceleration. Angular rate sensors, measuring vehicle roll, pitch, and yaw rates, are ultra small size, solid state units designed for crash test service. The TDAS Pro hardware and software conform to the latest SAE J211, Instrumentation for Impact Test. Each of

the 16 channels is capable of providing precision amplification, scaling and filtering based on transducer specifications and calibrations. During the test, data are recorded from each channel at a rate of 10,000 values per second with a resolution of one part in 65,536. Once recorded, the data are backed up inside the unit by internal batteries should the primary battery cable be severed. Initial contact of the pressure switch on the vehicle bumper provides a time zero mark as well as initiating the recording process. After each test, the data are downloaded from the TDAS Pro unit into a laptop computer at the test site. The raw data are then processed by the Test Risk Assessment Program (TRAP) software to produce detailed reports of the test results. Each of the TDAS Pro units is returned to the factory annually for complete recalibration. Accelerometers and rate transducers are also calibrated annually with traceability to the National Institute for Standards and Technology. Acceleration data are measured with an expanded uncertainty of ± 1.7 percent at a confidence factor of 95 percent ($k=2$).

TRAP uses the data from the TDAS Pro to compute occupant/compartiment impact velocities, time of occupant/compartiment impact after vehicle impact, and the highest 10-millisecond (ms) average ridedown acceleration. TRAP calculates change in vehicle velocity at the end of a given impulse period. In addition, maximum average accelerations over 50-ms intervals in each of the three directions are computed. For reporting purposes, the data from the vehicle-mounted accelerometers are filtered with a 60-Hz digital filter, and acceleration versus time curves for the longitudinal, lateral, and vertical directions are plotted using TRAP.

TRAP uses the data from the yaw, pitch, and roll rate transducers to compute angular displacement in degrees at 0.0001-s intervals and then plots yaw, pitch, and roll versus time. These displacements are in reference to the vehicle-fixed coordinate system with the initial position and orientation of the vehicle-fixed coordinate systems being initial impact. Rate of rotation data is measured with an expanded uncertainty of ± 0.7 percent at a confidence factor of 95 percent ($k=2$).

5.3.2 Anthropomorphic Dummy Instrumentation

An Alderson Research Laboratories Hybrid II, 50th percentile male anthropomorphic dummy, restrained with lap and shoulder belts, was placed in the driver's position of the 1100C vehicle. The dummy was uninstrumented. Use of a dummy in the 2270P vehicle is optional according to *MASH*, and no dummy was used in the tests with the 2270P vehicle.

5.3.3 Photographic Instrumentation and Data Processing

Photographic coverage of the test included three high-speed cameras: one overhead with a field of view perpendicular to the ground and directly over the impact point; one placed behind the installation at an angle; and a third placed to have a field of view parallel to and aligned with the installation at the downstream end. A flashbulb activated by pressure-sensitive tape switches was positioned on the impacting vehicle to indicate the instant of contact with the installation and was visible from each camera. The films from these high-speed cameras were analyzed on a computer-linked motion analyzer to observe phenomena occurring during the collision and to obtain time-event, displacement, and angular data. A mini-DV camera and still cameras recorded and documented conditions of the test vehicle and installation before and after the test.

CHAPTER 6. CRASH TEST RESULTS FOR *MASH* TEST 3-10

6.1 TEST DESIGNATION AND ACTUAL IMPACT CONDITIONS

MASH test 3-10 involves an 1100C vehicle weighing 2420 lb \pm 55 lb and impacting the TxDOT 31-inch W-Beam Median Barrier at an impact speed of 62.2 mi/h \pm 2.5 mi/h and an angle of 25 degrees \pm 1.5 degrees. The target impact point was 21 inches upstream of post 12. The 2006 Kia Rio used in the test weighed 2444 lb, and the actual impact speed and angle were 62.2 mi/h and 25.0 degrees, respectively. The actual impact point was 22 inches upstream of post 12. Target impact severity (IS) was 55.7 kip-ft, and actual IS was 56.5 kip-ft.

6.2 TEST VEHICLE

A 2006 Kia Rio, shown in Figures 4 and 5, was used for the crash test. Test inertia weight of the vehicle was 2444 lb, and its gross static weight was 2624 lb. The height to the lower edge of the vehicle bumper was 7.12 inches, and it was 21.00 inches to the upper edge of the bumper. Tables D1 and D2 in Appendix D give additional dimensions and information on the vehicle. The vehicle was directed into the installation using the cable reverse tow and guidance system, and was released to be free-wheeling and unrestrained just prior to impact.

6.3 WEATHER CONDITIONS

The test was performed on the morning of June 18, 2013. Weather conditions at the time of testing were as follows: wind speed: 6 mi/h; wind direction: 355 degrees with respect to the vehicle (vehicle was traveling in a northwesterly direction); temperature: 84°F, relative humidity: 72 percent.

6.4 TEST DESCRIPTION

The 2006 Kia Rio, traveling at an impact speed of 62.2 mi/h, impacted the TxDOT 31-inch W-Beam Median Barrier 22 inches upstream of post 12 at an impact angle of 25.0 degrees. At approximately 0.013 s, post 12 began to deflect toward the side opposite impact, and at 0.034 s, the left front tire contacted post 12. The W-beam on the side opposite impact began to deflect toward the side opposite impact at 0.035 s, and the vehicle began to redirect at 0.037 s. At 0.062 s, the left front tire contacted post 13, and at 0.149 s, the blockouts at post 13 separated from the post and rail element. The vehicle began traveling parallel with the installation at 0.343 s. At 0.488 s, the vehicle lost contact with the installation, however, the overhead camera failed and exit speed and angle were not attainable. Brakes on the 1100C vehicle were applied at 2.5 s after impact, the vehicle yawed counterclockwise 180 degrees and came to rest 153.3 ft downstream of impact. Figures D1 and D2 in Appendix D show sequential photographs of the test period.



Figure 6.1. Vehicle/Installation Geometrics for Test No. 490023-3.



Figure 6.2. Vehicle before Test No. 490023-3.

6.5 DAMAGE TO TEST INSTALLATION

Figures 6.3 and 6.4 show damage to the TxDOT 31-inch W-Beam Median Barrier. No apparent movement was noted at post 1 or post 26 (the end posts). Post 11 and 12 were displaced through the soil toward the side opposite impact 0.25 inch and 1.75 inches, respectively. Posts 13 and 14 were leaning 70 degrees toward the side opposite impact and the rail element on the impact side separated from the posts. Both blockouts at post 13 separated from the post and the blockout on the side opposite impact separated from post 14. Post 15 rotated 45 degrees in the soil, the blockout on impact side separated from the post, and both rail elements separated from the post. The rail element on the impact side ruptured upward two-thirds of the width of the rail element at the upstream bolts on the splice between posts 12 and 13. The length of contact of the 1100C vehicle with the rail was 22.0 ft. Maximum permanent deformation of the rail was 20.25 inches between posts 13 and 14.

6.6 VEHICLE DAMAGE

Figure 6.5 shows damage to the 1100C vehicle. The front bumper, hood, radiator and support, left front strut and tower, left front tire and wheel rim, left front fender, and left front door were damaged. The hood was pushed into the windshield, which shattered the lower portion of the windshield. Maximum exterior crush to the 1100C vehicle was 13.0 inches in the side plane at the left front corner just above bumper height. No occupant compartment deformation was noted. Figure 6.6 provides photographs of the interior of the vehicle, and Tables D1 and D2 provide exterior and occupant compartment measurements.

6.7 OCCUPANT RISK FACTORS

Data from the accelerometer, located at the vehicle center of gravity, were digitized for evaluation of occupant risk. In the longitudinal direction, the occupant impact velocity was 20.0 ft/s at 0.115 s, the highest 0.010-s occupant ridedown acceleration was 9.6 Gs from 0.172 to 0.182 s, and the maximum 0.050-s average acceleration was -7.3 Gs between 0.076 and 0.126 s. In the lateral direction, the occupant impact velocity was 17.4 ft/s at 0.115 s, the highest 0.010-s occupant ridedown acceleration was 8.3 Gs from 0.155 to 0.165 s, and the maximum 0.050-s average was 6.9 Gs between 0.038 and 0.088s. Theoretical Head Impact Velocity (THIV) was 28.0 km/h or 7.8 m/s at 0.111 s; Post-Impact Head Decelerations (PHD) was 11.0 Gs between 0.172 and 0.182 s; and Acceleration Severity Index (ASI) was 0.94 between 0.038 and 0.088 s. These data and other pertinent information from the test are summarized in Figure 6.7. Vehicle angular displacements and accelerations versus time traces are presented in Appendix D, Figures D3 through D9.



Figure 6.3. Vehicle/Installation Positions after Test No. 490023-3.

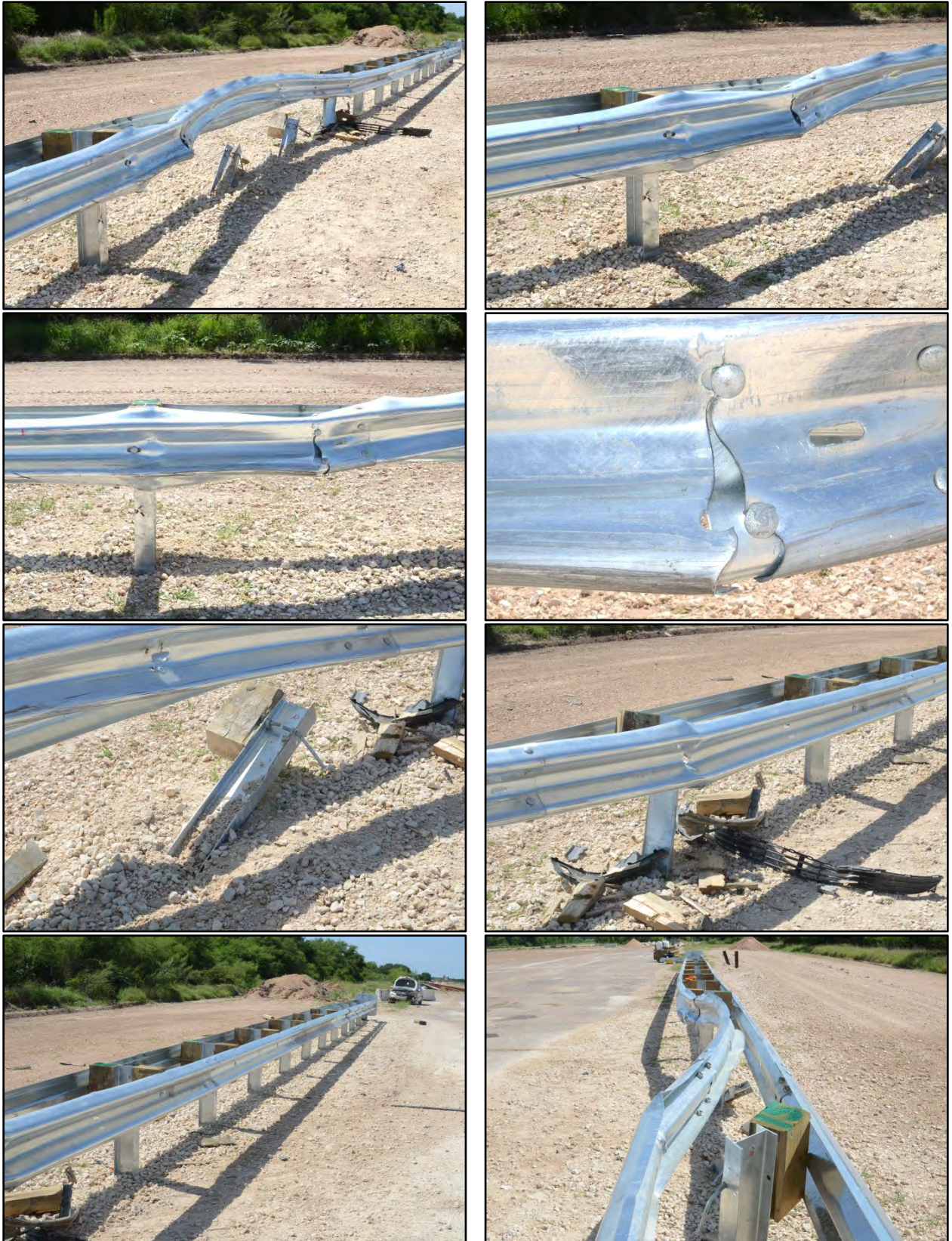

Figure 6.4. Installation after Test No. 490023-3.



Figure 6.5. Vehicle after Test No. 490023-3.



Figure 6.6. Interior of Vehicle for Test No. 490023-3.

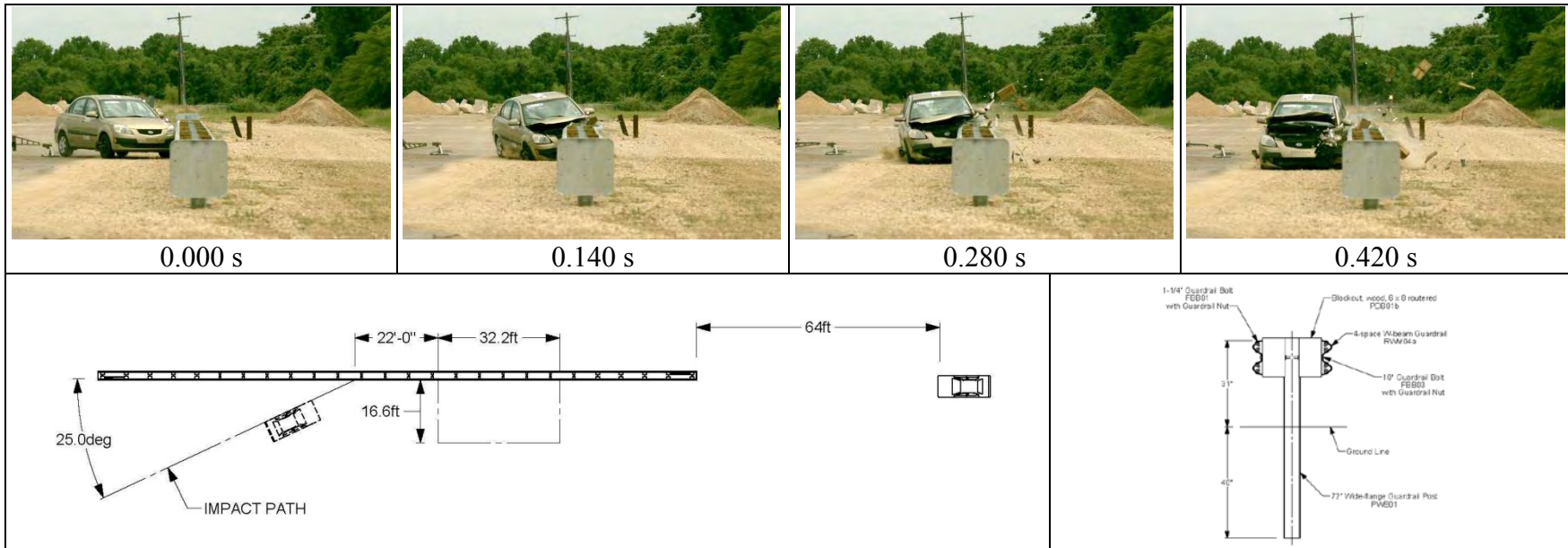

General Information

Test Agency Texas A&M Transportation Institute (TTI)
 Test Standard Test No. MASH Test 3-10
 TTI Test No. 490023-3
 Test Date 2013-06-18

Test Article

Type Median Barrier
 Name TxDOT 31-inch W-Beam Median Barrier
 Installation Length 156 ft
 Material or Key Elements 12-gauge W-beam at 31 inch height on 6 ft long W6x8.5 steel posts spaced 6 ft-3 inch on center with 6 inch x 8 inch x 14 inch routed wood blockouts with splice midspan between posts

Soil Type and Condition..... Standard soil, dry

Test Vehicle

Type/Designation 1100C
 Make and Model..... 2006 Kia Rio
 Curb 2494 lb
 Test Inertial 2444 lb
 Dummy..... 180 lb
 Gross Static..... 2624 lb

Impact Conditions

Speed.....62.2 mi/h
 Angle.....25.0 degrees
 Location/Orientation27 inches upstrm of post 12
 Impact Severity.....56.5 kip-ft

Exit Conditions

Speed.....Not obtainable
 Angle.....Not obtainable

Occupant Risk Values

Impact Velocity
 Longitudinal.....20.0 ft/s
 Lateral17.4 ft/s
 Ridedown Accelerations
 Longitudinal9.6 G
 Lateral8.3 G
 THIV.....7.8 m/s
 PHD11.0 G
 ASI0.94
 Max. 0.050-s Average
 Longitudinal.....-7.3 G
 Lateral6.9 G
 Vertical.....-3.0 G

Post-Impact Trajectory

Stopping Distance 132.5 ft dwnstrm
 Aligned w/cntr rail

Vehicle Stability

Maximum Yaw Angle..... 36 degrees
 Maximum Pitch Angle..... 9 degrees
 Maximum Roll Angle..... 11 degrees
 Vehicle Snagging..... No
 Vehicle Pocketing Yes/No

Test Article Deflections

Dynamic 25.4 inches
 Permanent..... 20.25 inches
 Working Width 33.6 inches
 Vehicle Intrusion..... 21.5 inches

Vehicle Damage

VDS..... 11KFQ5
 CDC 11FLEW 4
 Max. Exterior Deformation 13.0 inches
 OCDI LF0000000
 Max. Occupant Compartment Deformation..... None

Figure 6.7. Summary of Results for MASH Test 3-10 on the TxDOT 31-Inch W-Beam Median Barrier.

6.1 ASSESSMENT OF TEST RESULTS

An assessment of the test based on the applicable *MASH* safety evaluation criteria is provided below.

6.1.1 Structural Adequacy

- A. *Test article should contain and redirect the vehicle or bring the vehicle to a controlled stop; the vehicle should not penetrate, underride, or override the installation although controlled lateral deflection of the test article is acceptable.*

Results: The TxDOT 31-inch W-Beam Median Barrier contained and redirected the 1100C vehicle. The vehicle did not penetrate, underride, or override the installation. Maximum dynamic deflection during the test was 25.4 inches. (PASS)

6.1.2 Occupant Risk

- D. *Detached elements, fragments, or other debris from the test article should not penetrate or show potential for penetrating the occupant compartment, or present an undue hazard to other traffic, pedestrians, or personnel in a work zone.*

Deformation of, or intrusions into, the occupant compartment should not exceed limits set forth in Section 5.3 and Appendix E of MASH (roof ≤ 4.0 inches; windshield = ≤ 3.0 inches; side windows = no shattering by test article structural member; wheel/foot well/toe pan ≤ 9.0 inches; forward of A-pillar ≤ 12.0 inches; front side door area above seat ≤ 9.0 inches; front side door below seat ≤ 12.0 inches; floor pan/transmission tunnel area ≤ 12.0 inches).

Results: Three blockouts separated from posts. One blockout split apart and came to rest beneath the rail; one blockout came to rest 15 ft toward the opposite side of impact; and the third came to rest 10 ft toward traffic lanes. These blockouts did not penetrate or show potential for penetrating the occupant compartment. (PASS)

No occupant compartment deformation occurred. (PASS)

- F. *The vehicle should remain upright during and after collision. The maximum roll and pitch angles are not to exceed 75 degrees.*

Results: The 1100C vehicle remained upright during and after the collision event. Maximum roll and pitch angles during the test were 11 degrees and 9 degrees, respectively. (PASS)

H. *Occupant impact velocities should satisfy the following:*
Longitudinal and Lateral Occupant Impact Velocity

<u>Preferred</u>	<u>Maximum</u>
30 ft/s	40 ft/s

Results: Longitudinal occupant impact velocity was 20.0 ft/s, and lateral occupant impact velocity was 17.4 ft/s. (PASS)

I. *Occupant ridedown accelerations should satisfy the following:*
Longitudinal and Lateral Occupant Ridedown Accelerations

<u>Preferred</u>	<u>Maximum</u>
15.0 Gs	20.49 Gs

Results: Longitudinal ridedown acceleration was 9.6 G, and lateral ridedown acceleration was 8.3 G. (PASS)

6.1.3 Vehicle Trajectory

For redirective devices, the vehicle shall exit the barrier within the exit box (not less than 32.8 ft).

Result: The 1100C vehicle exited within the criteria specified above. (PASS)

CHAPTER 7. CRASH TEST RESULTS FOR *MASH* TEST 3-11

7.1 TEST DESIGNATION AND ACTUAL IMPACT CONDITIONS

MASH test 3-11 involves a 2270P vehicle weighing 5000 lb \pm 110 lb and impacting the TxDOT 31-inch W-Beam Median Barrier at an impact speed of 62.2 mi/h \pm 2.5 mi/h and an angle of 25 degrees \pm 1.5 degrees. The target impact point was 10.5 ft upstream of post 13. The 2007 Dodge Ram 1500 pickup truck used in the test weighed 5017 lb and the actual impact speed and angle were 63.0 mi/h and 25.4 degrees, respectively. The actual impact point was 10.8 ft upstream of post 13. Target impact severity (IS) was 115.1 kip-ft, and actual IS was 122.5 kip-ft.

7.2 TEST VEHICLE

A 2007 Dodge Ram 1500 pickup truck, shown in Figures 7.1 and 7.2, was used for the crash test. Test inertia weight of the vehicle was 5014 lb, and its gross static weight was 5017 lb. The height to the lower edge of the vehicle bumper was 15.50 inches, and it was 28.00 inches to the upper edge of the bumper. The height to the vehicle's center of gravity was 28.50 inches. Tables E1 and E2 in Appendix E give additional dimensions and information on the vehicle. The vehicle was directed into the installation using the cable reverse tow and guidance system, and was released to be free-wheeling and unrestrained just prior to impact.

7.3 WEATHER CONDITIONS

The test was performed on the morning of June 21, 2013. Weather conditions at the time of testing were as follows: wind speed: 9 mi/h; wind direction: 173 degrees with respect to the vehicle (vehicle was traveling in a northwesterly direction); temperature: 87°F; relative humidity: 65 percent.

7.4 TEST DESCRIPTION

The 2007 Dodge Ram 1500 pickup truck, traveling at an impact speed of 63.0 mi/h, impacted the TxDOT 31-inch W-Beam Median Barrier 10.8 ft upstream of post 13 at an impact angle of 25.4 degrees. At approximately 0.034 s after impact, the 2270P vehicle began to redirect, and at 0.035 s, the rail element on the side opposite impact began to deform toward the side opposite impact. The left front corner of the vehicle contacted post 13 at 0.057 s, and the vehicle began traveling parallel with the installation at 0.289 s. At 0.691 s, the 2270P vehicle lost contact with the installation, however, was out of view of the overhead camera and exit speed and angle were not obtainable. Brakes on the vehicle were applied at 2.4 s after impact, and the vehicle yawed counterclockwise 136 degrees and came to rest 119.5 ft downstream of impact. Figures E1 and E2 in Appendix E show sequential photographs of the test period.



Figure 7.1. Vehicle/Installation Geometrics for Test No. 490023-4.



Figure 7.2. Vehicle before Test No. 490023-4.

7.5 DAMAGE TO TEST INSTALLATION

Figures 7.3 and 7.4 show damage to the TxDOT 31-inch W-Beam Median Barrier. Post 1 was displaced through the soil 0.5 inch at ground level on the upstream side, and no apparent movement was noted at post 26 (end posts). Posts 6 through 11 were slightly rotated, and post 11 was displaced through the soil 0.5 inch toward the side opposite impact. Post 12 was leaning downstream and toward the side opposite impact 45 degrees. Post 13 was leaning downstream 85 degrees and toward the side opposite impact 45 degrees. Posts 14 and 15 were leaning downstream 60 degrees. Post 16 was rotated slightly. The rail element on the impact side separated from posts 12 through 15, and the rail element on the side opposite impact released from posts 8 through 17. The blockouts on the impact side of posts 12 through 15 fractured and separated from the posts and rail element. The length of contact of the 2270P vehicle with the rail was 31.0 ft. Maximum permanent deformation of the rail was 29.5 inches between posts 13 and 14.

7.6 VEHICLE DAMAGE

Figure 7.5 shows damage to the 2270P vehicle. The left front tie rod, left front lower A-arm, left front frame rail, and left front hub assembly were deformed. Also damaged were the front bumper, grill, left front tire and wheel rim, left front fender, left front door, left rear door, left rear exterior bed, left rear tire, and rear bumper. Maximum exterior crush to the vehicle was 11.0 inches in the side plane at the left front corner just above bumper height. No occupant compartment deformation occurred. Figure 7.6 shows the interior of the vehicle before and after the test. Tables E3 and E3 in Appendix E present the measurements made on the vehicle.

7.7 OCCUPANT RISK FACTORS

Data from the accelerometer, located at the vehicle center of gravity, were digitized for evaluation of occupant risk. In the longitudinal direction, the occupant impact velocity was 19.0 ft/s at 0.151 s, the highest 0.010-s occupant ridedown acceleration was 10.2 Gs from 0.162 to 0.172 s, and the maximum 0.050-s average acceleration was -6.2 Gs between 0.050 and 0.100 s. In the lateral direction, the occupant impact velocity was 15.1 ft/s at 0.151 s, the highest 0.010-s occupant ridedown acceleration was 6.9 Gs from 0.192 to 0.202 s, and the maximum 0.050-s average was 4.5 Gs between 0.272 and 0.322 s. Theoretical Head Impact Velocity (THIV) was 25.3 km/h or 7.0 m/s at 0.143 s; Post-Impact Head Decelerations (PHD) was 10.2 Gs between 0.162 and 0.172 s; and Acceleration Severity Index (ASI) was 0.65 between 0.050 and 0.100 s. These data and other pertinent information from the test are summarized in Figure 7.7. Vehicle angular displacements and accelerations versus time traces are presented in Appendix E, Figures E3 through E9.



Figure 7.3. Vehicle/Installation Positions after Test No. 490023-4.

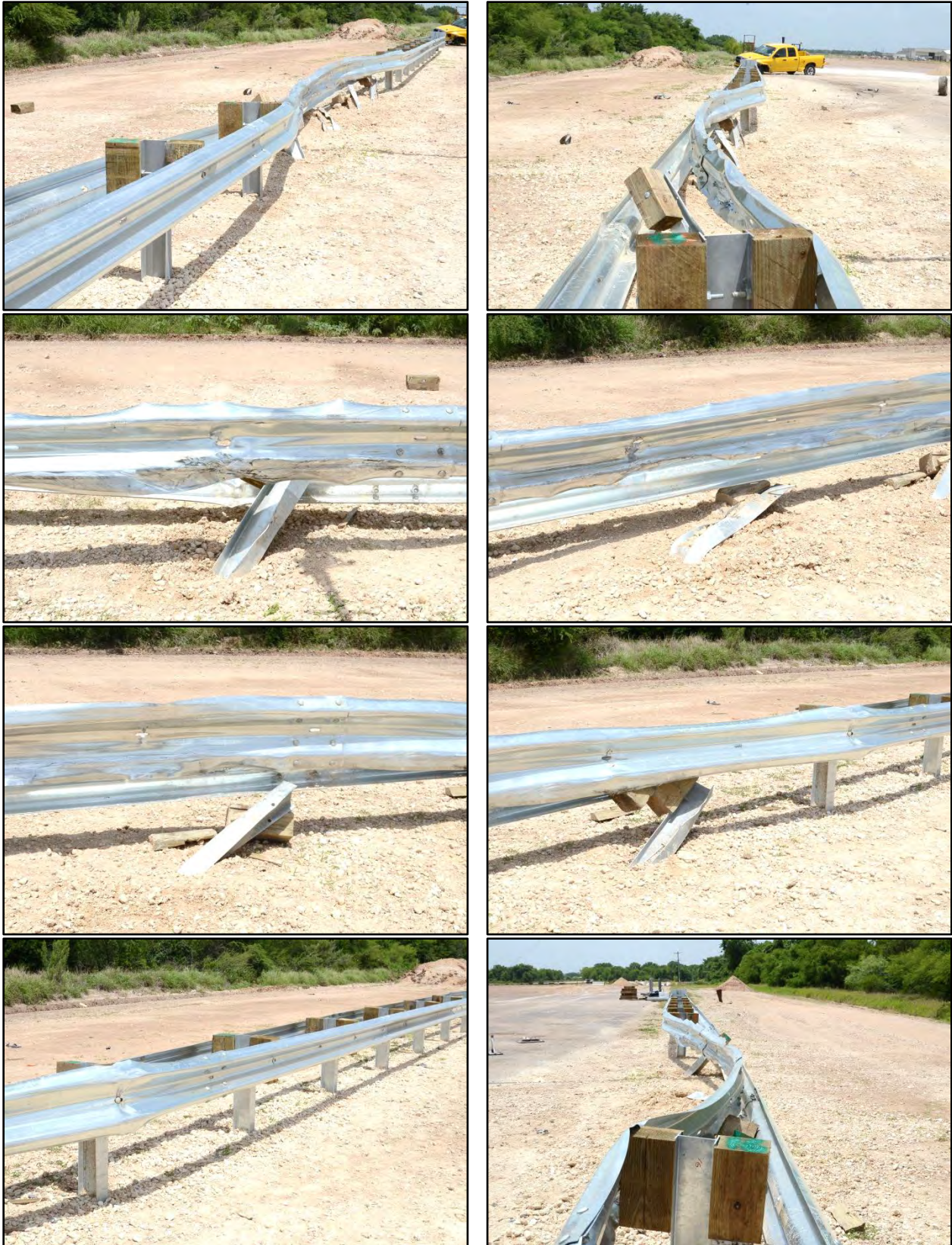

Figure 7.4. Installation after Test No. 490023-4.



Figure 7.5. Vehicle after Test No. 490023-4.



Figure 7.6. Interior of Vehicle for Test No. 490023-4.

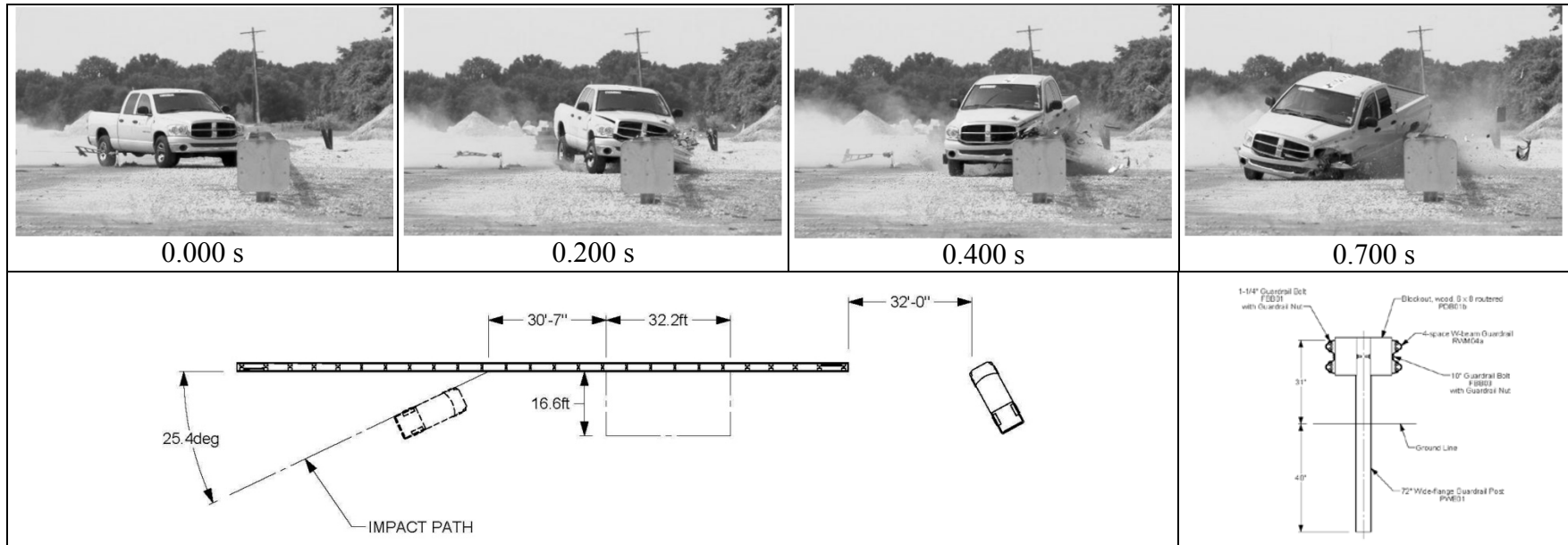

General Information

Test Agency Texas Transportation Institute (TTI)
 Test Standard Test No. MASH Test 3-11
 TTI Test No. 490023-4
 Test Date 2013-06-21

Test Article

Type Median Barrier
 Name TxDOT 31-inch W-Beam Median Barrier
 Installation Length 156 ft
 Material or Key Elements 12-gauge W-beam at 31 inch height on
 W6x8.5 steel posts spaced 6 ft-3 inch with
 6 inch x 8 inch x 14 inch routed wood
 blockouts with splice midspan between posts

Soil Type and Condition

Standard soil, dry

Test Vehicle

Type/Designation 2270P
 Make and Model 2007 Dodge Ram 1500 Pickup
 Curb 4880 lb
 Test Inertial 5017 lb
 Dummy No dummy
 Gross Static 5017 lb

Impact Conditions

Speed 63.0 mi/h
 Angle 25.4 degrees
 Location/Orientation 10.8 ft upstream
 of post 13
 Impact Severity 122.5 kip-ft

Exit Conditions

Speed
 Angle

Occupant Risk Values

Impact Velocity
 Longitudinal 19.0 m/s
 Lateral 15.1 m/s
 Ridedown Accelerations
 Longitudinal 10.2 G
 Lateral 6.9 G
 THIV 7.0 m/s
 PHD 10.2 G
 ASI 0.65
 Max. 0.050-s Average
 Longitudinal -6.2 G
 Lateral 4.5 G
 Vertical 3.4 G

Post-Impact Trajectory

Stopping Distance 119.5 ft downstrm

Vehicle Stability

Maximum Yaw Angle 47 degrees
 Maximum Pitch Angle 11 degrees
 Maximum Roll Angle 12 degrees
 Vehicle Snagging No
 Vehicle Pocketing No

Test Article Deflections

Dynamic 39.0 inches
 Permanent 29.5 inches
 Working Width 55.0 inches
 Vehicle Intrusion 50.3 inches

Vehicle Damage

VDS 11LFQ3
 CDC 11FLEW3
 Max. Exterior Deformation 11.0 inches
 OCDI LF0000000
 Max. Occupant Compartment
 Deformation None

Figure 7.7. Summary of Results for MASH Test 3-11 on the TxDOT 31-Inch W-Beam Median Barrier.

7.1 ASSESSMENT OF TEST RESULTS

An assessment of the test based on the applicable *MASH* safety evaluation criteria is provided below.

7.1.1 Structural Adequacy

- A. *Test article should contain and redirect the vehicle or bring the vehicle to a controlled stop; the vehicle should not penetrate, underride, or override the installation although controlled lateral deflection of the test article is acceptable.*

Results: The TxDOT 31-inch W-Beam Median Barrier contained and redirected the 2270P vehicle. The vehicle did not penetrate, underride, or override the installation. Maximum dynamic deflection during the test was 39.0 inches. (PASS)

7.1.2 Occupant Risk

- D. *Detached elements, fragments, or other debris from the test article should not penetrate or show potential for penetrating the occupant compartment, or present an undue hazard to other traffic, pedestrians, or personnel in a work zone.*

Deformation of, or intrusions into, the occupant compartment should not exceed limits set forth in Section 5.3 and Appendix E of MASH (roof ≤ 4.0 inches; windshield = ≤ 3.0 inches; side windows = no shattering by test article structural member; wheel/foot well/toe pan ≤ 9.0 inches; forward of A-pillar ≤ 12.0 inches; front side door area above seat ≤ 9.0 inches; front side door below seat ≤ 12.0 inches; floor pan/transmission tunnel area ≤ 12.0 inches).

Results: The rail element and some blockouts separated from the posts, however, these did not penetrate nor show potential for penetrating the occupant compartment, nor did the present hazard to others in the area. (PASS)
No occupant compartment deformation occurred. (PASS)

- F. *The vehicle should remain upright during and after collision. The maximum roll and pitch angles are not to exceed 75 degrees.*

Results: The 2270P vehicle remained upright during and after the collision event. Maximum roll and pitch angles were 11 degrees and 11 degrees, respectively. (PASS)

- I. *Occupant impact velocities should satisfy the following:*
Longitudinal and Lateral Occupant Impact Velocity

<u>Preferred</u>	<u>Maximum</u>
30 ft/s	40 ft/s

Results: Longitudinal occupant impact velocity was 19.0 ft/s, and lateral occupant impact velocity was 15.1 ft/s. (PASS)

I. *Occupant ridedown accelerations should satisfy the following:*

Longitudinal and Lateral Occupant Ridedown Accelerations

Preferred

15.0 Gs

Maximum

20.49 Gs

Results: Maximum longitudinal ridedown acceleration was 10.2 G, and maximum lateral ridedown acceleration was 6.9 G. (PASS)

7.1.3 Vehicle Trajectory

For redirective devices, the vehicle shall exit the barrier within the exit box (not less than 32.8 ft).

Result: The 2270P vehicle exited the installation within the limits specified above. (PASS)

CHAPTER 8. SUMMARY AND CONCLUSIONS

8.1 SUMMARY OF TEST RESULTS

8.1.1 *MASH* Test 3-10 (Crash Test No. 490023-3)

The TxDOT 31-inch W-Beam Median Barrier contained and redirected the 1100C vehicle. The vehicle did not penetrate, underride, or override the installation. Maximum dynamic deflection during the test was 25.4 inches. Three blockouts separated from posts. One blockout split apart and came to rest beneath the rail; one blockout came to rest 15 ft toward the opposite side of impact; and the third came to rest 10 ft toward traffic lanes. These blockouts did not penetrate or show potential for penetrating the occupant compartment. No occupant compartment deformation occurred. The 1100C vehicle remained upright during and after the collision event. Occupant risk factors were within the specified limits in *MASH*. The 1100C vehicle exited within the exit box criteria.

8.1.2 *MASH* Test 3-11 (Crash Test No. 490023-4)

The TxDOT 31-inch W-Beam Median Barrier contained and redirected the 2270P vehicle. The vehicle did not penetrate, underride, or override the installation. Maximum dynamic deflection during the test was 39.0 inches. The rail element and some blockouts separated from the posts, however, these did not penetrate nor show potential for penetrating the occupant compartment, nor did the present hazard to others in the area. No occupant compartment deformation occurred. The 2270P vehicle remained upright during and after the collision event. Maximum roll and pitch angles were 11 degrees and 11 degrees, respectively. Occupant risk factors were within the specified limits in *MASH*. The 2270P vehicle exited within the exit box criteria.

8.2 CONCLUSIONS

TTI researchers developed and successfully tested a 31-inch tall strong post W-beam median barrier. The barrier utilizes standard 6 ft long W6×8.5 steel posts spaced 6 ft-3 inches on center. The W-beam guardrails are offset from the posts using non-steel blockouts nominally 6 inch × 8 inch × 14 inch. The system was tested under both *MASH* TL 3-10 and TL 3-11 test conditions and passed all applicable *MASH* evaluation criteria associated with these tests as shown in Tables 8.1 and 8.2.

Table 8.1. Performance Evaluation Summary for MASH Test 3-10 on the TxDOT 31-Inch W-Beam Median Barrier.

Test Agency: Texas Transportation Institute

Test No.: 490023-3

Test Date: 2013-06-18

MASH Test 3-10 Evaluation Criteria	Test Results	Assessment
Structural Adequacy <i>A. Test article should contain and redirect the vehicle or bring the vehicle to a controlled stop; the vehicle should not penetrate, underride, or override the installation although controlled lateral deflection of the test article is acceptable</i>	The TxDOT 31-inch W-Beam Median Barrier contained and redirected the 1100C vehicle. The vehicle did not penetrate, underride, or override the installation. Maximum dynamic deflection during the test was 25.4 inches.	Pass
Occupant Risk <i>D. Detached elements, fragments, or other debris from the test article should not penetrate or show potential for penetrating the occupant compartment, or present an undue hazard to other traffic, pedestrians, or personnel in a work zone.</i>	Three blockouts separated from posts. One blockout split apart and came to rest beneath the rail; one blockout came to rest 15 ft toward the opposite side of impact; and the third came to rest 10 ft toward traffic lanes. These blockouts did not penetrate or show potential for penetrating the occupant compartment.	Pass
<i>Deformations of, or intrusions into, the occupant compartment should not exceed limits set forth in Section 5.3 and Appendix E of MASH.</i>	No occupant compartment deformation occurred.	Pass
<i>F. The vehicle should remain upright during and after collision. The maximum roll and pitch angles are not to exceed 75 degrees.</i>	The 1100C vehicle remained upright during and after the collision event. Maximum roll and pitch angles during the test were 11 degrees and 9 degrees, respectively.	Pass
<i>H. Longitudinal and lateral occupant impact velocities should fall below the preferred value of 30 ft/s, or at least below the maximum allowable value of 40 ft/s.</i>	Longitudinal occupant impact velocity was 20.0 ft/s, and lateral occupant impact velocity was 17.4 ft/s.	Pass
<i>I. Longitudinal and lateral occupant ridedown accelerations should fall below the preferred value of 15.0 Gs, or at least below the maximum allowable value of 20.49 Gs.</i>	Longitudinal ridedown acceleration was 9.6 G, and lateral ridedown acceleration was 8.3 G.	Pass
Vehicle Trajectory <i>For redirective devices, the vehicle shall exit the barrier within the exit box (not less than 32.8 ft).</i>	The 1100C vehicle exited within the criteria specified for the exit box.	Pass

Table 8.2. Performance Evaluation Summary for MASH Test 3-11 on the TxDOT 31-Inch W-Beam Median Barrier.

Test Agency: Texas Transportation Institute

Test No.: 490023-4

Test Date: 2013-06-21

MASH Test 3-11 Evaluation Criteria	Test Results	Assessment
Structural Adequacy <i>A. Test article should contain and redirect the vehicle or bring the vehicle to a controlled stop; the vehicle should not penetrate, underride, or override the installation although controlled lateral deflection of the test article is acceptable</i>	The TxDOT 31-inch W-Beam Median Barrier contained and redirected the 2270P vehicle. The vehicle did not penetrate, underride, or override the installation. Maximum dynamic deflection during the test was 39.0 inches.	Pass
Occupant Risk <i>D. Detached elements, fragments, or other debris from the test article should not penetrate or show potential for penetrating the occupant compartment, or present an undue hazard to other traffic, pedestrians, or personnel in a work zone.</i>	The rail element and some blockouts separated from the posts, however, these did not penetrate nor show potential for penetrating the occupant compartment, nor did the present hazard to others in the area.	Pass
<i>Deformations of, or intrusions into, the occupant compartment should not exceed limits set forth in Section 5.3 and Appendix E of MASH.</i>	No occupant compartment deformation occurred.	Pass
<i>F. The vehicle should remain upright during and after collision. The maximum roll and pitch angles are not to exceed 75 degrees.</i>	The 2270P vehicle remained upright during and after the collision event. Maximum roll and pitch angles were 11 degrees and 11 degrees, respectively.	Pass
<i>H. Longitudinal and lateral occupant impact velocities should fall below the preferred value of 30 ft/s, or at least below the maximum allowable value of 40 ft/s.</i>	Longitudinal occupant impact velocity was 19.0 ft/s, and lateral occupant impact velocity was 15.1 ft/s.	Pass
<i>I. Longitudinal and lateral occupant ridedown accelerations should fall below the preferred value of 15.0 Gs, or at least below the maximum allowable value of 20.49 Gs.</i>	Maximum longitudinal ridedown acceleration was 10.2 G, and maximum lateral ridedown acceleration was 6.9 G.	Pass
Vehicle Trajectory <i>For redirective devices, the vehicle shall exit the barrier within the exit box.</i>	The 2270P vehicle exited the installation within the limits specified above.	Pass

CHAPTER 9. IMPLEMENTATION STATEMENT

A new strong steel post W-beam median barrier design was developed and tested. The TxDOT 31-inch W-Beam Median Barrier design adds a crashworthy semi-rigid median barrier alternative to TxDOT's safety hardware standards. The design successfully met MASH impact performance criteria for both the small passenger car test (test 3-10) and pickup truck test (test 3-11). Moreover, the TxDOT 31-inch W-Beam Median Barrier design uses readily available components and does not require any new inventory.

Based on the successful crash testing, the new strong steel post W-beam median barrier design is considered ready for immediate implementation. The system is suitable for use in medians that can accommodate a dynamic deflection of 39 inches and a working width of 55 inches. This system was evaluated on flat terrain and, thus, its implementation should be on surfaces that have a grade of 1V:10H or flatter.

Full installation drawings and details for the new strong steel post W-beam median barrier design are contained herein to aid TxDOT with its incorporation into TxDOT standards.

REFERENCES

1. K. A. Polivka, R. K. Faller, D. L. Sicking, J. R. Rohde, B. W. Bielenberg, J. D. Reid, "Performance Evaluation of the Modified G4(1S) Guardrail – Update to NCHRP 350 Test No. 3-11 (2214WB-1)," Research Report TRP-03-168-06, Midwest Roadside Safety Facility, Lincoln, NE, October 2006.
2. K. A. Polivka, R. K. Faller, D. L. Sicking, J. R. Rohde, B. W. Bielenberg, J. D. Reid, "Performance Evaluation of the Modified G4(1S) Guardrail – Update to NCHRP 350 Test No. 3-11 with 28" C.G. Height (2214-WB-2)," Research Report TRP-03-169-06, Midwest Roadside Safety Facility, Lincoln, NE, October 2006.
3. K. A. Polivka, R. K. Faller, D. L. Sicking, J. R. Rohde, B. W. Bielenberg, J. D. Reid, "Performance Evaluation of the Midwest Guardrail System – Update to NCHRP 350 Test No. 3-11 (2214MG-1)," Research Report TRP-03-171-06, Midwest Roadside Safety Facility, Lincoln, NE, October 2006.
4. K. A. Polivka, R. K. Faller, D. L. Sicking, J. R. Rohde, B. W. Bielenberg, J. D. Reid, "Performance Evaluation of the Midwest Guardrail System – Update to NCHRP 350 Test No. 3-11 with 28" C.G. Height (2214MG-2)," Research Report TRP-03-171-06, Midwest Roadside Safety Facility, Lincoln, NE, October 2006.
5. K. A. Polivka, R. K. Faller, D. L. Sicking, J. R. Rohde, B. W. Bielenberg, J. D. Reid, "Performance Evaluation of the Midwest Guardrail System – Update to NCHRP 350 Test No. 3-10 (2214MG-3)," Research Report TRP-03-172-06, Midwest Roadside Safety Facility, Lincoln, NE, October 2006.
6. K. A. Polivka, R. K. Faller, D. L. Sicking, J. R. Rohde, B. W. Bielenberg, J. D. Reid, B. A. Coon, "Performance Evaluation of the Free-Standing Temporary Barrier – Update to NCHRP 350 Test No. 3-11 (2214TB-1)," Research Report TRP-03-173-06, Midwest Roadside Safety Facility, Lincoln, NE, October 2006.
7. K. A. Polivka, R. K. Faller, D. L. Sicking, J. R. Rohde, B. W. Bielenberg, J. D. Reid, B. A. Coon, "Performance Evaluation of the Free-Standing Temporary Barrier – Update to NCHRP 350 Test No. 3-11 with 28" C.G. Height (2214TB-2)," Research Report TRP-03-174-06, Midwest Roadside Safety Facility, Lincoln, NE, October 2006.
8. R. P. Bligh, N. M. Sheikh, W. L. Menges, R. R. Haug, "Development of Low-Deflection Precast Concrete Barrier," Research Report 0-4162-3, Texas Transportation Institute, College Station, TX, January 2005.
9. K. A. Polivka, R. K. Faller, D. L. Sicking, J. R. Rohde, B. W. Bielenberg, J. D. Reid, B. A. Coon, "Performance Evaluation of the Permanent New Jersey Safety Shape Barrier – Update to NCHRP 350 Test No. 3-10 (2214NJ-1)," Research Report TRP-03-177-06, Midwest Roadside Safety Facility, Lincoln, NE, October 2006.
10. K. A. Polivka, R. K. Faller, D. L. Sicking, J. R. Rohde, B. W. Bielenberg, J. D. Reid, B. A. Coon, "Performance Evaluation of the Permanent New Jersey Safety Shape Barrier – Update to NCHRP 350 Test No. 4-12 (2214NJ-2)," Research Report TRP-03-178-06, Midwest Roadside Safety Facility, Lincoln, NE, October 2006.

11. K. A. Polivka, R. K. Faller, D. L. Sicking, J. R. Rohde, B. W. Bielenberg, J. D. Reid, B. A. Coon, "Performance Evaluation of the Guardrail to Concrete Barrier Transition – Update to NCHRP 350 Test No. 3-21 with 28" C.G. Height (2214T-1)," Research Report TRP-03-175-06, Midwest Roadside Safety Facility, Lincoln, NE, October 2006.
12. K. A. Polivka, R. K. Faller, D. L. Sicking, J. R. Rohde, B. W. Bielenberg, J. D. Reid, B. A. Coon, "Performance Evaluation of the SKT-MGS Tangent End Terminal – Update to NCHRP 350 Test No. 3-34 (2214TT-1)," Research Report TRP-03-175-06, Midwest Roadside Safety Facility, Lincoln, NE, October 2006.
13. R. P. Bligh, W. L. Menges, "Initial Assessment of Compliance of Texas Roadside Safety Hardware with Proposed Update to NCHRP Report 350," Research Report 0-5526-1, Texas Transportation Institute, College Station, TX, September 2007.
14. D. L. Bullard, Jr., Roger P. Bligh, Wanda L. Menges, and Rebecca R. Haug, "Evaluation of Existing Roadside Safety Hardware Using Updated Criteria – Technical Report," National Highway Research Cooperative Program, [NCHRP Web-Only Document 157](#): Project 22-14(03), Transportation Research Board, , Washington, D.C., March 2010.
15. H. E. Ross, D. L. Sicking, R. A. Zimmer, and J. D. Michie, *Recommended Procedures for the Safety Performance Evaluation of Highway Features*, National Cooperative Highway Research Program Report 350, Transportation Research Board, National Research Council, Washington, D.C., 1993.
16. American Association of State Highway and Transportation Officials, *Manual for Assessing Safety Hardware*, AASHTO Subcommittee on Bridges and Structures, Washington, D.C., 2009.
17. FHWA Memorandum: *ACTION: Roadside Design: Steel Strong Post W-beam Guardrail*. http://safety.fhwa.dot.gov/roadway_dept/policy_guide/road_hardware/policy_memo/memo051710/, dated May 17, 2010; last accessed on October 22, 2013.
18. National Crash Analysis Center. NCAC Finite Element Model Archive. <http://www.ncac.gwu.edu/vml/models.html>. Accessed: Dec 10, 2008.
19. A. Y. Abu-Odeh, R. P. Bligh, D. L. Bullard, and W. L. Menges. "Crash testing and Evaluation of the modified G4(1S) W-Beam Guardrail on 2:1 Slope." TTI Report No. 405160-4-1. Texas A&M Transportation Institute, College Station, TX, 2008.
20. J. O. Hallquist. "LS-DYNA: Keyword User's Manual, Version 971," Livermore Software Technology Corporation (LSTC), Livermore, CA, 2007.

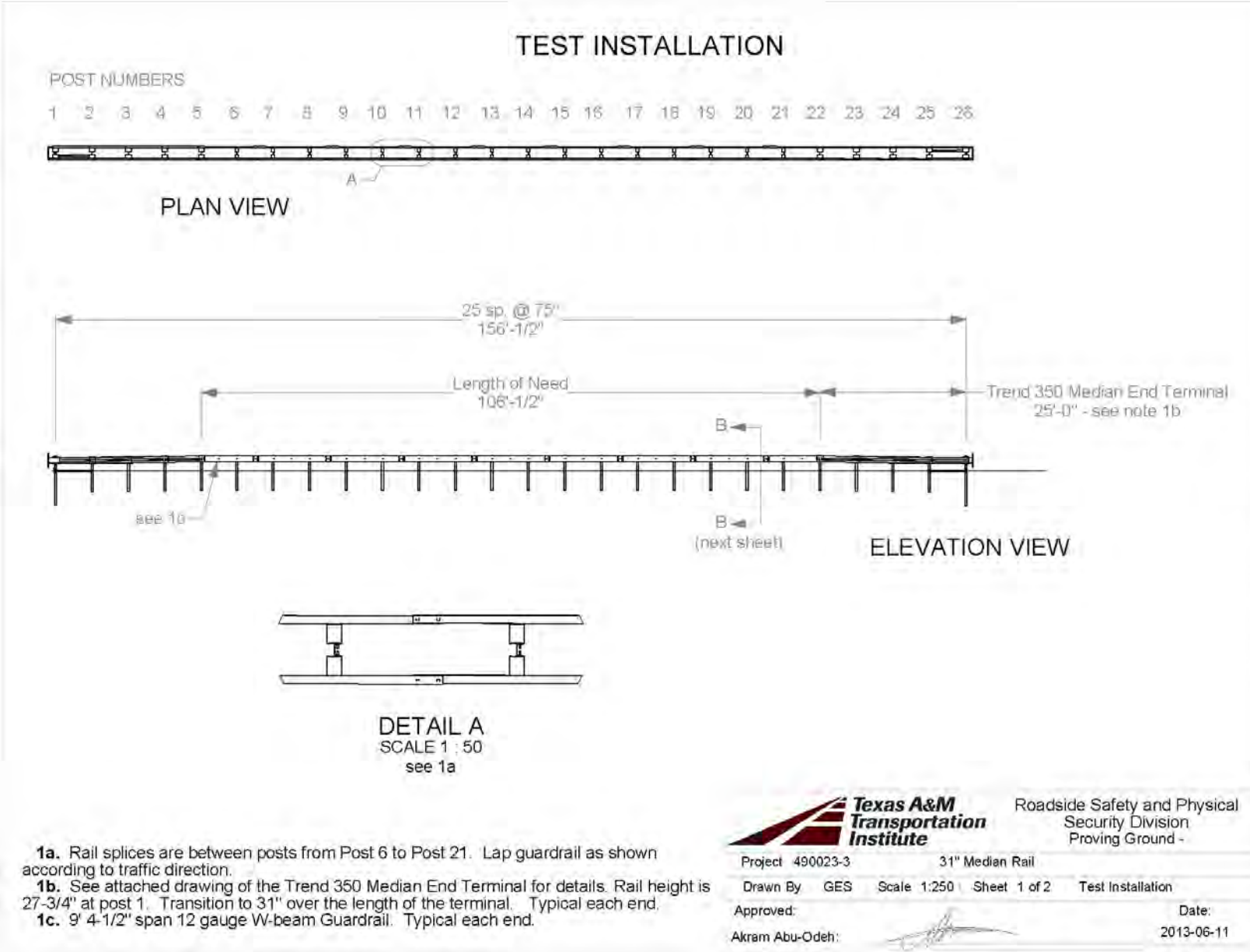

T:\2012-2013\490023 TxDO\3.-4 Median Rail\Drafting\2013-06-10\490023-3 Drawing

SECTION B-B
SCALE 1 : 20
TYP at Posts 6 - 21

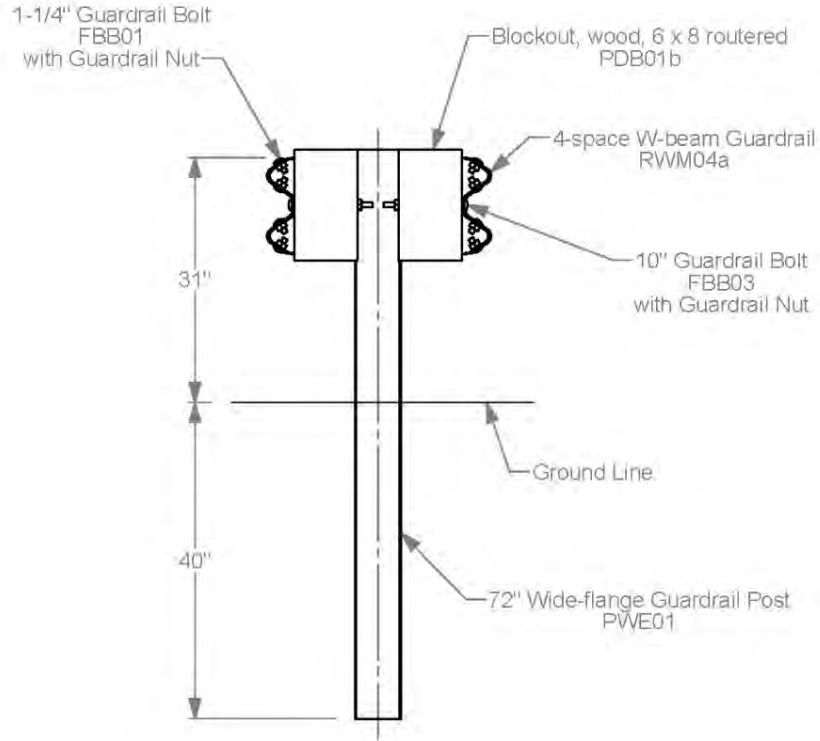

Roadside Safety and
Physical Security Division -
Proving Ground

Project 490023-3	31" Median Rail	2013-06-11
Drawn By GES	Scale:1:150	Sheet 2 of 2 Length of Need

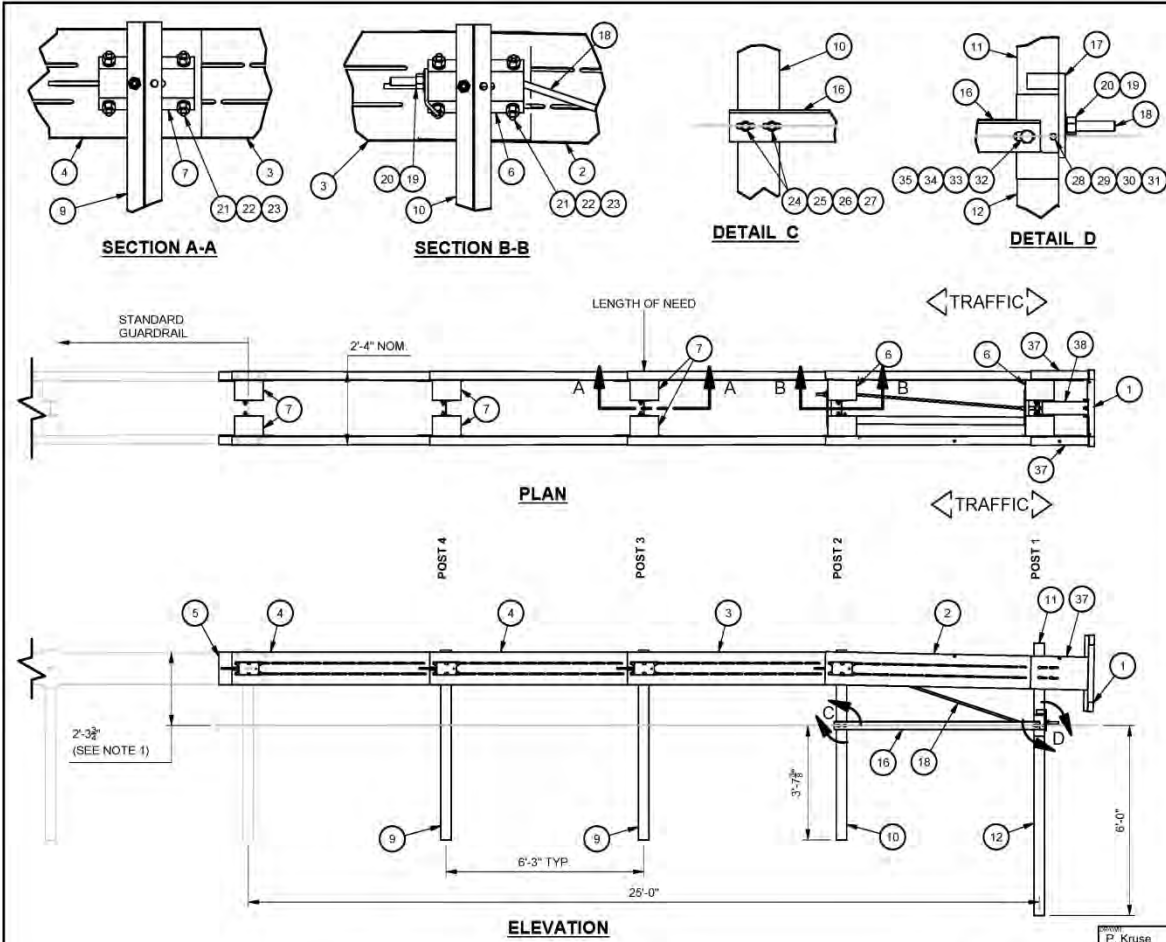

PARTS LIST			
ITEM	STOCK NO.	DESCRIPTION	QTY.
1	618586B	HEAD,350TEM,G,WDECAL	1
2	618212G	RAIL,W-SHAPE,2484,350TEM,G	2
3	618192G	RAIL,W-SHAPE,2228,G	2
4	618193G	RAIL,W-SHAPE,2228,WFIN,G	4
5	613554G	RAIL,WFIN,W-SHAPE,525,G	2
6	618007G	SPACER,350TEM,G	2
7	618008G	SPACER,POST/RAIL,350TEM,G	6
8	604655G	BACKING PLATE,POST,TE,G	8
9	000533G	6" POST/8 5/DDP	2
10	014578G	6" PST/8 5/SYTP	1
11	034074A	TRND350 HBA BKY PST2"8 75	1
12	033873A	ET HBA P1-2 BTM X 6-1 1/2	1
13	003403G	5/8"X2" HEX BOLT A307	10
14	617000G	WASHER,BAR,1/4X2X89M,WSLOT,G	10
15	003340G	NUT,HX,5/8,G,RAIL	10
16	033795G	SYT-3"AN STRT 3-HL 6"6	1
17	019258A	HBA,BRG,PLWELDED,TABS	1
18	003012G	CBL,3/4X8"DBL,SWG	1
19	003900G	1" ROUND WASHER F844	2
20	003910G	1" HEX NUT A563	2
21	118614G	BOLT,RAIL,5/8X2,G5,G	58
22	118615G	WASHER,FLAT,5/8,THICK,G	58
23	115971G	NUT,HX,5/8,G,GR DH	58
24	004390G	7/16"X1.5" HEX BOLT GRD 5	2
25	004389G	7/16" WASHER F844	2
26	004393G	7/16" LOCK WASHER	2
27	004396G	7/16" HEX NUT A563 DH	2
28	006321G	3/8"X2" HEX BOLT GR-5 HDG	2
29	004254G	3/8" ROUND WASHER F436	2
30	004258G	3/8" LOCK WASHER	2
31	006405G	3/8" HVY HEX NUT A563GRDH	2
32	003717G	3/4"X2.5" HEX BOLT A325	2
33	003701G	3/4" ROUND WASHER F436	2
34	004699G	3/4" LOCK WASHER	2
35	003704G	3/4" HVY HEX NUT A563 DH	2
36	618081B	INSTALLATION INSTRUCTS,TREND 350 MEDIAN	1
37	618444G	RAIL,HEAD,TEM,G	2
38	620080G	TUBE,HEAD,350TEM,G	1

NOTE:
1. SYSTEM CAN BE ATTACHED TO DOWNSTREAM GUARDRAIL WITH HEIGHTS UP TO 31"

Revision	ECO	Date	Rev	By	Chk	App
ITEM 1 WAS 618010G, ADDED ITEM 37, UPDATED QTY OF ITEMS 21-23	3198	10/13/11	C	PLK	JME	BSS
ITEMS 21,22,23 WERE 113098G,118069G&119011G RESP	3403	05/16/12	D	PLK	STT	BSS
ITEMS 9,13,16,20,30&34 WERE 540G,118059G,118004G,119031G,118022G&288G RESP. ADD ITEM 36. UPD VIEWS	3432	07/19/12	E	PLK	JME	BSS

DESIGNED BY	P. Kruse	DATE	2/10/2011
CHECKED BY	P. Kruse	DATE	3/15/2011
DESIGNED BY	JME	DATE	6/15/2011
DESIGNED BY	B. Sindorf	DATE	6/3/2011

MODEL NO. 618082B 1005.04 lbmass

ENERGY ABSORPTION SYSTEMS
ENGINEERING AND RESEARCH DEPARTMENT

TREND 350 MEDIAN END TERMINAL

618082 1 of 2 E

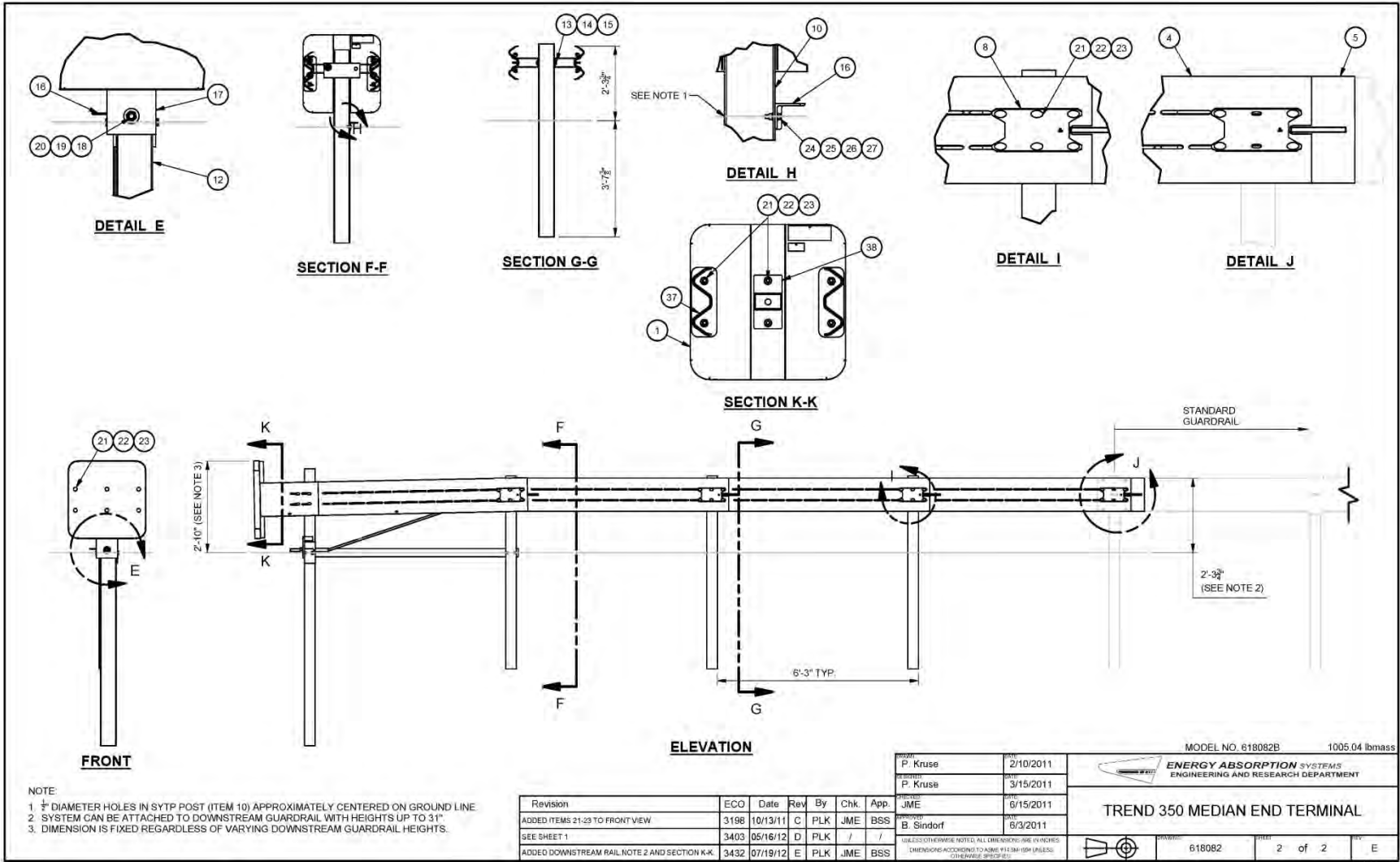

NOTE
 1. 1/2" DIAMETER HOLES IN SYTP POST (ITEM 10) APPROXIMATELY CENTERED ON GROUND LINE
 2. SYSTEM CAN BE ATTACHED TO DOWNSTREAM GUARDRAIL WITH HEIGHTS UP TO 31"
 3. DIMENSION IS FIXED REGARDLESS OF VARYING DOWNSTREAM GUARDRAIL HEIGHTS.

Revision	ECO	Date	Rev	By	Chk.	App.
ADDED ITEMS 21-23 TO FRONT VIEW	3198	10/13/11	C	PLK	JME	BSS
SEE SHEET 1	3403	05/16/12	D	PLK	/	/
ADDED DOWNSTREAM RAIL NOTE 2 AND SECTION K-K	3432	07/19/12	E	PLK	JME	BSS

DESIGNED BY	P. Kruse	DATE	2/10/2011
CHECKED BY	P. Kruse	DATE	3/15/2011
APPROVED BY	JME	DATE	6/15/2011
APPROVED BY	B. Sindorf	DATE	6/3/2011

MODEL NO. 618082B 1005.04 lbmass

ENERGY ABSORPTION SYSTEMS
 ENGINEERING AND RESEARCH DEPARTMENT

TREND 350 MEDIAN END TERMINAL

UNLESS OTHERWISE NOTED, ALL DIMENSIONS ARE IN INCHES
 DIMENSIONS ACCORDING TO ASME Y14.5M (UNLESS OTHERWISE SPECIFIED)

618082 2 of 2 E

APPENDIX B. CERTIFICATION DOCUMENTATION

MATERIAL USED

TEST NUMBER 490023-3 and 4
TEST NAME Median Rail
DATE 2013-06-18

DATE RECEIVED	ITEM NUMBER	DESCRIPTION	SUPPLIER	HEAT #
2013-06-10	12-Parts-01	Guardrail Parts	Trinity	see file
2013-06-05	Blockout-12-01	6 x 8 x 14 routed	Trinity	none

Certified Analysis



Trinity Highway Products, LLC
 2548 N.E. 28th St.
 Ft Worth, TX 76111
 Customer: SAMPLES, TESTING, TRAINING MTRLS
 2525 STEMMONS FRWY
 DALLAS, TX 75207
 Project: THP TEST MATERIAL

Order Number: 1198833 Prod Ln Grp: 9-End Terminals (Dom)
 Customer PO:
 BOL Number: 47567 Ship Date:
 Document #: 1
 Shipped To: TX
 Use State: TX

As of: 6/7/13

Qty	Part #	Description	Spec	CL	TY	Heat Code/Heat	Yield	TS	Elg	C	Mn	P	S	Si	Cu	Cb	Cr	Vn	ACW
11	11G	12/12/6/3/1.5/S				F11713													
			M-180	A		B302626	63,900	83,400	26.0	0.200	0.700	0.010	0.005	0.020	0.090	0.001	0.050	0.003	4
			M-180	A		B302628	63,900	83,400	26.0	0.200	0.700	0.010	0.005	0.020	0.090	0.001	0.050	0.003	4
			M-180	A		B302630	60,100	80,300	27.0	0.200	0.730	0.010	0.003	0.030	0.100	0.001	0.050	0.004	4
2	32G	12/12/6/6/3/S ET2000 ANC				F12313													
			M-180	A		233242	58,800	80,200	26.0	0.190	0.790	0.011	0.003	0.020	0.140	0.001	0.060	0.002	4
			M-180	A		B303680	60,800	81,300	25.0	0.210	0.720	0.018	0.003	0.030	0.100	0.001	0.060	0.003	4
25	533G	6/0 POST/8 5/DDR				58013721	62,600	78,300	26.6	0.080	1.020	0.016	0.020	0.230	0.290	0.015	0.160	0.003	4
	533G					59054825	60,100	76,100	25.1	0.080	0.830	0.009	0.022	0.240	0.330	0.013	0.130	0.002	4
	533G					59054828	61,400	77,000	26.4	0.090	0.900	0.011	0.014	0.200	0.300	0.012	0.150	0.001	4
2	704A	CABLE ANCHOR BRKT				E46000	68,425	78,404	25.0	0.200	0.810	0.013	0.008	0.013	0.030	0.006	0.030	0.001	4
2	3000G	CBL 3/4X6/6/DBL				HW	95032												
125	3340G	5/8" GR HEX NUT				HW	130405N2												
100	3360G	5/8"X1.25" GR BOLT				HW	130426B												
25	3500G	5/8"X10" GR BOLT A307				HW	130419L												
20	3900G	1" ROUND WASHER F844				HW	060119												
20	3910G	1" HEX NUT A563				HW	1244010												
25	6777B	PLYMR BLK 4X7.5X14				HW	4936												

Certified Analysis



Trinity Highway Products, LLC

2548 N.E. 28th St.

Ft Worth, TX 76111

Customer: SAMPLES, TESTING, TRAINING MTRLS

2525 STEMMONS FRWY

DALLAS, TX 75207

Project: THP TEST MATERIAL

Order Number: 1198833

Customer PO:

BOL Number: 47567

Document #: I

Shipped To: TX

Use State: TX

Prod Ln Grp: 9-End Terminals (Dom)

Ship Date:

As of: 6/7/13

Qty	Part #	Description	Spec	Cl.	TY	Heat Code/Heat	Yield	TS	Elg	C	Mn	P	S	Si	Cu	Cb	Cr	Vn	ACW
1	15000G	60 SYT PST/8.5/31" GR HT	A-36			11553	49,000	71,000	25.5	0.120	0.700	0.022	0.024	0.250	0.300	0.002	0.260	0.005	4
2	19258A	HBA-BRG PL/WELDED	A-36			1024916	55,200	76,900	25.0	0.170	0.760	0.018	0.025	0.170	0.320	0.001	0.150	0.032	4
1	33795G	SYT-3" AN STRT 3-HL 6/6	A-36			3037297	55,000	79,900	32.0	0.200	0.850	0.010	0.038	0.190	0.260	0.000	0.060	0.003	4
1	33871A	ET HBA P1 TOP X 2-8 3/4	A-36			1023667	57,220	76,037	28.8	0.120	0.960	0.021	0.045	0.180	0.330	0.001	0.220	0.003	4
1	33873A	ET HBA P1-2 BTM X 6-1 1/2	A-36			JK12106309	56,096	74,046	29.6	0.130	0.650	0.012	0.040	0.200	0.270	0.002	0.110	0.002	4

TL -3 or TL-4 COMPLIANT when installed according to manufactures specifications

Upon delivery, all materials subject to Trinity Highway Products, LLC Storage Stain Policy No. LG-002.

ALL STEEL USED WAS MELTED AND MANUFACTURED IN USA AND COMPLIES WITH THE BUY AMERICA ACT.

ALL GUARDRAIL MEETS AASHTO M-180, ALL STRUCTURAL STEEL MEETS ASTM A36

ALL COATINGS PROCESSES OF THE STEEL OR IRON ARE PERFORMED IN USA AND COMPLIES WITH THE "BUY AMERICA ACT"

ALL GALVANIZED MATERIAL CONFORMS WITH ASTM-123 (US DOMESTIC SHIPMENTS)

ALL GALVANIZED MATERIAL CONFORMS WITH ASTM A123 & ISO 1461 (INTERNATIONAL SHIPMENTS)

BOLTS COMPLY WITH ASTM A-307 SPECIFICATIONS AND ARE GALVANIZED IN ACCORDANCE WITH ASTM A-153, UNLESS OTHERWISE STATED.

NUTS COMPLY WITH ASTM A-563 SPECIFICATIONS AND ARE GALVANIZED IN ACCORDANCE WITH ASTM A-153, UNLESS OTHERWISE STATED.

WASHERS COMPLY WITH ASTM F-436 SPECIFICATION AND/OR F-844 AND ARE GALVANIZED IN ACCORDANCE WITH ASTM F-2329.

3/4" DIA CABLE 6X19 ZINC COATED SWAGED END AISI C-1035 STEEL ANNEALED STUD 1" DIA ASTM 449 AASHTO M30, TYPE II BREAKING STRENGTH - 46000 LB

TR No. 9-1002-12-8

Certified Analysis



Trinity Highway Products , LLC

2548 N.E. 28th St.

Ft Worth, TX 76111

Customer: SAMPLES,TESTING,TRAINING MTRLS
2525 STEMMONS FRWY

DALLAS, TX 75207

Project: THP TEST MATERIAL

Order Number: 1198833

Prod Ln Grp: 9-End Terminals (Dom)

Customer PO:

As of: 6/7/13

BOL Number: 47567

Ship Date:

Document #: 1

Shipped To: TX

Use State: TX

State of Texas, County of Tarrant. Sworn and subscribed before me this 7th day of June, 2013

Notary Public:
Commission Expires: /



Trinity Highway Products, LLC

Certified By:

Luis Ortiz
Quality Assurance

Jomary Luginland

66

2013-10-24

Table C1. Test Day Static Soil Strength Documentation for Test No. 490023-3.

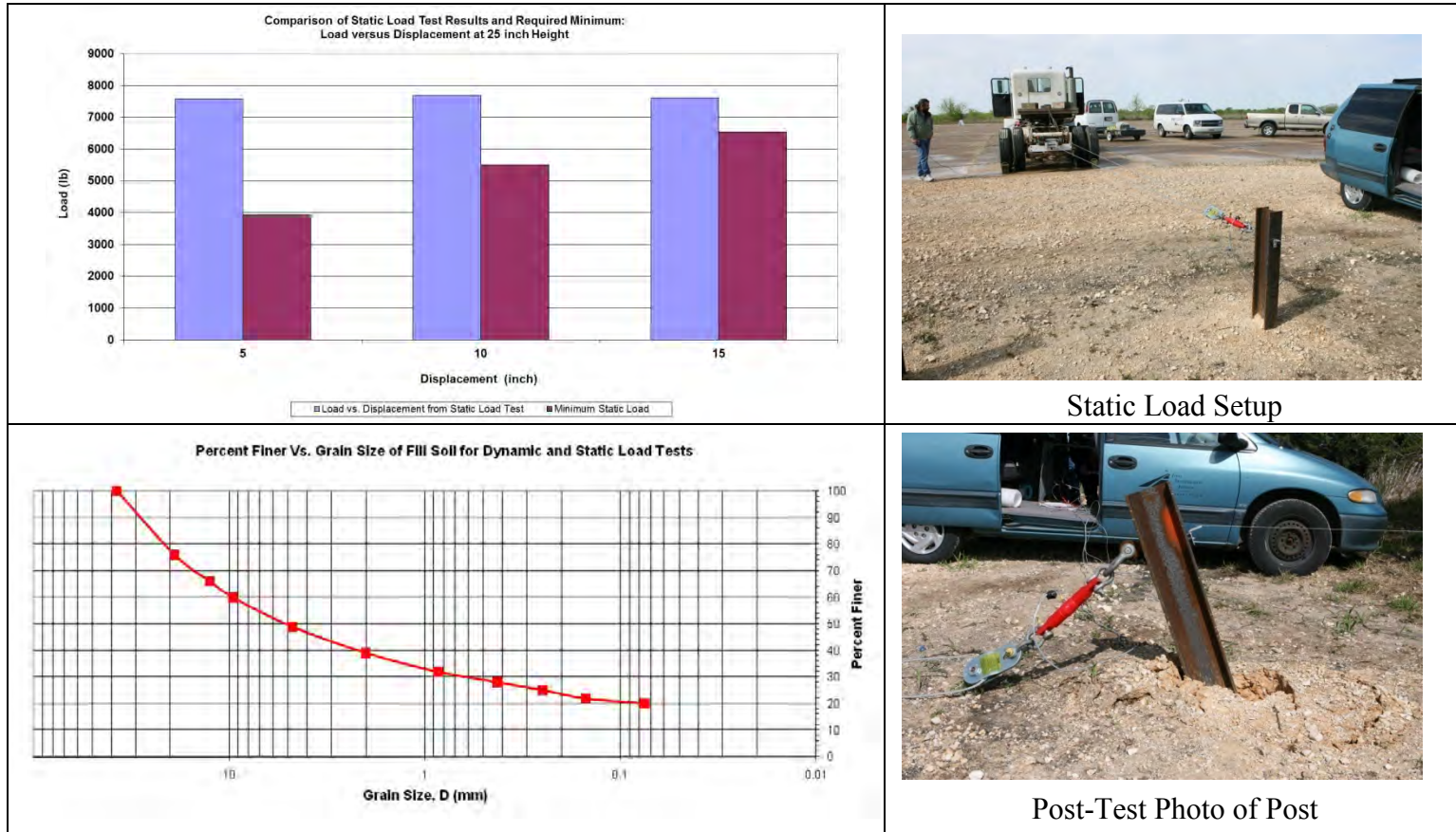

APPENDIX C. SOIL PROPERTIES

Date..... 2013-06-18

Test Facility and Site Location TTI Proving Ground – 3100 SH 47, Bryan, Tx

In Situ Soil Description (ASTM D2487) Sandy gravel with silty fines

Fill Material Description (ASTM D2487) and sieve analysis AASHTO Grade B Soil-Aggregate (see sieve analysis)

Description of Fill Placement Procedure 6-inch lifts tamped with a pneumatic compactor

Table C2. Test Day Static Soil Strength Documentation for Test No. 490023-4.

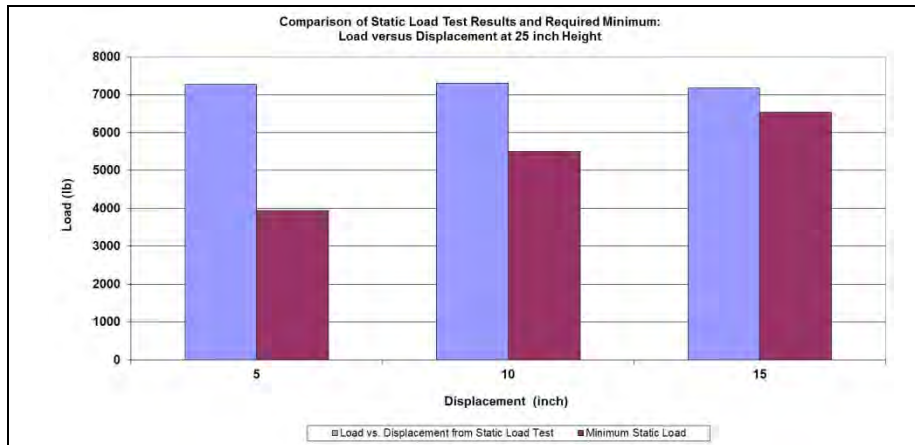

Static Load Setup

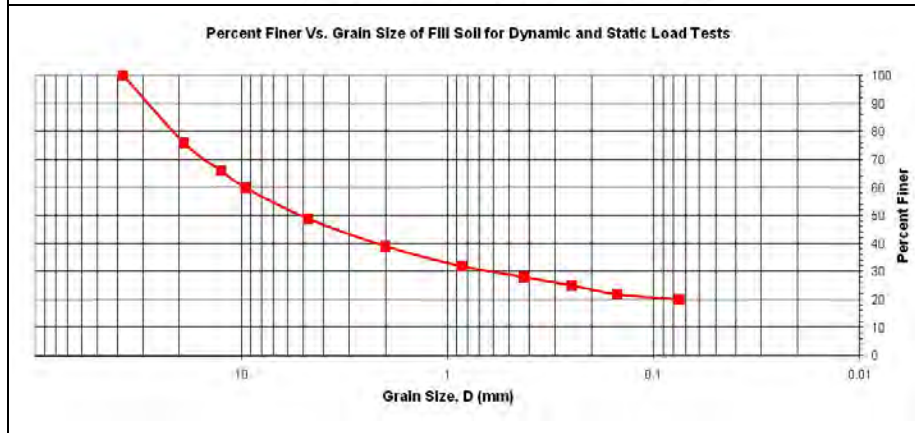

Post-Test Photo of Post

Date..... 2013-06-18

Test Facility and Site Location TTI Proving Ground – 3100 SH 47, Bryan, Tx

In Situ Soil Description (ASTM D2487) Sandy gravel with silty fines

Fill Material Description (ASTM D2487) and sieve analysis AASHTO Grade B Soil-Aggregate (see sieve analysis)

Description of Fill Placement Procedure 6-inch lifts tamped with a pneumatic compactor

Table C3. Summary of Strong Soil Test Results for Establishing Installation Procedure.

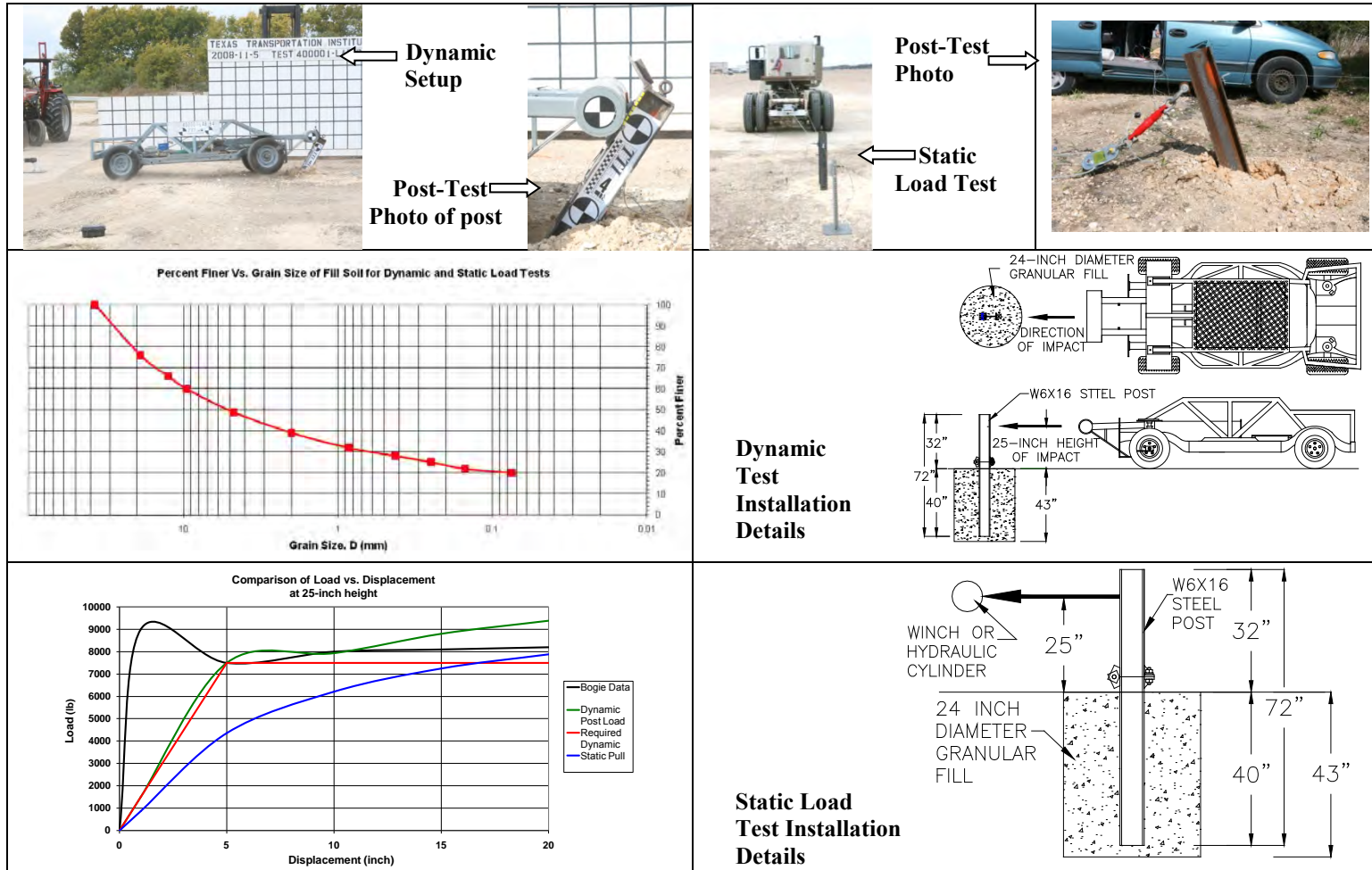

Date	2008-11-05
Test Facility and Site Location	TTI Proving Ground, 3100 SH 47, Bryan, TX 77807
In Situ Soil Description (ASTM D2487)	Sandy gravel with silty fines
Fill Material Description (ASTM D2487) and sieve analysis	AASHTO Grade B Soil-Aggregate (see sieve analysis above)
Description of Fill Placement Procedure	6-inch lifts tamped with a pneumatic compactor
Bogie Weight	5009 lb
Impact Velocity	20.5 mph

APPENDIX D. MASH TEST 3-10 (CRASH TEST NO. 490023-3)

Table D1. Vehicle Properties for Test No. 490023-3.

Date: 2013-06-18 Test No.: 490023-3 VIN No.: KNADE123466137588
 Year: 2006 Make: Kia Model: Rio
 Tire Inflation Pressure: 32 psi Odometer: 94480 Tire Size: 185/65R14

Describe any damage to the vehicle prior to test: _____

• Denotes accelerometer location.

NOTES: _____

Engine Type: 4 cylinder

Engine CID: _____

Transmission Type: _____

Auto or Manual

FWD RWD 4WD

Optional Equipment: _____

Dummy Data: _____

Type: 50th percentile male

Mass: 180 lb

Seat Position: Driver

Geometry: inches

A 66.38 F 33.00

B 57.75 G ----

C 165.75 H 35.23

D 34.00 I 7.12

E 98.75 J 21.00

K 11.00 L 24.12

M 57.75 N 57.12

O 30.52 P 41.12

Q 22.18 R 15.38

S 7.62 T 66.12

U 16.00 V 22.00

W 38.00 X 104.00

Wheel Center Ht Front 11.00 Wheel Center Ht Rear 11.00

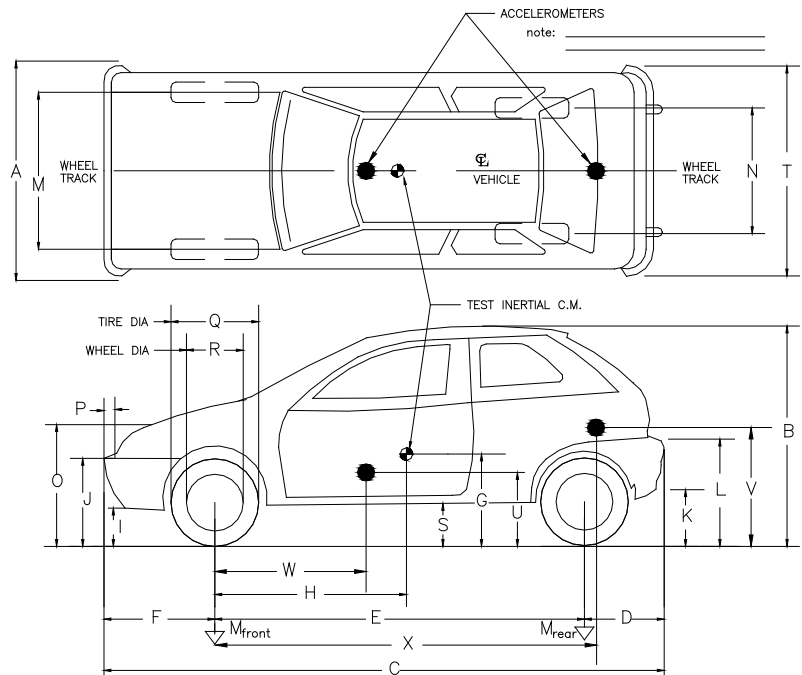

Mass Distribution:

lb LF: 794 RF: 778 LR: 446 RR: 426

Table D3. Occupant Compartment Measurements for Test No. 490023-3.

Date: 2013-06-18 Test No.: 490023-3 VIN No.: KNADE123466137588
 Year: 2006 Make: Kia Model: Rio

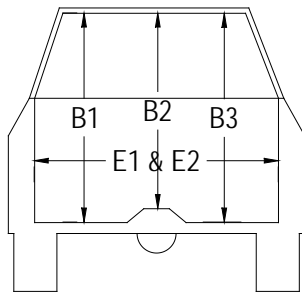
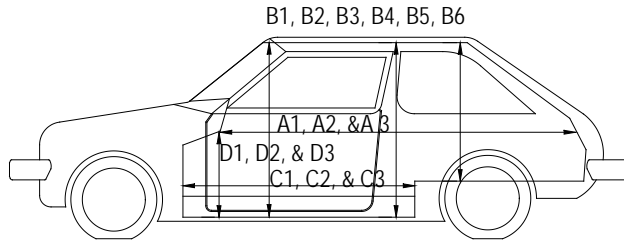
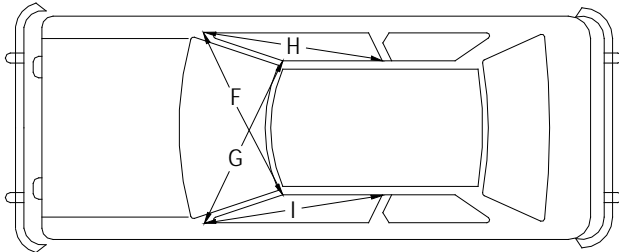

OCCUPANT COMPARTMENT DEFORMATION MEASUREMENT

	Before (inches)	After (inches)
A1	68.00	68.00
A2	67.50	67.50
A3	67.50	67.50
B1	40.50	40.50
B2	36.25	36.25
B3	40.50	40.50
B4	36.25	36.25
B5	36.00	36.00
B6	36.25	36.25
C1	26.50	26.50
C2	----	----
C3	27.50	27.50
D1	9.75	9.75
D2	----	----
D3	9.50	9.50
E1	48.25	48.25
E2	51.25	51.25
F	50.50	50.50
G	50.50	50.50
H	36.75	36.75
I	36.75	36.75
J*	51.00	51.00

*Lateral area across the cab from driver's side kickpanel to passenger's side kickpanel.



0.000 s



0.070 s



0.140 s



0.210 s



Figure D1. Sequential Photographs for Test No. 490023-3 (Overhead and Frontal Views).



0.280s



0.350 s



0.420 s



Out of View

0.490 s



Figure D1. Sequential Photographs for Test No. 490023-3 (Overhead and Frontal Views) (continued).



0.000 s



0.280 s



0.070 s



0.350 s



0.140 s



0.420 s



0.210 s



0.490 s

Figure D2. Sequential Photographs for Test No. 490023-3 (Rear View).

Roll, Pitch, and Yaw Angles

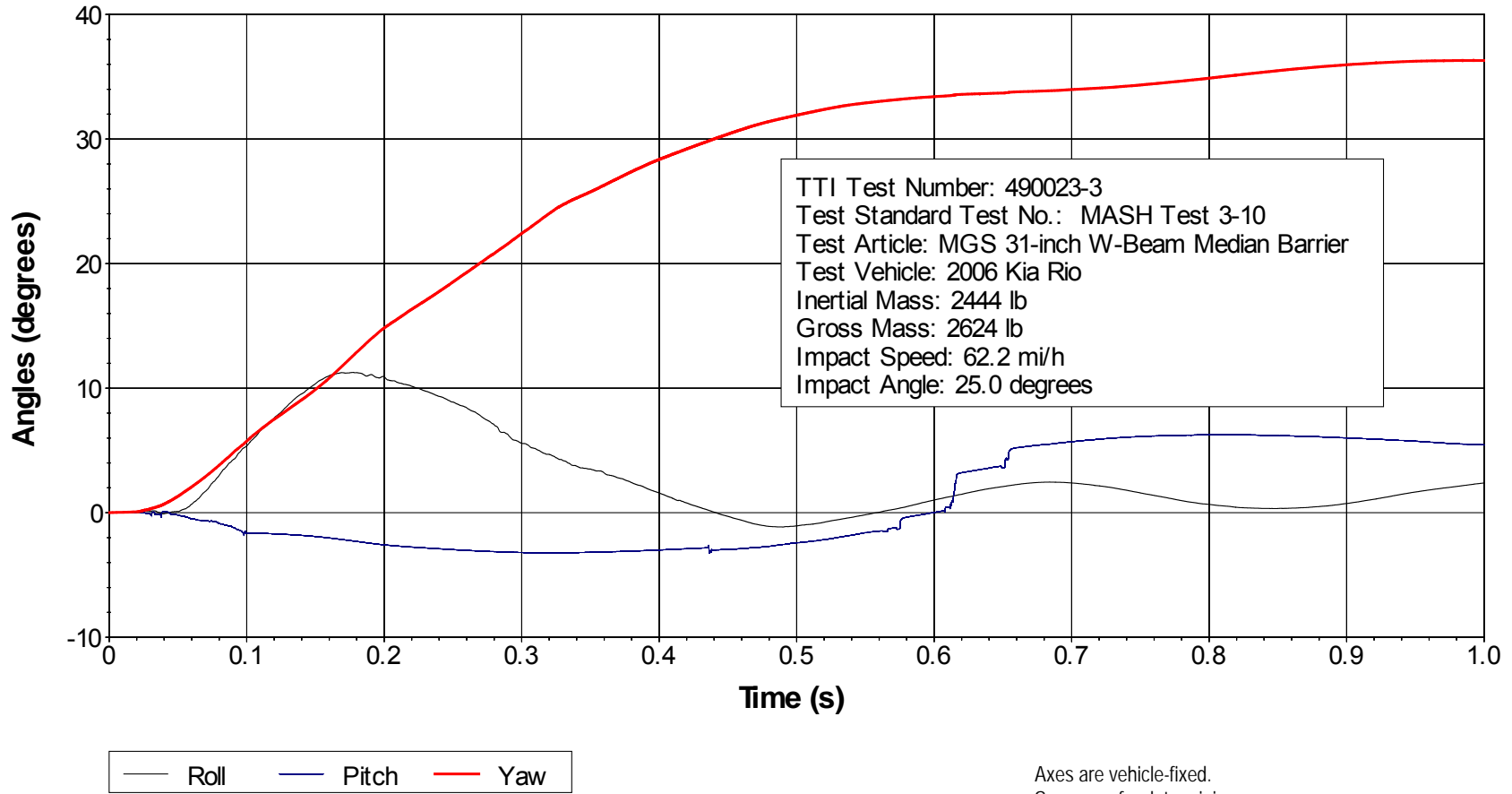

Axes are vehicle-fixed.
Sequence for determining orientation:

1. Yaw.
2. Pitch.
3. Roll.

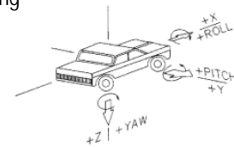

Figure D3. Vehicle Angular Displacements for Test No. 490023-3.

X Acceleration at CG

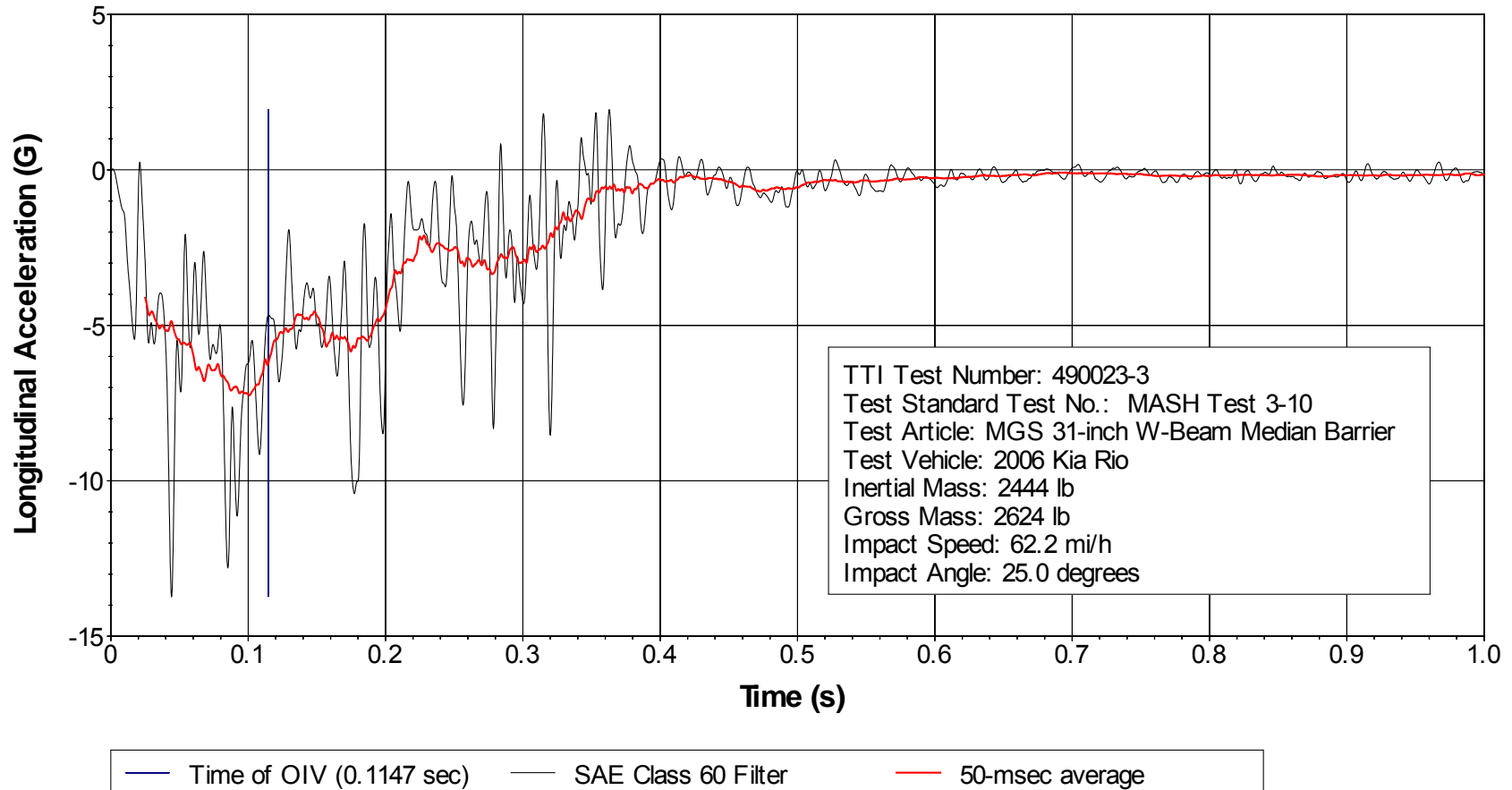

Figure D4. Vehicle Longitudinal Accelerometer Trace for Test No. 490023-3 (Accelerometer Located at Center of Gravity).

Y Acceleration at CG

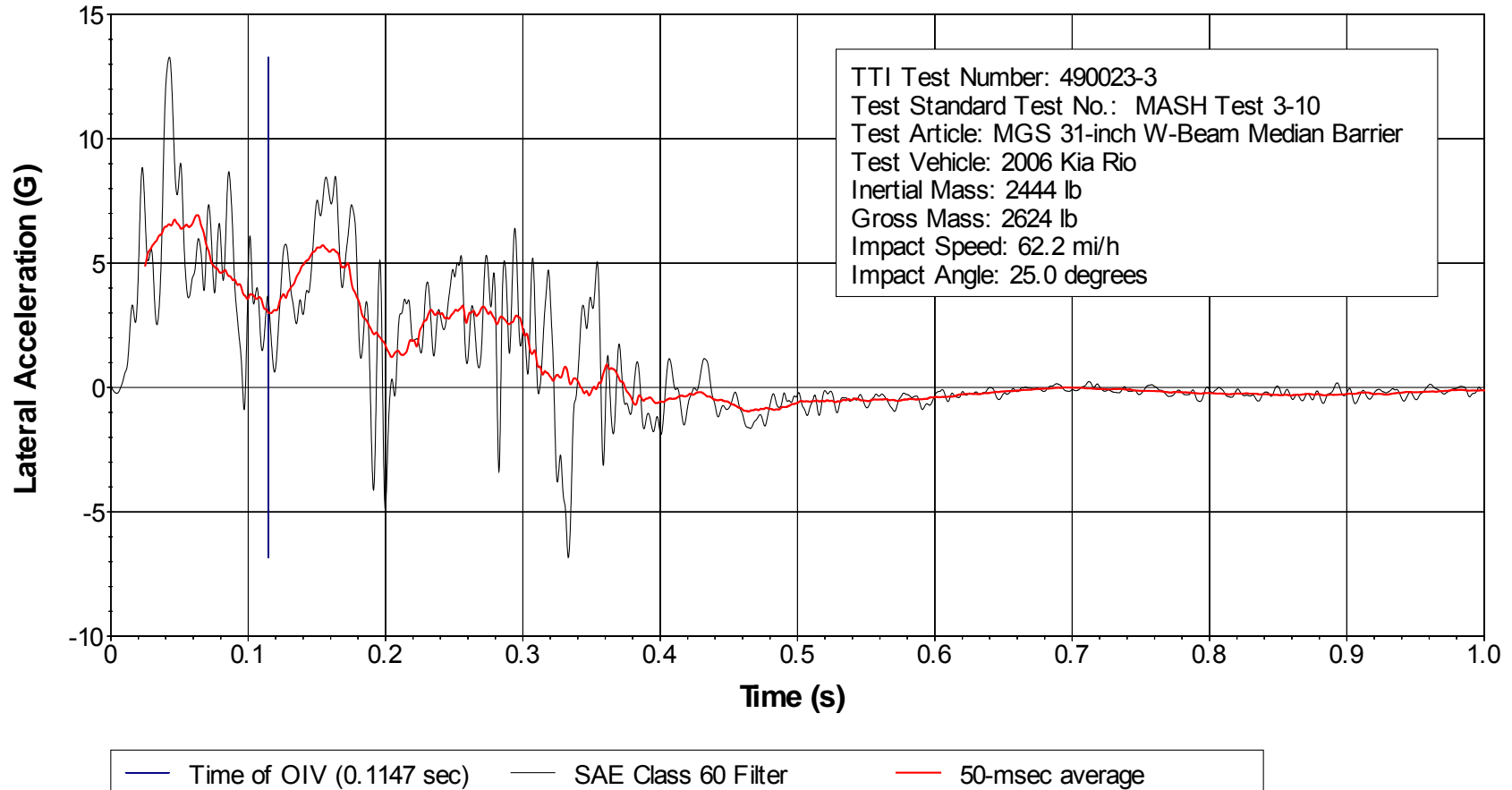

Figure D5. Vehicle Lateral Accelerometer Trace for Test No. 490023-3 (Accelerometer Located at Center of Gravity).

Z Acceleration at CG

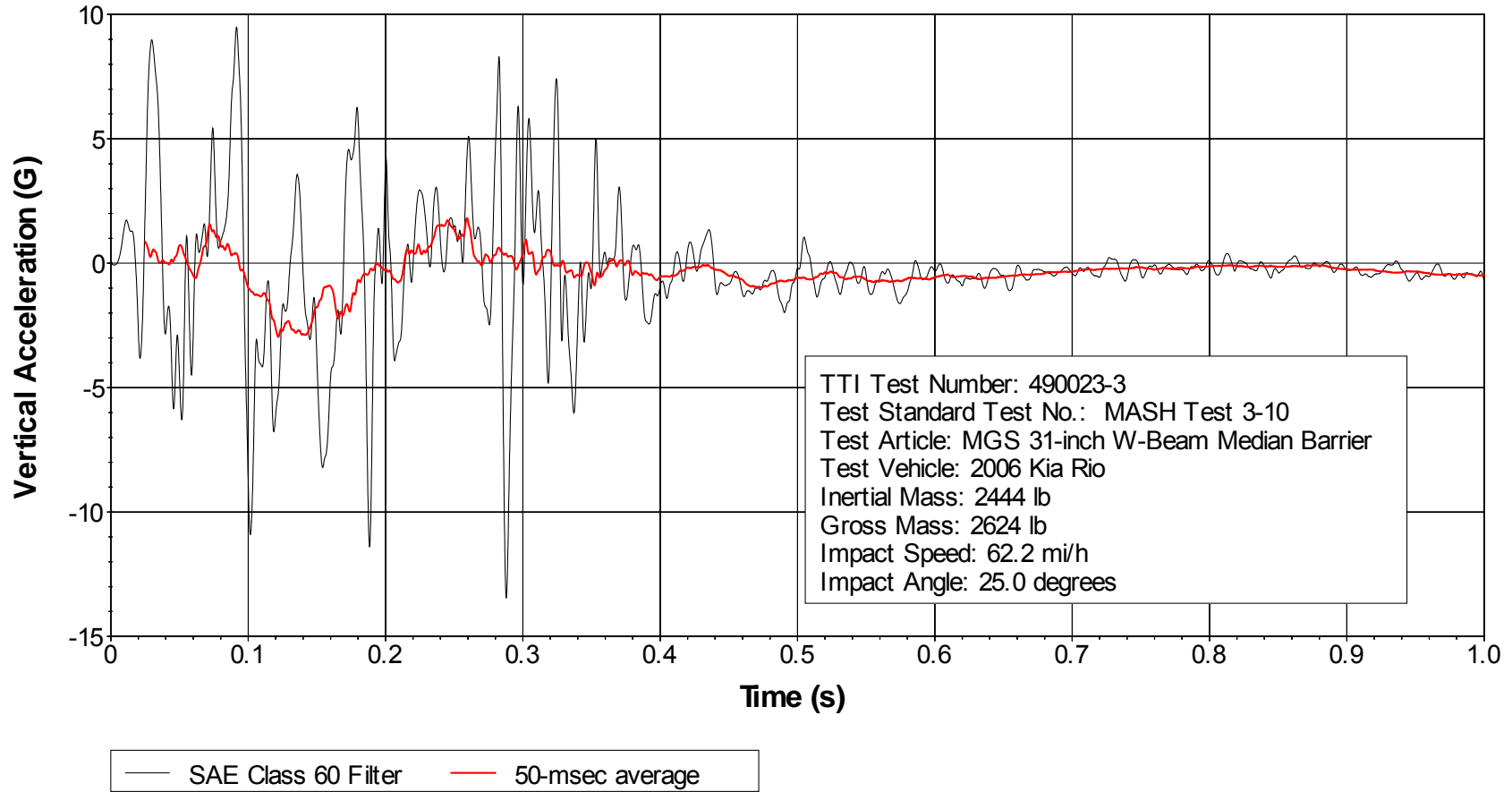

Figure D6. Vehicle Vertical Accelerometer Trace for Test No. 490023-3 (Accelerometer Located at Center of Gravity).

X Acceleration Rear of CG

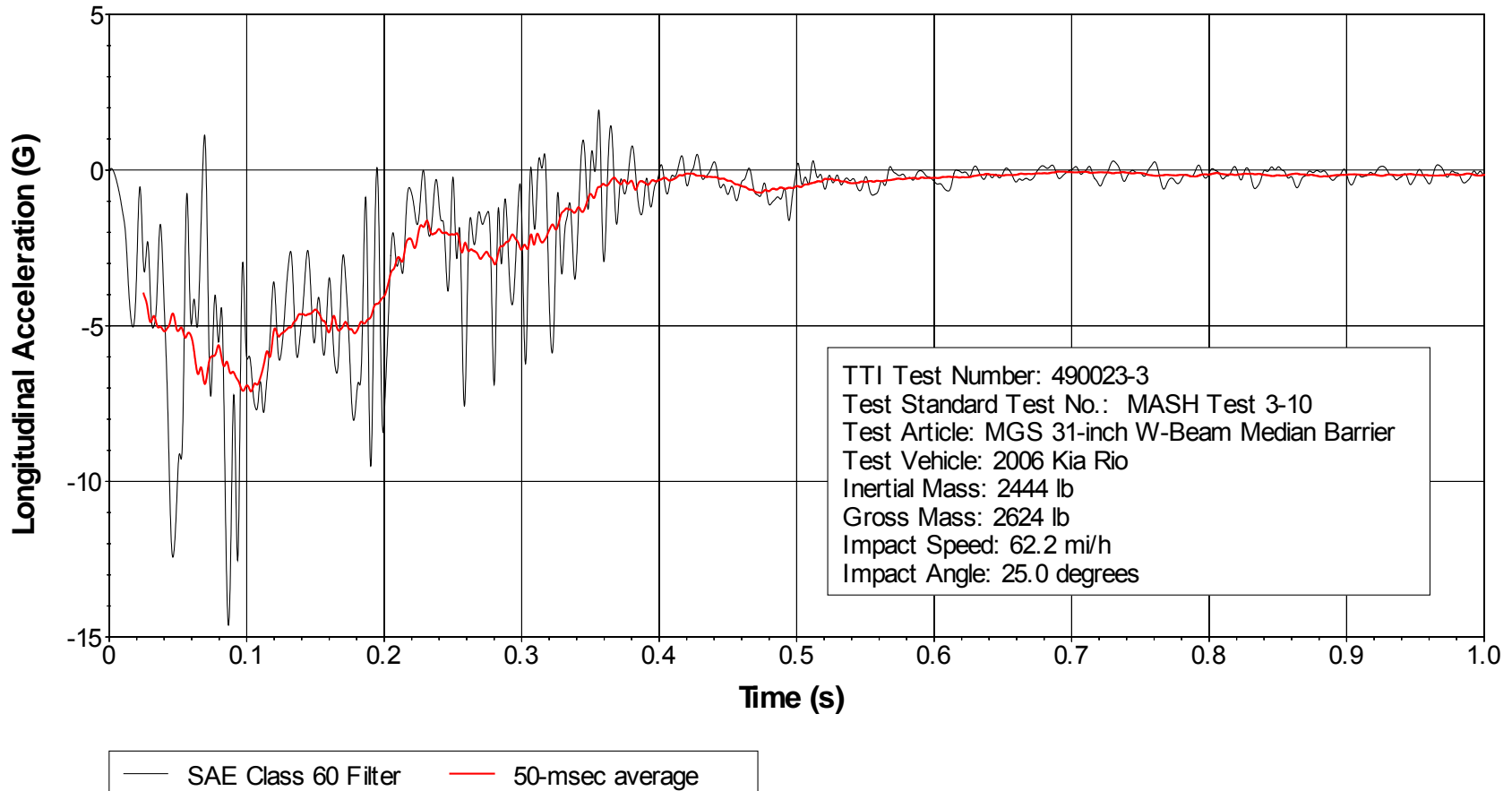

Figure D7. Vehicle Longitudinal Accelerometer Trace for Test No. 490023-3 (Accelerometer Located Rear of Center of Gravity).

Y Acceleration Rear of CG

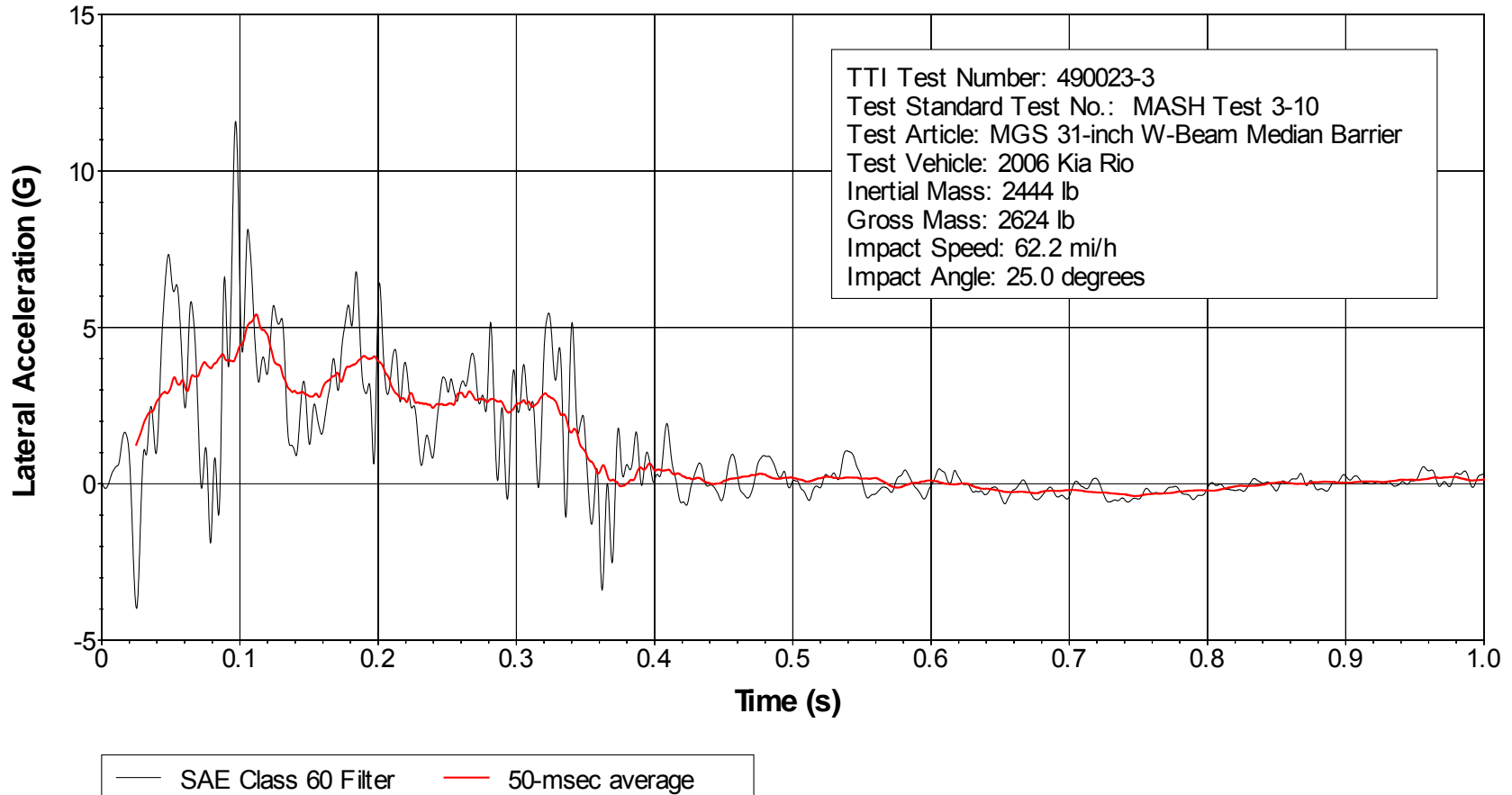

Figure D8. Vehicle Lateral Accelerometer Trace for Test No. 490023-3 (Accelerometer Located Rear of Center of Gravity).

Z Acceleration Rear of CG

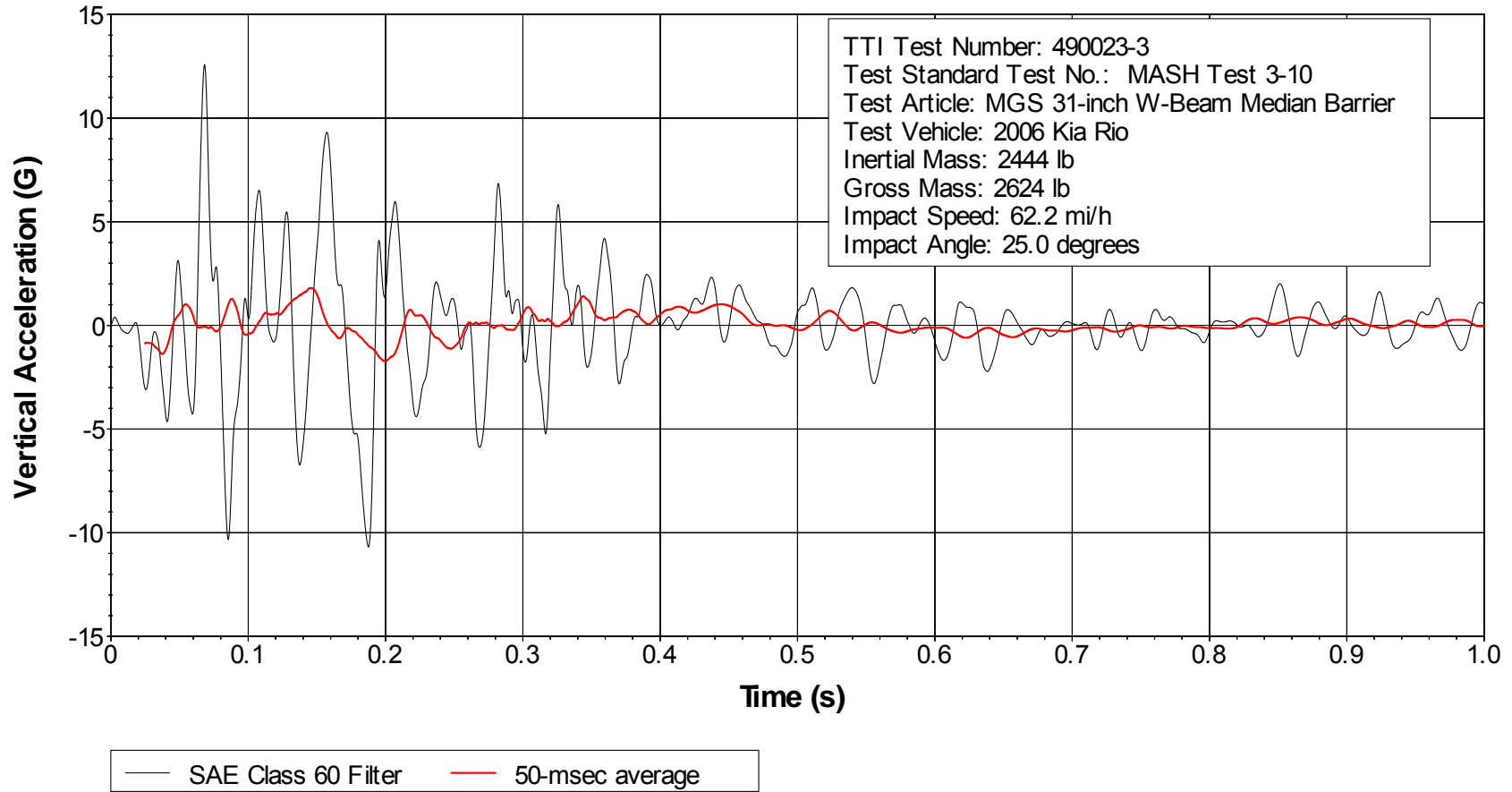

Figure D9. Vehicle Vertical Accelerometer Trace for Test No. 490023-3 (Accelerometer Located Rear of Center of Gravity).

APPENDIX E. MASH TEST 3-11 (CRASH TEST NO. 490023-4)

Table E1. Vehicle Properties for Test No. 490023-4.

Date: 2013-06-21 Test No.: 490023-4 VIN No.: 1D7HA18P975246153
 Year: 2007 Make: Dodge Model: Ram 1500
 Tire Size: 265/70R17 Tire Inflation Pressure: 35 psi
 Tread Type: _____ Odometer: 137341

Note any damage to the vehicle prior to test: _____

• Denotes accelerometer location.

NOTES: _____

Engine Type: V-8
 Engine CID: 4.7 liter

Transmission Type:
 Auto or _____ Manual
 FWD RWD 4WD

Optional Equipment: _____

Dummy Data:
 Type: No dummy
 Mass: _____
 Seat Position: _____

Geometry: inches

A	<u>78.25</u>	F	<u>36.00</u>	K	<u>20.75</u>	P	<u>3.88</u>	U	<u>28.50</u>
B	<u>75.75</u>	G	<u>28.50</u>	L	<u>29.25</u>	Q	<u>30.50</u>	V	<u>30.50</u>
C	<u>223.75</u>	H	<u>61.61</u>	M	<u>68.50</u>	R	<u>18.38</u>	W	<u>61.60</u>
D	<u>47.25</u>	I	<u>15.50</u>	N	<u>68.00</u>	S	<u>16.00</u>	X	<u>75.00</u>
E	<u>140.50</u>	J	<u>28.00</u>	O	<u>46.50</u>	T	<u>77.50</u>		
Wheel Center Height Front	<u>14.75</u>	Wheel Well Clearance (Front)	<u>6.00</u>	Bottom Frame Height - Front	<u>18.75</u>				
Wheel Center Height Rear	<u>14.75</u>	Wheel Well Clearance (Rear)	<u>11.25</u>	Bottom Frame Height - Rear	<u>26.00</u>				

GVWR Ratings:	Mass: lb	Curb	Test Inertial	Gross Static
Front	<u>3700</u>	M_{front}	<u>2817</u>	_____
Back	<u>3900</u>	M_{rear}	<u>2200</u>	_____
Total	<u>6700</u>	M_{Total}	<u>5017</u>	_____

Mass Distribution:
 lb LF: 1433 RF: 1384 LR: 1096 RR: 1104

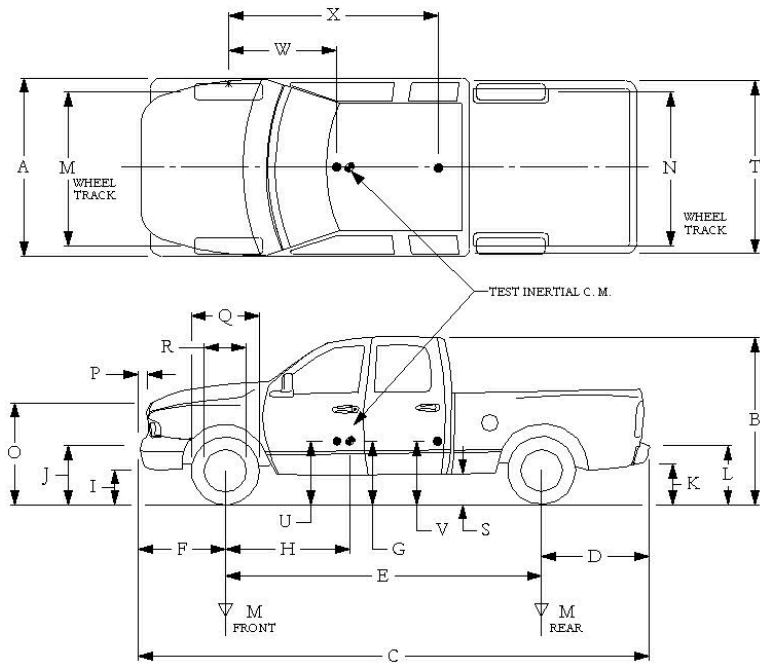

**Table E2. Parametric Measurements for Vertical CG on 2270P Vehicle
for Test No. 490023-4.**

Date: 2013-06-21 Test No.: 490023-4 VIN: 1D7HA18P975246153
 Year: 2007 Make: Dodge Model: Ram 1500
 Body Style: Quad Cab Mileage: 137341
 Engine: V-8 Transmission: Automatic
 Fuel Level: Empty Ballast: 176 lb (440 lb max)
 Tire Pressure: Front: 35 psi Rear: 35 psi Size: 265/70R17

Measured Vehicle Weights: (lb)			
LF:	<u>1433</u>	RF:	<u>1384</u>
Front Axle:		<u>2817</u>	
LR:	<u>1096</u>	RR:	<u>1104</u>
Rear Axle:		<u>2200</u>	
Left:	<u>2529</u>	Right:	<u>2488</u>
Total:		<u>5017</u>	
5000 ±110 lb allowed			
Wheel Base:	<u>140.5</u> inches	Track: F:	<u>68.5</u> inches
148 ±12 inches allowed		R:	<u>68</u> inches
		Track = (F+R)/2 = 67 ±1.5 inches allowed	
Center of Gravity, SAE J874 Suspension Method			
X:	<u>61.61</u> in	Rear of Front Axle	(63 ±4 inches allowed)
Y:	<u>-0.28</u> in	Left - Right +	of Vehicle Centerline
Z:	<u>28.5</u> in	Above Ground	(minumum 28.0 inches allowed)

Hood Height: 46.50 inches Front Bumper Height: 28.00 inches
 43 ±4 inches allowed

Front Overhang: 36.00 inches Rear Bumper Height: 29.25 inches
 39 ±3 inches allowed

Overall Length: 223.75 inches
 237 ±13 inches allowed

Table E3. Exterior Crush Measurements for Test No. 490023-4.

Date: 2013-06-21 Test No.: 490023-4 VIN No.: 1D7HA18P975246153
 Year: 2007 Make: Dodge Model: Ram 1500

VEHICLE CRUSH MEASUREMENT SHEET¹

Complete When Applicable	
End Damage	Side Damage
Undeformed end width _____ Corner shift: A1 _____ A2 _____ End shift at frame (CDC) (check one) < 4 inches _____ ≥ 4 inches _____	Bowing: B1 _____ X1 _____ B2 _____ X2 _____ Bowing constant $\frac{X1 + X2}{2} = \underline{\hspace{2cm}}$

Note: Measure C₁ to C₆ from Driver to Passenger Side in Front or Rear Impacts – Rear to Front in Side Impacts.

Specific Impact Number	Plane* of C-Measurements	Direct Damage		Field L**	C ₁	C ₂	C ₃	C ₄	C ₅	C ₆	±D
		Width** (CDC)	Max*** Crush								
1	Front plane at bumper ht	17.0	10.0	30	10	8	6.5	3	1.5	0	-15
2	Side plane above bumper	20.0	11.0	60	0	1.5	----	---	9-	11	+72
	Measurements recorded										
	in inches										

¹Table taken from National Accident Sampling System (NASS).

*Identify the plane at which the C-measurements are taken (e.g., at bumper, above bumper, at sill, above sill, at beltline, etc.) or label adjustments (e.g., free space).

Free space value is defined as the distance between the baseline and the original body contour taken at the individual C locations. This may include the following: bumper lead, bumper taper, side protrusion, side taper, etc. Record the value for each C-measurement and maximum crush.

**Measure and document on the vehicle diagram the beginning or end of the direct damage width and field L (e.g., side damage with respect to undamaged axle).

***Measure and document on the vehicle diagram the location of the maximum crush.

Note: Use as many lines/columns as necessary to describe each damage profile.

Table E4. Occupant Compartment Measurements for Test No. 490023-4.

Date: 2013-06-21 Test No.: 490023-4 VIN No.: 1D7HA18P975246153
 Year: 2007 Make: Dodge Model: Ram 1500

OCCUPANT COMPARTMENT DEFORMATION MEASUREMENT

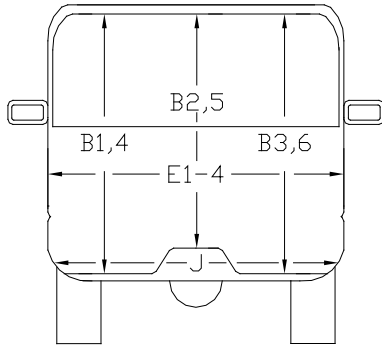
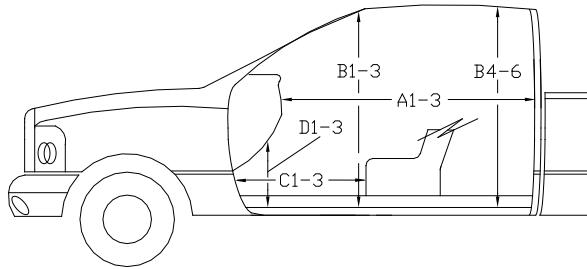
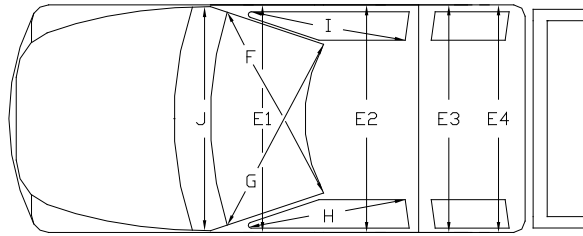

	Before (inches)	After (inches)
A1	64.50	64.50
A2	64.50	64.50
A3	65.00	65.00
B1	45.00	45.00
B2	39.25	39.25
B3	45.00	45.00
B4	42.12	42.12
B5	44.75	44.75
B6	42.12	42.12
C1	29.75	29.75
C2	----	----
C3	27.50	27.50
D1	12.75	12.75
D2	----	----
D3	11.75	11.75
E1	62.75	62.75
E2	64.50	64.50
E3	64.00	64.00
E4	64.25	64.25
F	60.00	60.00
G	60.00	60.00
H	39.00	39.00
I	39.00	39.00
J*	62.25	62.25

*Lateral area across the cab from driver's side kickpanel to passenger's side kickpanel.

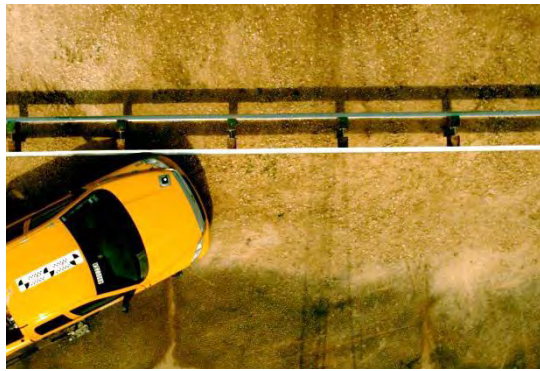

0.000 s



0.100 s



0.200 s



0.300 s



Figure E1. Sequential Photographs for Test No. 490023-4 (Overhead and Frontal Views).



0.400s



0.005 s



0.600 s



Out of View

0.700 s



Figure E1. Sequential Photographs for Test No. 490023-4 (Overhead and Frontal Views) (continued).



0.000 s



0.400 s



0.100 s



0.500 s



0.200 s



0.600 s



0.300 s



0.700 s

Figure E2. Sequential Photographs for Test No. 490023-4 (Rear View).

Roll, Pitch, and Yaw Angles

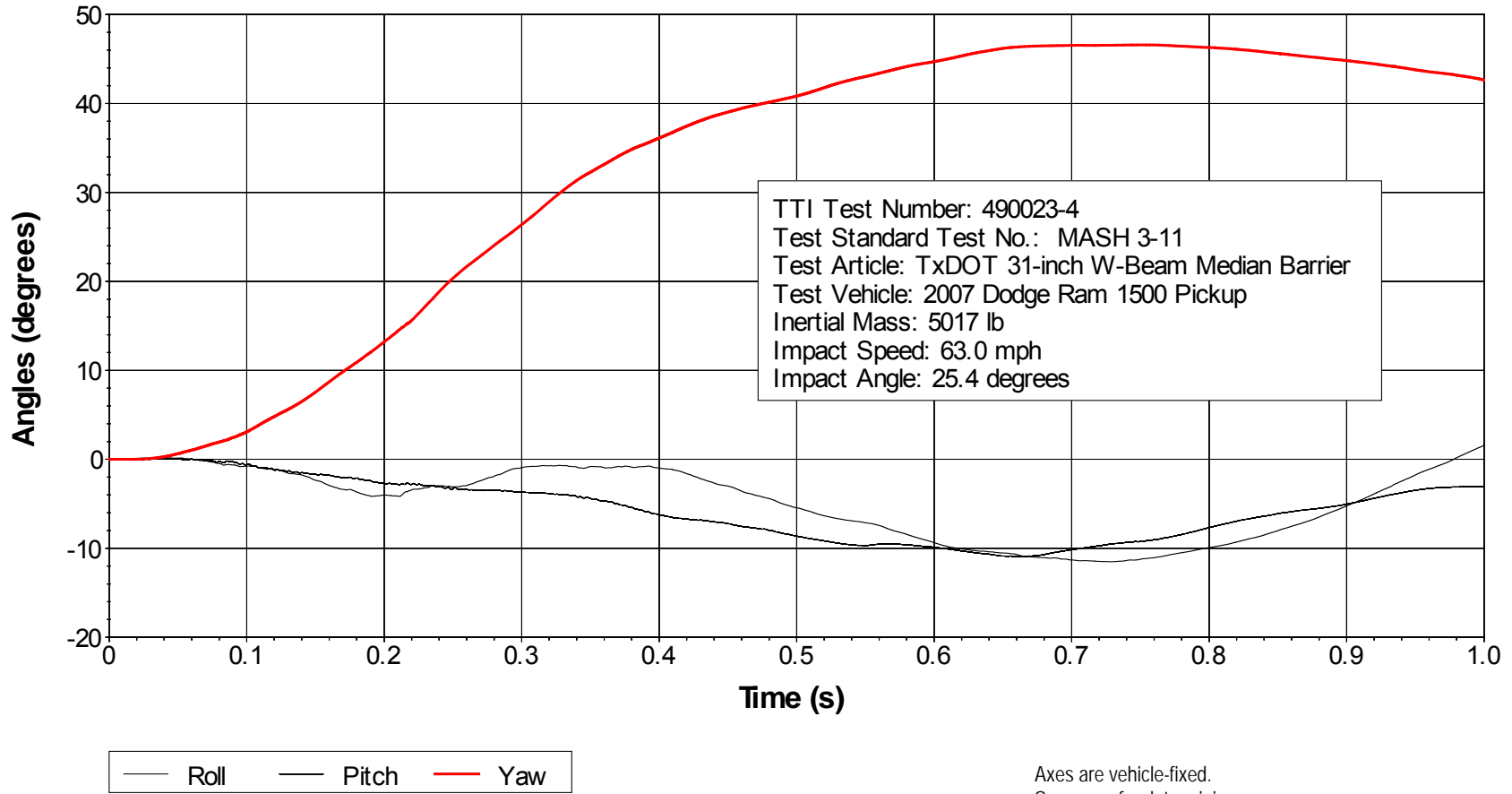

Axes are vehicle-fixed.
 Sequence for determining orientation:

1. Yaw.
2. Pitch.
3. Roll.

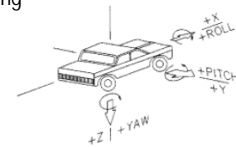

Figure E3. Vehicle Angular Displacements for Test No. 490023-4.

X Acceleration at CG

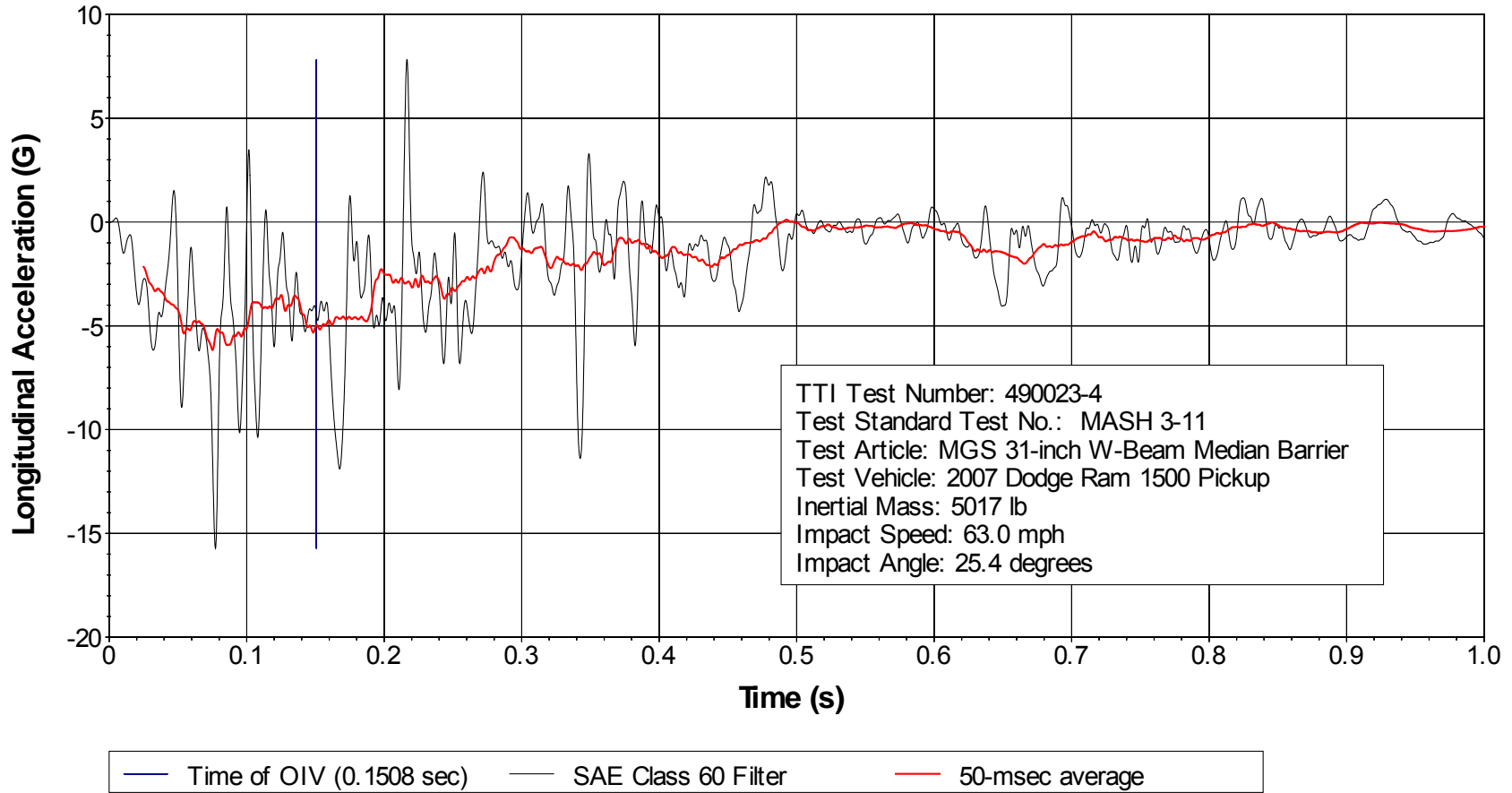

Figure E4. Vehicle Longitudinal Accelerometer Trace for Test No. 490023-4 (Accelerometer Located at Center of Gravity).

Y Acceleration at CG

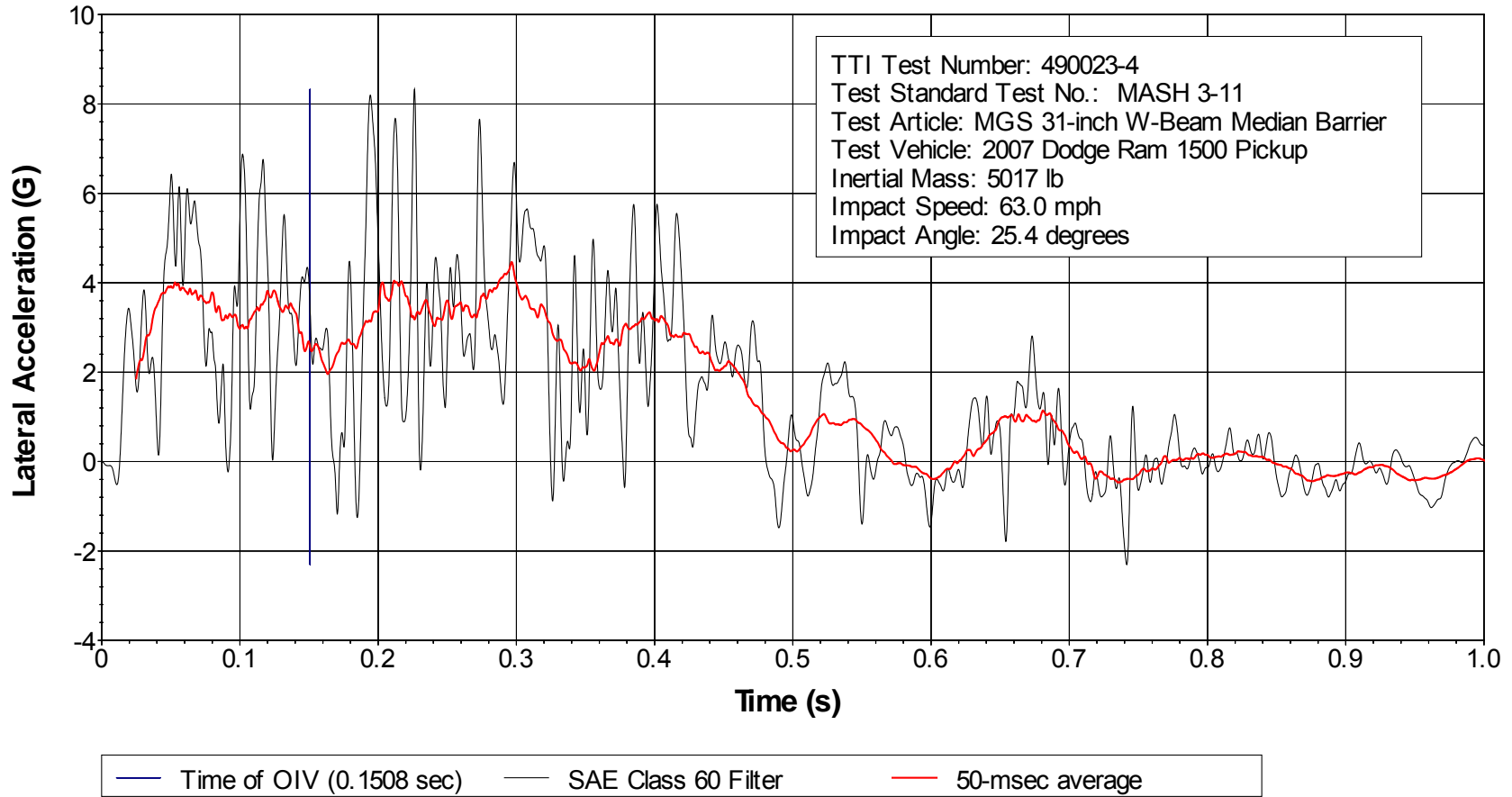

Figure E5. Vehicle Lateral Accelerometer Trace for Test No. 490023-4 (Accelerometer Located at Center of Gravity).

Z Acceleration at CG

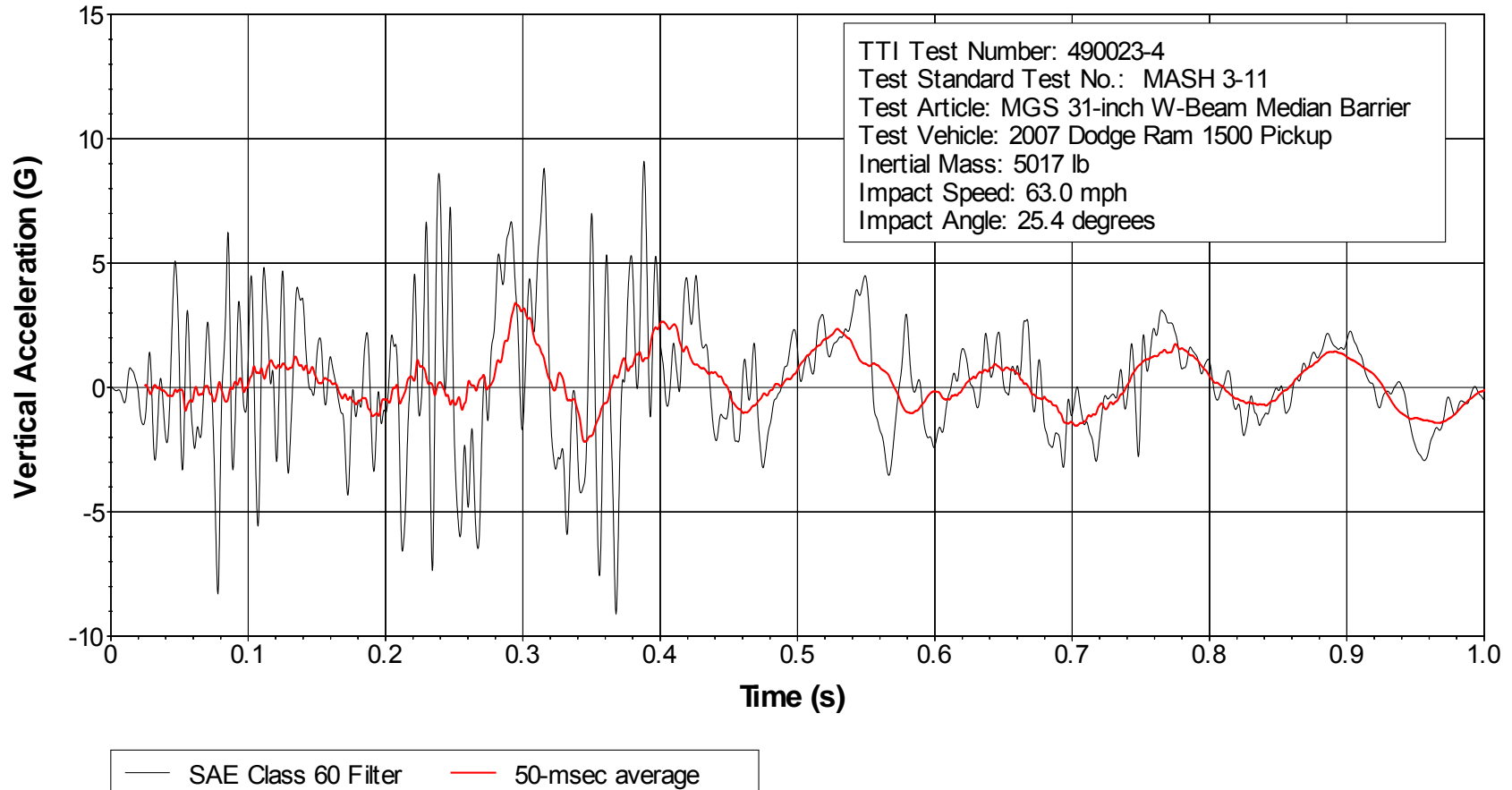

Figure E6. Vehicle Vertical Accelerometer Trace for Test No. 490023-4 (Accelerometer Located at Center of Gravity).

X Acceleration Rear of CG

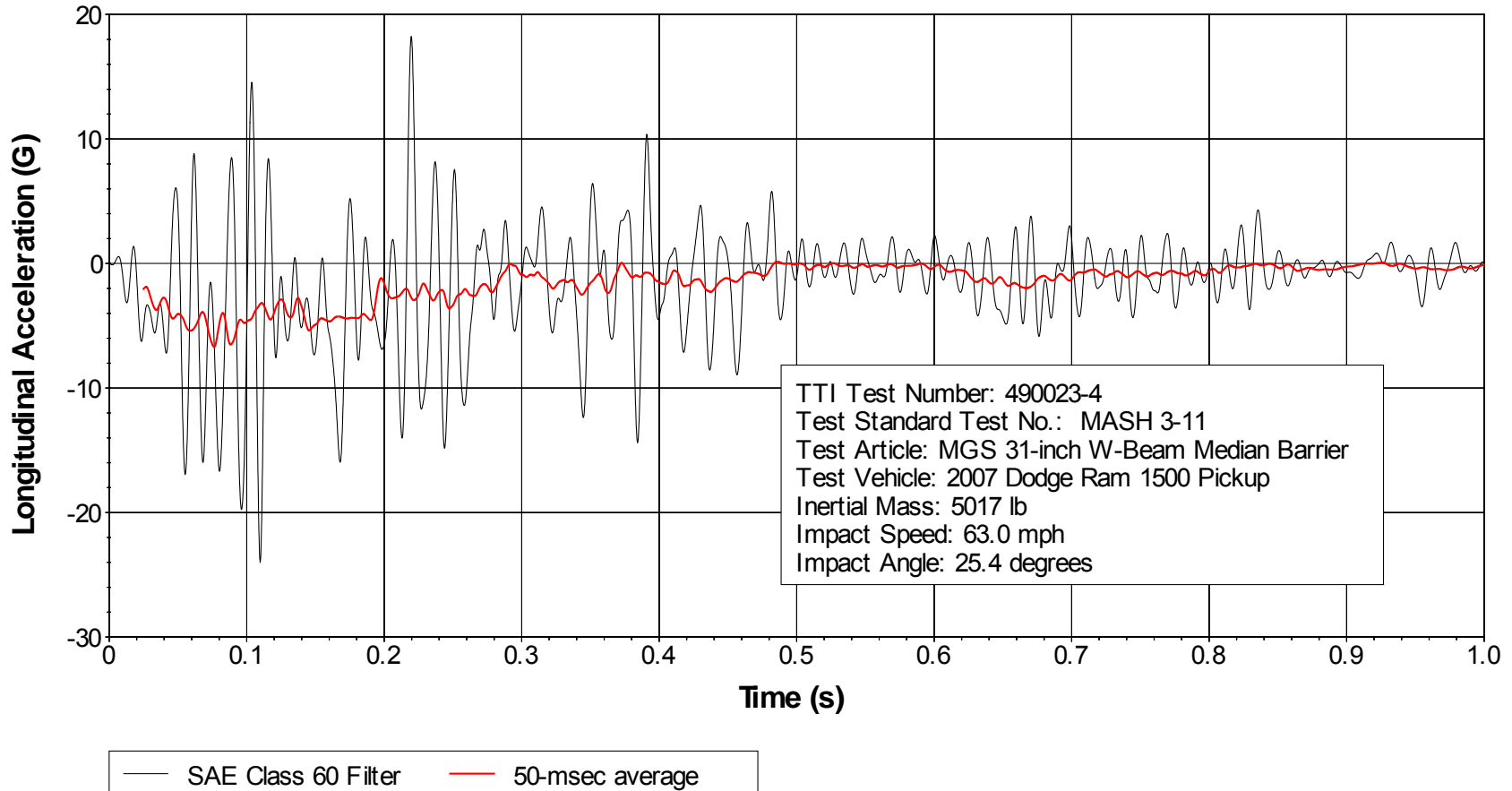

Figure E7. Vehicle Longitudinal Accelerometer Trace for Test No. 490023-4 (Accelerometer Located Rear of Center of Gravity).

Y Acceleration Rear of CG

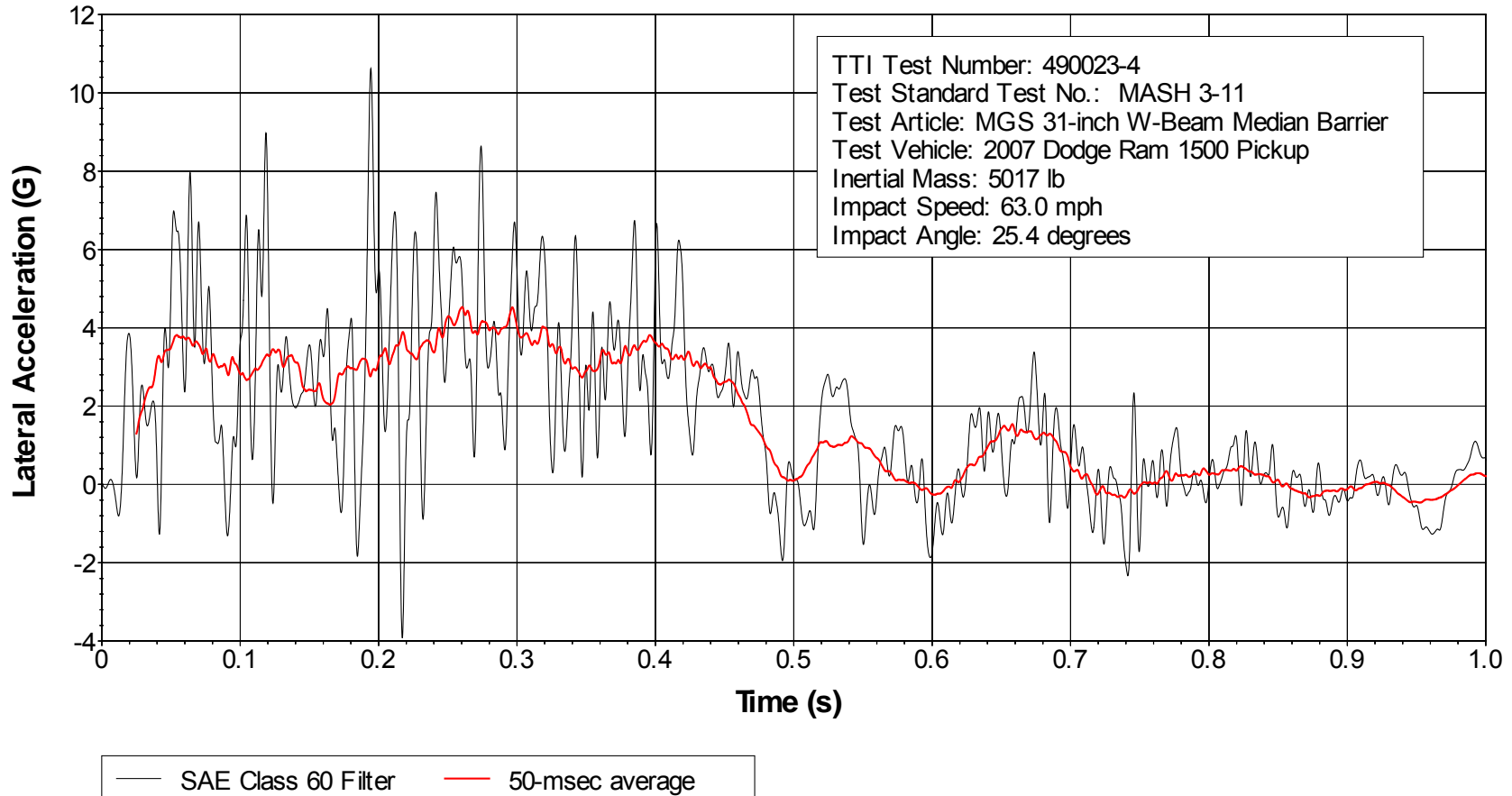

Figure E8. Vehicle Lateral Accelerometer Trace for Test No. 490023-4 (Accelerometer Located Rear of Center of Gravity).

Z Acceleration Rear of CG

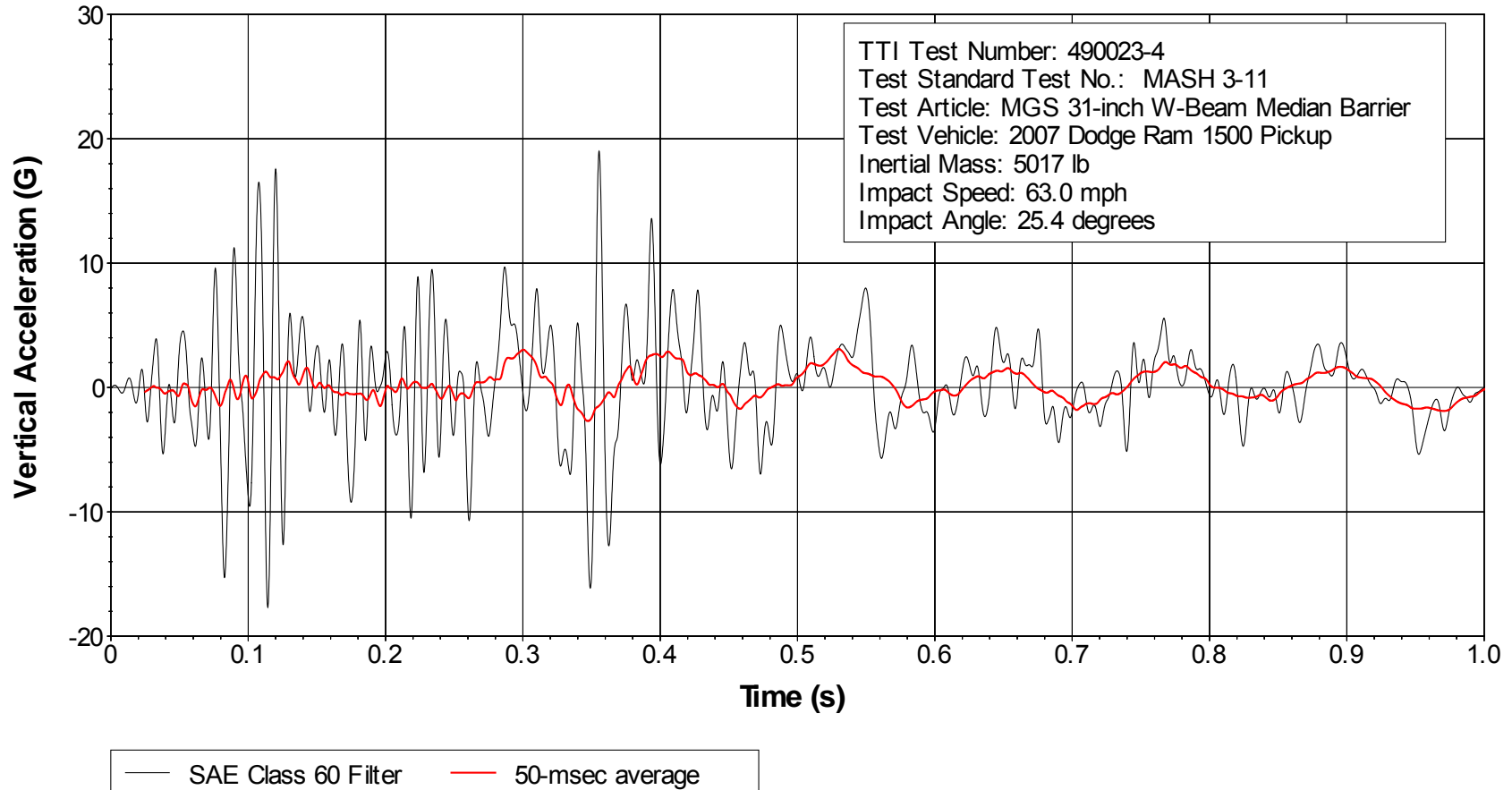

Figure E9. Vehicle Vertical Accelerometer Trace for Test No. 490023-4 (Accelerometer Located Rear of Center of Gravity).