



TESTING CERT # 2937.01

NDOR Sponsoring Agency Contract No. DPU-STWD (94)

MASH TL-4 CRASH TESTING AND EVALUATION OF THE RESTORE BARRIER

Submitted by

Jennifer D. Schmidt, Ph.D., P.E.
Research Assistant Professor

Tyler L. Schmidt, B.S.C.E.
Graduate Research Assistant

Scott K. Rosenbaugh, M.S.C.E., E.I.T.
Research Associate Engineer

Ronald K. Faller, Ph.D., P.E.
Research Associate Professor
MwRSF Director

Robert W. Bielenberg, M.S.M.E., E.I.T.
Research Associate Engineer

John D. Reid, Ph.D.
Professor

Jim C. Holloway, M.S.C.E., E.I.T.
Test Site Manager

Karla A. Lechtenberg, M.S.M.E., E.I.T.
Research Associate Engineer

MIDWEST ROADSIDE SAFETY FACILITY

Nebraska Transportation Center
University of Nebraska-Lincoln
130 Whittier Research Center
2200 Vine Street
Lincoln, Nebraska 68583-0853
(402) 472-0965

Submitted to

NEBRASKA DEPARTMENT OF ROADS
1500 Nebraska Highway 2
Lincoln, Nebraska 68502

FEDERAL HIGHWAY ADMINISTRATION
Nebraska Division
100 Centennial Mall North Room 220
Lincoln, Nebraska 68508

MwRSF Research Report No. TRP-03-318-15

November 3, 2015

TECHNICAL REPORT DOCUMENTATION PAGE

1. Report No. TRP-03-318-15	2.	3. Recipient's Accession No.	
4. Title and Subtitle MASH TL-4 Crash Testing and Evaluation of the RESTORE Barrier		5. Report Date November 3, 2015	
		6.	
7. Author(s) Schmidt, J.D., Schmidt, T.S., Rosenbaugh, S.K., Faller, R.K., Bielenberg, R.W., Reid, J.D., Holloway, J.C., and Lechtenberg, K.A.		8. Performing Organization Report No. TRP-03-318-15	
9. Performing Organization Name and Address Midwest Roadside Safety Facility (MwRSF) Nebraska Transportation Center University of Nebraska-Lincoln 130 Whittier Research Center 2200 Vine Street Lincoln, Nebraska 68583-0853		10. Project/Task/Work Unit No.	
		11. Contract © or Grant (G) No.	
12. Sponsoring Organization Name and Address Nebraska Department of Roads 1500 Nebraska Highway 2 Lincoln, Nebraska 68502 Federal Highway Administration Nebraska Division 100 Centennial Mall North Room 220 Lincoln, Nebraska 68508		13. Type of Report and Period Covered Final Report 2010 – 2015	
		14. Sponsoring Agency Code NDOR DPU-STWD (94)	
15. Supplementary Notes Prepared in cooperation with U.S. Department of Transportation, Federal Highway Administration.			
16. Abstract <p>Three full-scale vehicle crash tests were conducted according to the MASH Test Level 4 (TL-4) safety performance criteria on a restorable and reusable energy-absorbing roadside/median barrier, designated the RESTORE barrier. The system utilized for test nos. SFH-1 through SFH-3 was 240 ft (73.2 m) long with a nominal height of 38$\frac{5}{8}$ in. (981 mm). The barrier consisted of an upper steel tube rail attached to the top of 20-ft (6.1-m) long x 22$\frac{1}{4}$-in. (565-mm) wide precast concrete beams connected with wedge-shaped joints and supported by 11$\frac{1}{8}$-in. (295-mm) tall rubber posts and steel skids.</p> <p>In test no. SFH-1, a 5,021-lb (2,277-kg) pickup truck impacted the barrier at 63.4 mph (102.1 km/h) and 24.8 deg. The barrier successfully contained and redirected the vehicle. Slight spalling occurred at the impacted joint, but no structural damage occurred and the barrier fully restored. The peak lateral acceleration was reduced by up to 47 percent as compared to similar impacts on rigid barriers. In test no. SFH-2, a 2,406-lb (1,091-kg) small car impacted the same barrier at 64.3 mph (103.5 km/h) and 24.8 deg. The barrier successfully contained and redirected the vehicle. The front face of two of the rubber posts were cut by the wheel rim, which did not allow the system to fully restore. The peak lateral acceleration was reduced by up to 23 percent as compared to similar impacts on rigid barriers. In test no. SFH-3, a 21,746-lb (9,864-kg) single-unit truck impacted the same barrier as test nos. SFH-1 and SFH-2 at 56.5 mph (91.0 km/h) and 14.9 deg. The barrier successfully contained and redirected the vehicle. The front face of the barrier experienced gouging and spalling as well as cracking and spalling between five joints. Modifications were recommended to strengthen the concrete at the joints to prevent spalling and to mitigate wheel interaction with the posts.</p>			
17. Document Analysis/Descriptors Highway Safety, Crash Test, Roadside Appurtenances, Compliance Test, MASH, Test Level 4, Energy-Absorbing Barrier, Low Maintenance, Rubber Posts, Concrete Barrier, RESTORE		18. Availability Statement No restrictions. Document available from: National Technical Information Services, Springfield, Virginia 22161	
19. Security Class (this report) Unclassified	20. Security Class (this page) Unclassified	21. No. of Pages 295	22. Price

DISCLAIMER STATEMENT

This report was completed with funding from the Federal Highway Administration, U.S. Department of Transportation. The contents of this report reflect the views and opinions of the authors who are responsible for the facts and the accuracy of the data presented herein. The contents do not necessarily reflect the official views or policies of the Nebraska Department of Roads nor the Federal Highway Administration, U.S. Department of Transportation. This report does not constitute a standard, specification, regulation, product endorsement, or an endorsement of manufacturers.

UNCERTAINTY OF MEASUREMENT STATEMENT

The Midwest Roadside Safety Facility (MwRSF) has determined the uncertainty of measurements for several parameters involved in standard full-scale crash testing and non-standard testing of roadside safety features. Information regarding the uncertainty of measurements for critical parameters is available upon request by the sponsor and the Federal Highway Administration.

INDEPENDENT APPROVING AUTHORITY

The Independent Approving Authority (IAA) for the data contained herein was Dr. Cody Stolle, Research Assistant Professor.

ACKNOWLEDGEMENTS

The authors wish to acknowledge several sources that made a contribution to this project:

(1) the Federal Highway Administration and the Nebraska Department of Roads for sponsoring this project; (2) Concrete Industries, Inc. for providing support and guidance in the design and fabrication of the concrete barriers; and (3) MwRSF personnel for constructing the system and conducting the crash tests.

Acknowledgement is also given to the following individuals who made a contribution to the completion of this research project.

Midwest Roadside Safety Facility

K.L. Krenk, B.S.M.A., former Maintenance Mechanic
S.M. Tighe, Laboratory Mechanic
A.T. Russell, B.S.B.A., Shop Manager
D.S. Charroin, Laboratory Mechanic
M.A. Rasmussen, Laboratory Mechanic
E.W. Krier, Laboratory Mechanic
Undergraduate and Graduate Research Assistants

Nebraska Department of Roads

Phil TenHulzen, P.E., Design Standards Engineer
Jim Knott, P.E., State Roadway Design Engineer
Jodi Gibson, Research Coordinator

Federal Highway Administration

John Perry, P.E., Nebraska Division Office
Danny Briggs, Nebraska Division Office

TABLE OF CONTENTS

TECHNICAL REPORT DOCUMENTATION PAGE i

DISCLAIMER STATEMENT ii

UNCERTAINTY OF MEASUREMENT STATEMENT ii

INDEPENDENT APPROVING AUTHORITY..... ii

ACKNOWLEDGEMENTS iii

TABLE OF CONTENTS..... iv

LIST OF FIGURES vi

LIST OF TABLES xii

1 INTRODUCTION 1

 1.1 Background 1

 1.2 Objective 3

 1.3 Scope..... 3

2 DESIGN DETAILS TEST NOS. SFH-1 AND SFH-2..... 5

3 TEST REQUIREMENTS AND EVALUATION CRITERIA 34

 3.1 Test Requirements 34

 3.2 Evaluation Criteria 34

4 TEST CONDITIONS..... 37

 4.1 Test Facility 37

 4.2 Vehicle Tow and Guidance System 37

 4.3 Test Vehicles..... 37

 4.4 Simulated Occupant 50

 4.5 Data Acquisition Systems 50

 4.5.1 Accelerometers 50

 4.5.2 Rate Transducers..... 53

 4.5.3 Load Cells 54

 4.5.4 Retroreflective Optic Speed Trap 54

 4.5.5 Digital Photography 55

5 FULL-SCALE CRASH TEST NO. SFH-1 59

 5.1 Test No. SFH-1 59

 5.2 Weather Conditions 59

 5.3 Test Description 59

 5.4 Barrier Damage..... 60

 5.5 Vehicle Damage..... 62

 5.6 Occupant Risk..... 63

 5.7 2270P Comparison to Rigid Barrier Tests 79

5.8 Discussion 85

6 FULL-SCALE CRASH TEST NO. SFH-2 86

 6.1 Test No. SFH-2 86

 6.2 Weather Conditions 86

 6.3 Test Description 86

 6.4 Barrier Damage 87

 6.5 Vehicle Damage 89

 6.6 Occupant Risk 90

 6.7 1100C Comparison to Rigid Barrier Tests 107

 6.8 Discussion 113

7 DESIGN DETAILS, TEST NO. SFH-3 114

8 FULL-SCALE CRASH TEST NO. SFH-3 139

 8.1 Weathering of the Barrier 139

 8.2 Test No. SFH-3 139

 8.3 Weather Conditions 140

 8.4 Test Description 140

 8.5 Barrier Damage 141

 8.6 Vehicle Damage 144

 8.7 Occupant Risk 145

 8.8 10000S Peak Lateral Force Calculation 167

 8.9 Discussion 167

9 SUMMARY, CONCLUSIONS, AND RECOMMENDATIONS 169

10 REFERENCES 175

11 APPENDICES 177

 Appendix A. Material Specifications 178

 Appendix B. Vehicle Center of Gravity Determination 214

 Appendix C. Vehicle Deformation Records 218

 Appendix D. Accelerometer and Rate Transducer Data Plots, Test No. SFH-1 236

 Appendix E. Accelerometer and Rate Transducer Data Plots, Test No. SFH-2 253

 Appendix F. Accelerometer and Rate Transducer Data Plots, Test No. SFH-3 270

LIST OF FIGURES

Figure 1. View of Initial Concept with Rubber Posts and Metal Skids [3]	3
Figure 2. Test Installation Layout, Test No. SFH-1	7
Figure 3. Barrier Assembly, Test Nos. SFH-1 and SFH-2	8
Figure 4. Post and Tubing Details, Test Nos. SFH-1 and SFH-2	9
Figure 5. Splice Details, Test Nos. SFH-1 and SFH-2	10
Figure 6. Splice 5-6 Instrumentation Details, Test No. SFH-1	11
Figure 7. Concrete Beam Geometry, Test Nos. SFH-1 and SFH-2	12
Figure 8. Concrete Beam Details, Test Nos. SFH-1 and SFH-2	13
Figure 9. Concrete Beam and Rebar Assembly, Test Nos. SFH-1 and SFH-2	14
Figure 10. Concrete Beam, Rebar Assembly Details, Test Nos. SFH-1 and SFH-2	15
Figure 11. Concrete Beam, Rebar Assembly Details, Test Nos. SFH-1 and SFH-2	16
Figure 12. Concrete Beam, Rebar Assembly Details, Test Nos. SFH-1 and SFH-2	17
Figure 13. Bill of Bars, Test Nos. SFH-1 and SFH-2	18
Figure 14. Skid Details, Test Nos. SFH-1 and SFH-2	19
Figure 15. Skid Assembly Details, Test Nos. SFH-1 and SFH-2	20
Figure 16. Skid Component Details, Test Nos. SFH-1 and SFH-2	21
Figure 17. Skid Top Plate Detail, Test Nos. SFH-1 and SFH-2	22
Figure 18. Upper Tube Assembly, Test Nos. SFH-1 and SFH-2	23
Figure 19. Steel End Tubing Assembly, Test Nos. SFH-1 and SFH-2	24
Figure 20. Steel Tubing Components, Test Nos. SFH-1 and SFH-2	25
Figure 21. Angle Joint Details, Test Nos. SFH-1 and SFH-2	26
Figure 22. Rubber Post Details, Test Nos. SFH-1 and SFH-2	27
Figure 23. Fastener Details, Test Nos. SFH-1 and SFH-2	28
Figure 24. Bill of Materials, Test Nos. SFH-1 and SFH-2	29
Figure 25. System Layout, Test No. SFH-2	30
Figure 26. Test Installation Photographs, Test Nos. SFH-1 through SFH-2	31
Figure 27. Test Installation Photographs, Adjustable Continuity Joint, Test Nos. SFH-1 through SFH-2	32
Figure 28. Test Installation Photographs, Skids and Upper Tube Assembly Splices, Test Nos. SFH-1 through SFH-2	33
Figure 29. Test Vehicle, Test No. SFH-1	40
Figure 30. Vehicle Dimensions, Test No. SFH-1	41
Figure 31. Test Vehicle, Test No. SFH-2	42
Figure 32. Vehicle Dimensions, Test No. SFH-2	43
Figure 33. Test Vehicle, Test No. SFH-3	44
Figure 34. Vehicle Dimensions, Test No. SFH-3	45
Figure 35. Target Geometry, Test No. SFH-1	46
Figure 36. Target Geometry, Test No. SFH-2	47
Figure 37. Target Geometry, Test No. SFH-3	48
Figure 38. Shear Plate and U-Bolt Installation, Test No. SFH-3	51
Figure 39. Ballast Installation, Test No. SFH-3	52
Figure 40. Camera Locations, Speeds, and Lens Settings, Test No. SFH-1	56
Figure 41. Camera Locations, Speeds, and Lens Settings, Test No. SFH-2	57
Figure 42. Camera Locations, Speeds, and Lens Settings, Test No. SFH-3	58
Figure 43. Summary of Test Results and Sequential Photographs, Test No. SFH-1	66

Figure 44. Additional Sequential Photographs, Test No. SFH-1	67
Figure 45. Additional Sequential Photographs, Test No. SFH-1	68
Figure 46. Additional Sequential Photographs, Test No. SFH-1	69
Figure 47. Additional Sequential Photographs, Test No. SFH-1	70
Figure 48. Documentary Photographs, Test No. SFH-1	71
Figure 49. Documentary Photographs, Test No. SFH-1	72
Figure 50. Impact Location, Test No. SFH-1	73
Figure 51. Vehicle Final Position and Trajectory Marks, Test No. SFH-1	74
Figure 52. System Damage, Barrier Nos. 5 and 6, Test No. SFH-1	75
Figure 53. System Damage, Post Contact Marks Under Barrier No. 6, Test No. SFH-1	76
Figure 54. Vehicle Damage, Left Side, Test No. SFH-1	77
Figure 55. Vehicle Damage, Left-Front and Left-Rear Tires, Test No. SFH-1	78
Figure 56. Perpendicular Impact Forces Imparted to the Barrier System, Test No. SFH-1	81
Figure 57. Force Comparisons, 2270P Vehicle	82
Figure 58. Lateral Acceleration Comparison, 2270P Vehicles	83
Figure 59. Longitudinal Acceleration Comparison, 2270P Vehicles	84
Figure 60. Summary of Test Results and Sequential Photographs, Test No. SFH-2	92
Figure 61. Additional Sequential Photographs, Test No. SFH-2	93
Figure 62. Additional Sequential Photographs, Test No. SFH-2	94
Figure 63. Additional Sequential Photographs, Test No. SFH-2	95
Figure 64. Documentary Photographs, Test No. SFH-2	96
Figure 65. Documentary Photographs, Test No. SFH-2	97
Figure 66. Documentary Photographs, Test No. SFH-2	98
Figure 67. Impact Location, Test No. SFH-2	99
Figure 68. Vehicle Final Position and Trajectory Marks, Test No. SFH-2	100
Figure 69. System Damage, Barrier No. 7, Test No. SFH-2	101
Figure 70. System Damage, Barrier No. 8, Test No. SFH-2	102
Figure 71. System Damage, Rubber Post Damage, Barrier No. 8, Test No. SFH-2	103
Figure 72. System Damage, Barrier Nos. 11 and 12, Test No. SFH-2	104
Figure 73. Vehicle Damage, Test No. SFH-2	105
Figure 74. Vehicle Damage, Test No. SFH-2	106
Figure 75. Perpendicular Forces Imparted to the Barrier System, Test No. SFH-2	109
Figure 76. Force Comparisons, 1100C Vehicle	110
Figure 77. Lateral Acceleration Comparison, 1100C Vehicle	111
Figure 78. Longitudinal Acceleration Comparison, 1100C Vehicle	112
Figure 79. System Layout, Test No. SFH-3	115
Figure 80. Barrier Assembly, Test No. SFH-3	116
Figure 81. Post and Tubing Details, Test No. SFH-3	117
Figure 82. Splice Details, Test No. SFH-3	118
Figure 83. Splice 5-6 Instrumentation Details, Test No. SFH-3	119
Figure 84. Concrete Beam Geometry, Test No. SFH-3	120
Figure 85. Concrete Beam Details, Test No. SFH-3	121
Figure 86. Concrete Beam and Rebar Assembly, Test No. SFH-3	122
Figure 87. Concrete Beam, Rebar Assembly Details, Test No. SFH-3	123
Figure 88. Concrete Beam, Rebar Assembly Details, Test No. SFH-3	124
Figure 89. Concrete Beam, Rebar Assembly Details, Test No. SFH-3	125
Figure 90. Bill of Bars, Test No. SFH-3	126

Figure 91. Skid Details, Test No. SFH-3	127
Figure 92. Skid Assembly Details, Test No. SFH-3	128
Figure 93. Skid Component Details, Test No. SFH-3	129
Figure 94. Skid Top Plate Detail, Test No. SFH-3	130
Figure 95. Upper Tube Assembly, Test No. SFH-3	131
Figure 96. Steel End Tubing Assembly, Test No. SFH-3.....	132
Figure 97. Steel Tubing Components, Test No. SFH-3.....	133
Figure 98. Angle Joint Details, Test No. SFH-3.....	134
Figure 99. Rubber Post Details, Test No. SFH-3.....	135
Figure 100. Fastener Details, Test No. SFH-3.....	136
Figure 101. Bill of Materials, Test No. SFH-3	137
Figure 102. Upper Rail Assembly thru Bolt Connection, Test No. SFH-3	138
Figure 103. Concrete Beam Cracks Due to Freeze-Thaw	139
Figure 104. Summary of Test Results and Sequential Photographs, Test No. SFH-3	147
Figure 105. Additional Sequential Photographs, Test No. SFH-3.....	148
Figure 106. Additional Sequential Photographs, Test No. SFH-3.....	149
Figure 107. Documentary Photographs, Test No. SFH-3	150
Figure 108. Documentary Photographs, Test No. SFH-3	151
Figure 109. Impact Location, Test No. SFH-3	152
Figure 110. Vehicle Final Position and Trajectory Marks, Test No. SFH-3	153
Figure 111. System Damage, Barrier No. 5 and Joint Between Barrier Nos. 5 and 6, Test No. SFH-3	154
Figure 112. System Damage, Post Contact and Joint between Barrier Nos. 5 and 6, Test No. SFH-3	155
Figure 113. System Damage, Barrier No. 6, Test No. SFH-3	156
Figure 114. System Damage, Joint between Barrier Nos. 6 and 7, Test No. SFH-3.....	157
Figure 115. System Damage, First Upper Tube Assembly Connection Upstream from Joint between Barrier Nos. 6 and 7, Test No. SFH-3	158
Figure 116. System Damage, Upper Tube Assembly Connection Damage, Barrier No. 7, Test No. SFH-3	159
Figure 117. System Damage, Barrier No. 8, Test No. SFH-3	160
Figure 118. System Damage, Joint Damage, Barrier Nos. 5 and 6, Disassembled, Test No. SFH-3.....	161
Figure 119. System Damage, Joint Damage, Barrier Nos. 7 and 8, Disassembled, Test No. SFH-3.....	162
Figure 120. System Damage, Joint Damage, Barrier Nos. 4 and 9, Disassembled, Test No. SFH-3.....	163
Figure 121. Vehicle Damage, Test No. SFH-3.....	164
Figure 122. Vehicle Damage, Shear Plate Damage, Test No. SFH-3	165
Figure 123. Vehicle Damage, Test No. SFH-3	166
Figure 124. Perpendicular Forces Imparted to the Barrier System, Test No. SFH-3	168
Figure A-1. Rubber Post, Test Nos. SFH-1 through SFH-3	183
Figure A-2. Top Steel Beam Supporting Posts, Test Nos. SFH-1 through SFH-3.....	184
Figure A-3. Top Steel Beam, Test Nos. SFH-1 through SFH-3.....	185
Figure A-4. Upper Steel Tube Mounting Plate, Test Nos. SFH-1 through SFH-3.....	186
Figure A-5. 3/4-in. (19-mm) Diameter Flat Washer, Test Nos. SFH-1 through SFH-3.....	187
Figure A-6. 3/4-in. (19-mm) Diameter Threaded Rod, Test Nos. SFH-1 and SFH-2	188

Figure A-7. 3/4-in. (19-mm) Diameter Threaded Rod, Test No. SFH-3	189
Figure A-8. 3/4-in. (19-mm) Diameter Hex Bolt, Test No. SFH-3	190
Figure A-9. 3/4-in. (19-mm) Diameter Hex Nut, Test Nos. SFH-1 through SFH-3.....	191
Figure A-10. 1-in. (25-mm) Hex Head Bolt, Test Nos. SFH-1 through SFH-3	192
Figure A-11. 3/4-in. (19-mm) Diameter Flat Washer, Test Nos. SFH-1 through SFH-3.....	193
Figure A-12. 1/2-in. (13-mm) Diameter Nut, Test Nos. SFH-1 through SFH-3	194
Figure A-13. 1/2-in. (13-mm) Diameter Nut, Test Nos. SFH-1 through SFH-3	195
Figure A-14. 1-in. (25-mm) Diameter Hex Head Bolt, Test Nos. SFH-1 through SFH-3	196
Figure A-15. 1-in. (25-mm) Diameter Hex Head Bolt, Test Nos. SFH-1 through SFH-3	197
Figure A-16. 3/4-in. (19-mm) Hex Nut, Test Nos. SFH-1 through SFH-3	198
Figure A-17. Concrete Beam, Test Nos. SFH-1 through SFH-3	199
Figure A-18. Concrete Beam, Test Nos. SFH-1 through SFH-3	200
Figure A-19. Concrete Beam, Test Nos. SFH-1 through SFH-3	201
Figure A-20. Concrete Beam, Test Nos. SFH-1 through SFH-3	202
Figure A-21. Skid Steel Tube, Test Nos. SFH-1 through SFH-3	203
Figure A-22. Rubber Padding For Skid, Test Nos. SFH-1 through SFH-3	204
Figure A-23. L-Bracket for ACJ, Test Nos. SFH-1 through SFH-3.....	205
Figure A-24. Bent Plate, Test Nos. SFH-1 through SFH-3	206
Figure A-25. Top Plate on Skid, Test Nos. SFH-1 through SFH-3	207
Figure A-26. Base Plate on Skid, Test Nos. SFH-1 through SFH-3.....	208
Figure A-27. Skid Gusset Plate, Test Nos. SFH-1 through SFH-3.....	209
Figure A-28. Long-Bent Rebar, Test Nos. SFH-1 through SFH-3	210
Figure A-29. Long-Bent Rebar, Test Nos. SFH-1 through SFH-3	211
Figure A-30. Concrete Beam Reinforcement, Test Nos. SFH-1 through SFH-3	212
Figure A-31. Concrete Beam Reinforcement, Test Nos. SFH-1 through SFH-3	213
Figure B-1. Vehicle Mass Distribution, Test No. SFH-1	215
Figure B-2. Vehicle Mass Distribution, Test No. SFH-2	216
Figure B-3. Vehicle Mass Distribution, Test No. SFH-3	217
Figure C-1. Floorpan Deformation Data – Set 1, Test No. SFH-1	219
Figure C-2. Floorpan Deformation Data – Set 2, Test No. SFH-1	220
Figure C-3. Occupant Compartment Deformation Data – Set 1, Test No. SFH-1	221
Figure C-4. Occupant Compartment Deformation Data – Set 2, Test No. SFH-1	222
Figure C-5. Exterior Vehicle Crush (NASS) - Front, Test No. SFH-1	223
Figure C-6. Exterior Vehicle Crush (NASS) - Side, Test No. SFH-1	224
Figure C-7. Floorpan Deformation Data – Set 1, Test No. SFH-2	225
Figure C-8. Floorpan Deformation Data – Set 2, Test No. SFH-2	226
Figure C-9. Occupant Compartment Deformation Data – Set 1, Test No. SFH-2	227
Figure C-10. Occupant Compartment Deformation Data – Set 2, Test No. SFH-2	228
Figure C-11. Occupant Compartment Deformation Data – Roof Crush, Test No. SFH-2.....	229
Figure C-12. Exterior Vehicle Crush (NASS) - Front, Test No. SFH-2.....	230
Figure C-13. Exterior Vehicle Crush (NASS) - Side, Test No. SFH-2	231
Figure C-14. Floorpan Deformation Data – Set 1, Test No. SFH-3	232
Figure C-15. Floorpan Deformation Data – Set 2, Test No. SFH-3	233
Figure C-16. Occupant Compartment Deformation Data – Set 1, Test No. SFH-3	234
Figure C-17. Occupant Compartment Deformation Data – Set 2, Test No. SFH-3	235
Figure D-1. 10-ms Average Longitudinal Deceleration (SLICE-1), Test No. SFH-1.....	237
Figure D-2. Longitudinal Occupant Impact Velocity (SLICE-1), Test No. SFH-1	238

Figure D-3. Longitudinal Occupant Displacement (SLICE-1), Test No. SFH-1	239
Figure D-4. 10-ms Average Lateral Deceleration (SLICE-1), Test No. SFH-1	240
Figure D-5. Lateral Occupant Impact Velocity (SLICE-1), Test No. SFH-1	241
Figure D-6. Lateral Occupant Displacement (SLICE-1), Test No. SFH-1	242
Figure D-7. Vehicle Angular Displacements (SLICE-1), Test No. SFH-1	243
Figure D-8. Acceleration Severity Index (SLICE-1), Test No. SFH-1	244
Figure D-9. 10-ms Average Longitudinal Deceleration (SLICE-2), Test No. SFH-1	245
Figure D-10. Longitudinal Occupant Impact Velocity (SLICE-2), Test No. SFH-1	246
Figure D-11. Longitudinal Occupant Displacement (SLICE-2), Test No. SFH-1	247
Figure D-12. 10-ms Average Lateral Deceleration (SLICE-2), Test No. SFH-1	248
Figure D-13. Lateral Occupant Impact Velocity (SLICE-2), Test No. SFH-1	249
Figure D-14. Lateral Occupant Displacement (SLICE-2), Test No. SFH-1	250
Figure D-15. Vehicle Angular Displacements (SLICE-2), Test No. SFH-1	251
Figure D-16. Acceleration Severity Index (SLICE-2), Test No. SFH-1	252
Figure E-1. 10-ms Average Longitudinal Deceleration (SLICE-1), Test No. SFH-2	254
Figure E-2. Longitudinal Occupant Impact Velocity (SLICE-1), Test No. SFH-2	255
Figure E-3. Longitudinal Occupant Displacement (SLICE-1), Test No. SFH-2	256
Figure E-4. 10-ms Average Lateral Deceleration (SLICE-1), Test No. SFH-2	257
Figure E-5. Lateral Occupant Impact Velocity (SLICE-1), Test No. SFH-2	258
Figure E-6. Lateral Occupant Displacement (SLICE-1), Test No. SFH-2	259
Figure E-7. Vehicle Angular Displacements (SLICE-1), Test No. SFH-2	260
Figure E-8. Acceleration Severity Index (SLICE-1), Test No. SFH-2	261
Figure E-9. 10-ms Average Longitudinal Deceleration (SLICE-2), Test No. SFH-2	262
Figure E-10. Longitudinal Occupant Impact Velocity (SLICE-2), Test No. SFH-2	263
Figure E-11. Longitudinal Occupant Displacement (SLICE-2), Test No. SFH-2	264
Figure E-12. 10-ms Average Lateral Deceleration (SLICE-2), Test No. SFH-2	265
Figure E-13. Lateral Occupant Impact Velocity (SLICE-2), Test No. SFH-2	266
Figure E-14. Lateral Occupant Displacement (SLICE-2), Test No. SFH-2	267
Figure E-15. Vehicle Angular Displacements (SLICE-2), Test No. SFH-2	268
Figure E-16. Acceleration Severity Index (SLICE-2), Test No. SFH-2	269
Figure F-1. 10-ms Average Longitudinal Deceleration (SLICE-1), Test No. SFH-3	271
Figure F-2. Longitudinal Occupant Impact Velocity (SLICE-1), Test No. SFH-3	272
Figure F-3. Longitudinal Occupant Displacement (SLICE-1), Test No. SFH-3	273
Figure F-4. 10-ms Average Lateral Deceleration (SLICE-1), Test No. SFH-3	274
Figure F-5. Lateral Occupant Impact Velocity (SLICE-1), Test No. SFH-3	275
Figure F-6. Lateral Occupant Displacement (SLICE-1), Test No. SFH-3	276
Figure F-7. Vehicle Angular Displacements (SLICE-1), Test No. SFH-3	277
Figure F-8. Acceleration Severity Index (SLICE-1), Test No. SFH-3	278
Figure F-9. 10-ms Average Longitudinal Deceleration (SLICE-2), Test No. SFH-3	279
Figure F-10. Longitudinal Occupant Impact Velocity (SLICE-2), Test No. SFH-3	280
Figure F-11. Longitudinal Occupant Displacement (SLICE-2), Test No. SFH-3	281
Figure F-12. 10-ms Average Lateral Deceleration (SLICE-2), Test No. SFH-3	282
Figure F-13. Lateral Occupant Impact Velocity (SLICE-2), Test No. SFH-3	283
Figure F-14. Lateral Occupant Displacement (SLICE-2), Test No. SFH-3	284
Figure F-15. Vehicle Angular Displacements (SLICE-2), Test No. SFH-3	285
Figure F-16. Acceleration Severity Index (SLICE-2), Test No. SFH-3	286
Figure F-17. 10-ms Average Longitudinal Deceleration (DTS), Test No. SFH-3	287

Figure F-18. Longitudinal Occupant Impact Velocity (DTS), Test No. SFH-3288
Figure F-19. Longitudinal Occupant Displacement (DTS), Test No. SFH-3289
Figure F-20. 10-ms Average Lateral Deceleration (DTS), Test No. SFH-3.....290
Figure F-21. Lateral Occupant Impact Velocity (DTS), Test No. SFH-3291
Figure F-22. Lateral Occupant Displacement (DTS), Test No. SFH-3292
Figure F-23. Vehicle Angular Displacements (DTS), Test No. SFH-3.....293
Figure F-24. Acceleration Severity Index (DTS), Test No. SFH-3294

LIST OF TABLES

Table 1. MASH TL-4 Crash Test Conditions for Longitudinal Barriers [4]	34
Table 2. MASH Evaluation Criteria for Longitudinal Barrier.....	36
Table 3. Weather Conditions, Test No. SFH-1	59
Table 4. Sequential Description of Impact Events, Test No. SFH-1	60
Table 5. Barrier Deflections at Maximum Deflection Times, Test No. SFH-1	62
Table 6. Maximum Occupant Compartment Deformations by Location, Test No. SFH-1	62
Table 7. Summary of OIV, ORA, THIV, PHD, and ASI Values, Test No. SFH-1	65
Table 8. Test and Force Comparisons, 2270P Vehicle	80
Table 9. Weather Conditions, Test No. SFH-2	86
Table 10. Sequential Description of Impact Events, Test No. SFH-2	87
Table 11. Barrier Deflections at Maximum Deflection Times, Test No. SFH-2.....	89
Table 12. Maximum Occupant Compartment Deformations by Location, Test No. SFH-2.....	90
Table 13. Summary of OIV, ORA, THIV, PHD, and ASI Values, Test No. SFH-2.....	91
Table 14. Test and Force Comparisons, 1100C Vehicle	108
Table 15. Weather Conditions, Test No. SFH-3	140
Table 16. Sequential Description of Impact Events, Test No. SFH-3	141
Table 17. Barrier Deflections at Maximum Deflection Times, Test No. SFH-3.....	143
Table 18. Maximum Occupant Compartment Deformations by Location, Test No. SFH-3.....	145
Table 19. Summary of OIV, ORA, and ASI Values, Test No. SFH-3	146
Table 20. Summary of Safety Performance Evaluation Results.....	174
Table A-1. Bill of Materials, Test Nos. SFH-1 and SFH-2	179
Table A-2. Bill of Materials, Test Nos. SFH-3.....	181

1 INTRODUCTION

1.1 Background

Passenger vehicle impacts into rigid concrete barriers can result in severe and fatal injuries to the occupants due to the non-forgiving nature of the barrier. However, concrete barriers are successful at containing and redirecting large truck impacts. Therefore, a forgiving, restorable, energy-absorbing, longitudinal barrier concept was developed by Schmidt, et al. [1-3] that would reduce the lateral acceleration imparted to passenger vehicle occupants during impacts, while still redirecting large truck impacts.

There were several design criteria for the barrier. First, the barrier was to satisfy the Association of American State Highway and Transportation Officials (AASHTO) *Manual for Assessing Safety Hardware* (MASH) Test Level 4 (TL-4) crash testing criteria [4]. Also, a 30 percent decrease in the lateral acceleration on passenger vehicles was desired with impacts into the new barrier, compared to similar impacts with rigid concrete barriers. The barrier width needed to be less than or equal to 36 in. (914 mm) to accommodate current urban median footprint widths. The initial fabrication and installation costs needed to be competitive with current concrete barriers, and maintenance costs for the new barrier system were projected to be virtually zero under normal impact conditions. The system should be restorable and reusable, with no damage occurring during passenger vehicle impacts. A minimal amount of damage is permissible with single-unit truck impact events.

The selected barrier design incorporated rubber posts with a concrete beam placed on top of the posts, as shown in Figure 1 [1-3]. Several components of this design make it a unique restorable and reusable, energy-absorbing, longitudinal TL-4 roadside and median barrier. The rubber posts were designed to deform and absorb energy in shear when impacted and fully restore after impact events. The maximum lateral acceleration during pickup truck events was

estimated, through analytical calculations and finite element analysis, to be reduced by 30 percent with 7 to 10 in. (178 to 254 mm) of deflection as compared to similar impacts with rigid barriers [3]. A combination concrete and steel tube rail was optimized to minimize weight, have sufficient strength capacity, and maintain a height to contain and redirect the TL-4 single-unit truck [3]. The bottom height of the concrete beam was selected to prevent passenger vehicles from underriding the barrier and impacting the posts [3]. Although initial static component testing demonstrated that the rubber posts could support the beam weight, variations in the fabricated components and installation site led to the addition of steel support skids to increase the system stability [2-3]. Therefore, the rubber posts and steel skids both support the vertical weight of the beam and stabilize the system. The skids also appeared to control rotation of the barriers during computer simulation impact events, which helped the barrier restore [3].

To achieve the desired acceleration reductions compared to rigid-barrier impacts, the impact force needed to be distributed to multiple rubber posts. It was also desired that the system would be made of prefabricated segments to make installation easier. Therefore, a new joint was developed to add continuity to precast concrete beam segments and allow the impact force to be distributed to the greatest number of posts. The joint between concrete beams consisted of two steel angles that bolt through the front and back faces of the concrete beams. The barrier was designed for a ½-in. (13-mm) gap between adjacent segments, and the new joint allowed for ±¼-in. (6-mm) of tolerance. The tolerance on the gap between adjacent beams allows for overall construction tolerances, as well as some adjustability when installing the system on roadways with horizontal and vertical curvature. Development and further details of the joint can be found in Schmidt, et al. [3]. All system components work together to contain and redirect vehicles, absorb energy, restore, and be reusable to sustain multiple impacts.



Figure 1. View of Initial Concept with Rubber Posts and Metal Skids [3]

1.2 Objective

The objective was to evaluate the safety performance of a new restorable and reusable, energy-absorbing, longitudinal barrier system according to the MASH TL-4 requirements. Additionally, the test results were to be compared to similar TL-4 impacts into rigid barriers.

1.3 Scope

The research objective was accomplished by completing a series of tasks. First, a 240-ft (73-m) long barrier was constructed, designated the RESTORE barrier. Three full-scale vehicle crash tests were conducted on the same barrier to evaluate its performance. The first test was a MASH test designation no. 4-11 and utilized a ½-ton Quad Cab pickup truck, weighing approximately 5,000 lb (2,268 kg), impacting at a targeted speed and angle of 62 mph (100 km/h) and 25 degrees, respectively. The second test was a MASH test designation no. 4-10 and

utilized a small car, weighing approximately 2,425 lb (1,100 kg), impacting the barrier at a targeted speed and angle of 62 mph (100 km/h) and 25 degrees, respectively. The third test was a MASH test designation no. 4-12 and utilized a single-unit truck, weighing approximately 22,000 lb (10,000 kg), impacting the barrier at a targeted speed and angle of 56 mph (90 km/h) and 15 degrees, respectively. Finally, the test results were analyzed, evaluated, and documented. Conclusions and recommendations were then made that pertain to the safety performance of the RESTORE barrier.

2 DESIGN DETAILS TEST NOS. SFH-1 AND SFH-2

The barrier system test installation consisted of precast concrete beams, energy-absorbing rubber posts, wedge-shaped steel joints, skids, and an upper tube assembly, as shown in Figures 2 through 25. The total length of the median barrier system was 239 ft - 11½ in. (73.1 m). Photographs of the test installation are shown in Figures 26 through 28. Material specifications, mill certifications, and certificates of conformity for the system materials are shown in Appendix A.

The system consisted of twelve 19-ft 11½-in. (6.1-m) long x 18½-in. (470-mm) tall x 21½-in. (546-mm) wide concrete beams. The concrete beam was designed with a light-weight concrete mix with a minimum 28-day compressive strength of 5,000 psi (34 MPa). The concrete beam that was used during testing had an average 28-day compressive strength of 6,652 psi (46 MPa), as shown in Appendix A. The density of the concrete was 110 pcf (1,762 kg/m³). The concrete beams had three 6⁵/₈-in. (168-mm) diameter vertical holes spaced evenly between each post, as shown in Figure 7. The ends of each concrete beam were chamfered at a 45 degree angle, and a pentagon-shaped vertical hole was cast into the beam near each end, as shown in Figure 8. The geometry was such that eight 1-in. (25-mm) diameter bolts could be placed at 45 degree angles through the beams and wedge-shaped steel joints, designated the Adjustable Continuity Joint (ACJ), would connect the concrete beams, as shown in Figures 4 and 20. A 239½-in. (6,083-mm) long, 8-in. x 4-in. x ¼-in. (203-mm x 102-mm x 6-mm) steel tube was mounted on top of the concrete segments using 4-in. x 4-in. (102-mm x 102-mm) posts and four ¾-in. (19-mm) diameter threaded rods running through the concrete beam to the posts underneath. Adjacent steel tubes were spliced with a bent plate and two bolts.

Each concrete beam was supported by four rubber posts and two steel skids. The posts were spaced at 60 in. (1,524 mm) on-center, while the skids were spaced at 120 in. (3,048 mm)

on-center. The posts were made of ASTM D2000 rubber. Each post was anchored to the tarmac with four epoxy anchors with an 8-in. (203-mm) embedment. The steel skid was a 6½-in. (165-mm) outer diameter pipe that was ⅜-in. (10-mm) thick and was welded to a 14-in. (356-mm) long base plate with the ends flared upwards. A 12-in. (305-mm) x 12-in. (305-mm) top steel plate was also welded 11 in. (279 mm) above the groundline with gussets. The upper portion of the skid pipes was inserted into the 6⅝ in. (168 mm) diameter holes in each concrete beam. A ½-in. (13-mm) elastomer pad was inserted between the top steel plate and the bottom of the concrete beam.

The installation for test no. SFH-2 was the same as the system used for test no. SFH-1, except the impact point was moved downstream, in order to distinguish damage from the previous test, as shown in Figure 25.

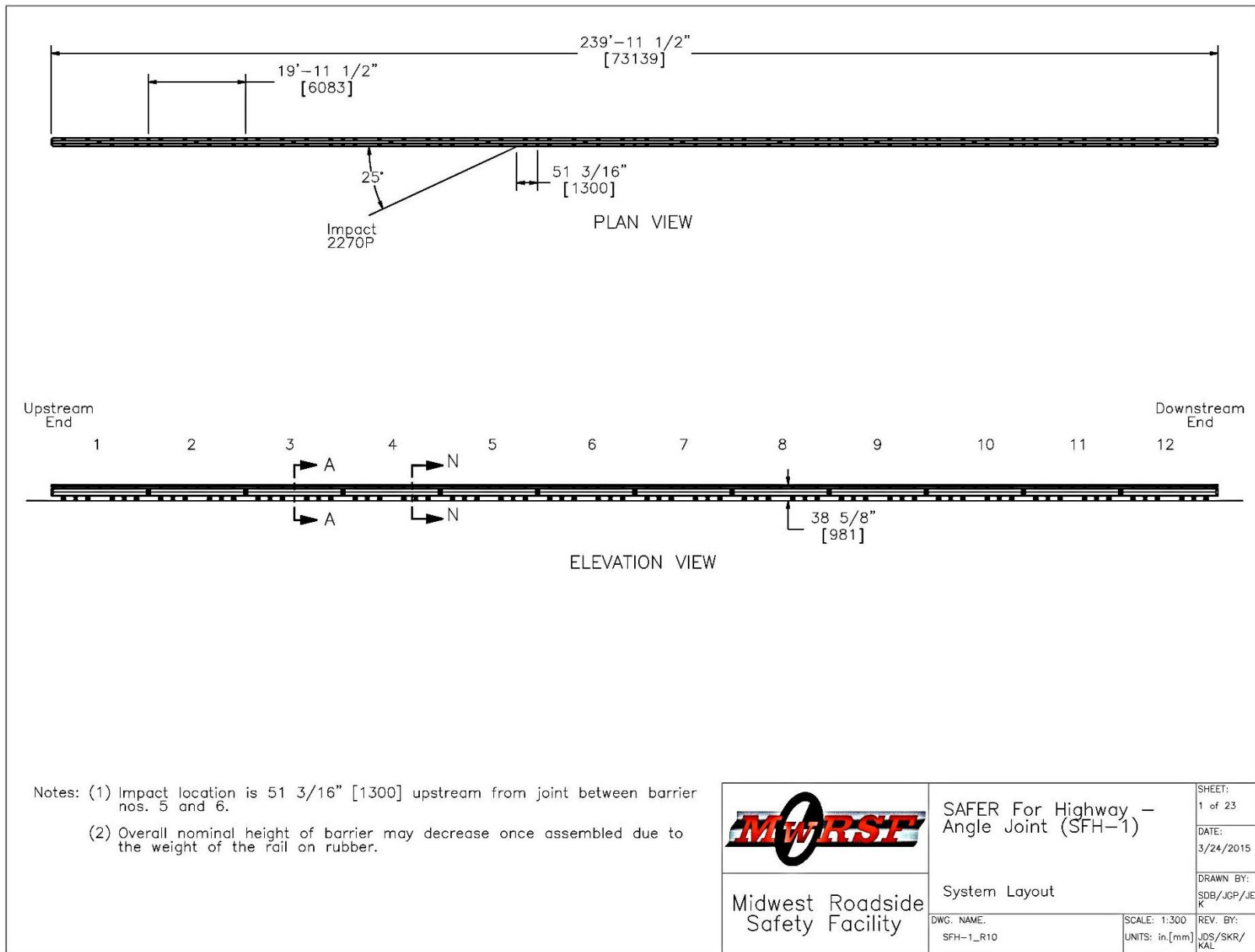

Figure 2. Test Installation Layout, Test No. SFH-1

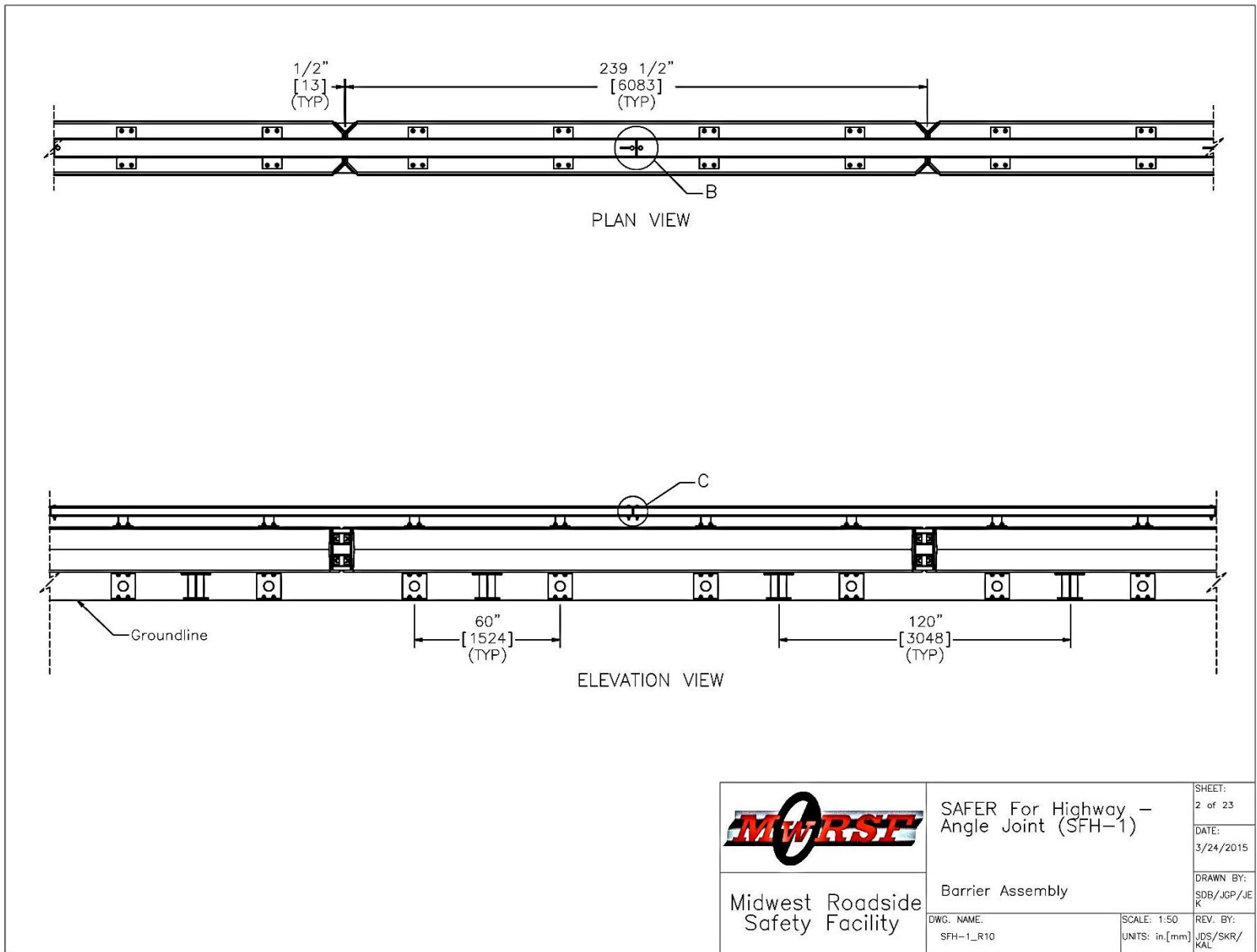

Figure 3. Barrier Assembly, Test Nos. SFH-1 and SFH-2

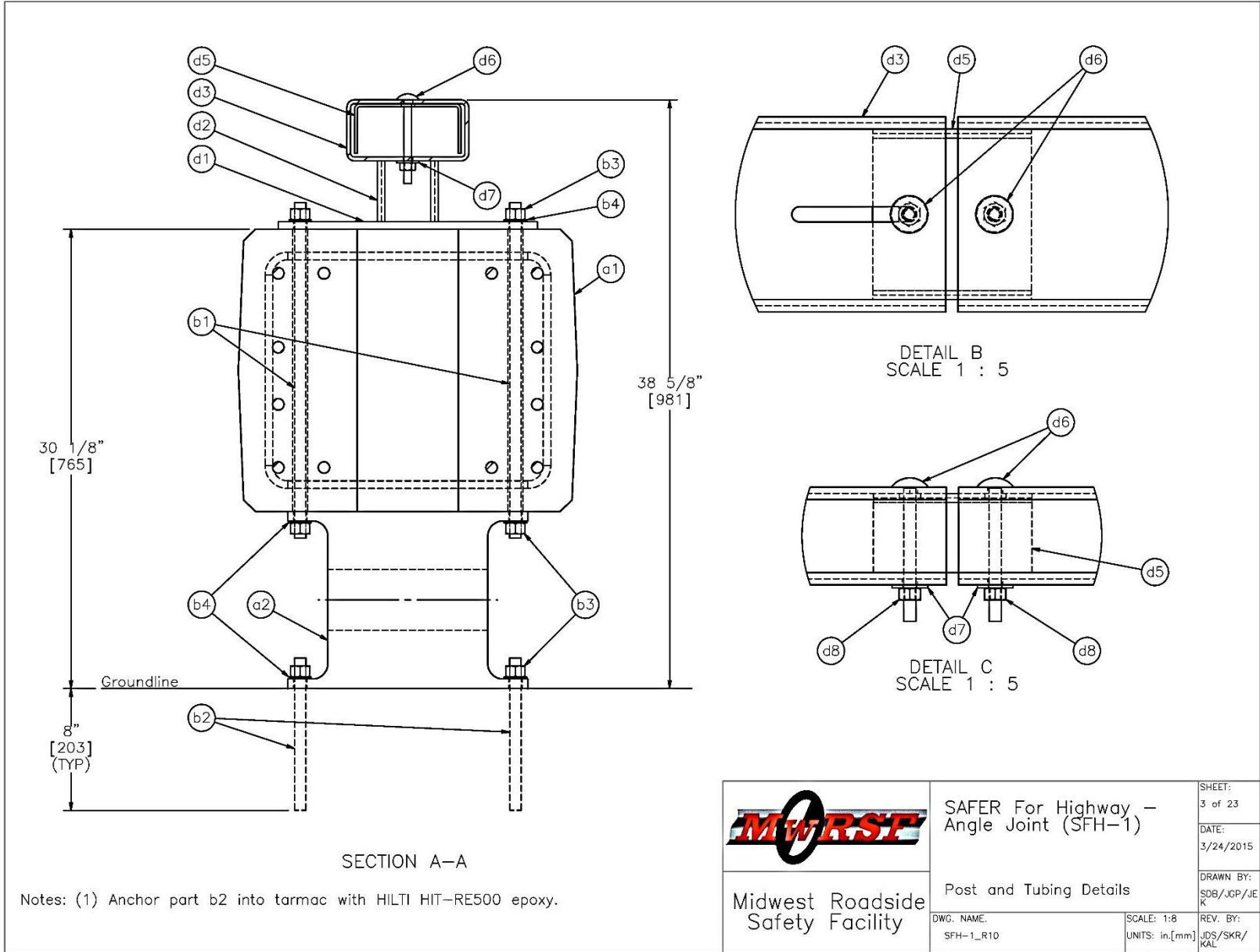

Figure 4. Post and Tubing Details, Test Nos. SFH-1 and SFH-2

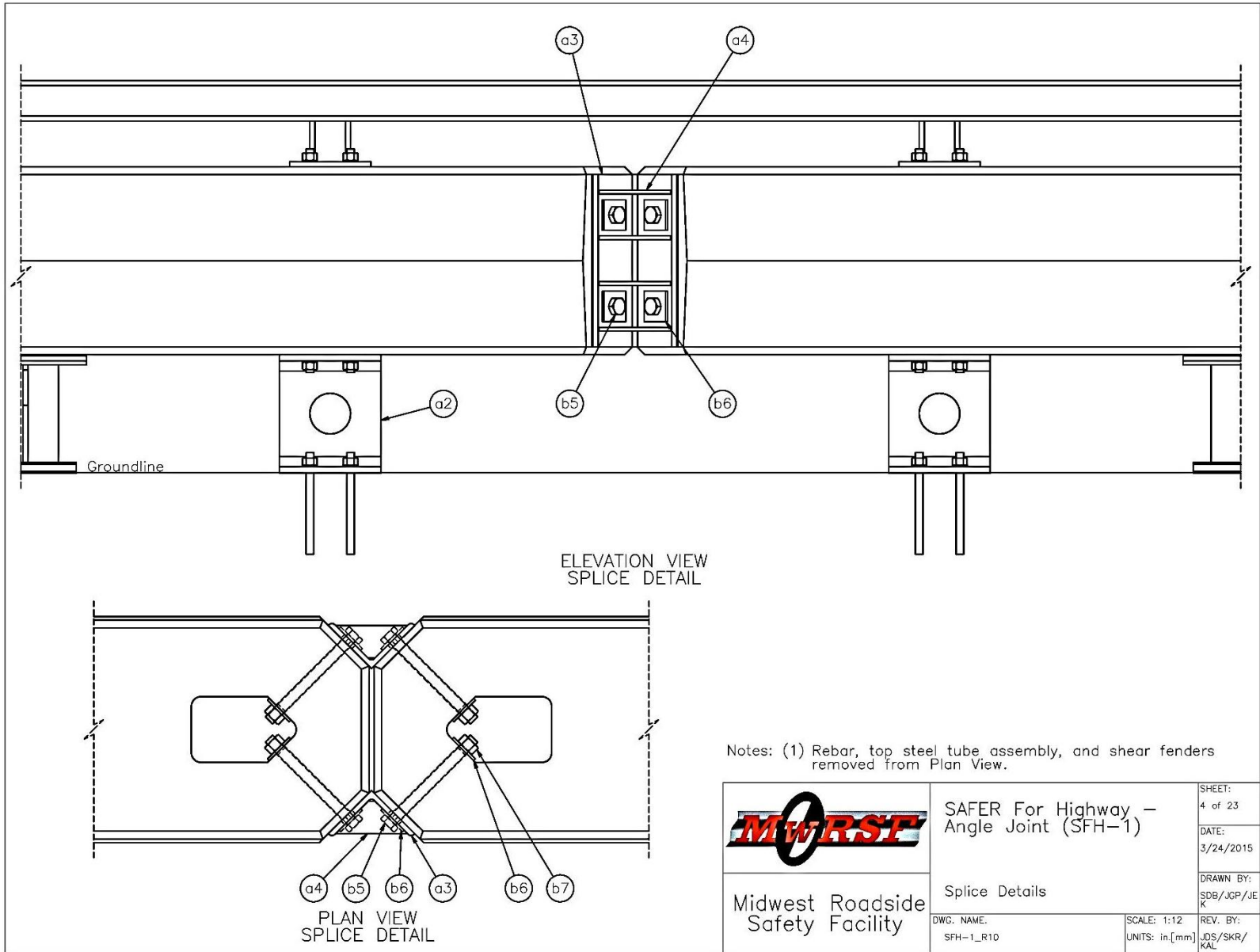

Figure 5. Splice Details, Test Nos. SFH-1 and SFH-2

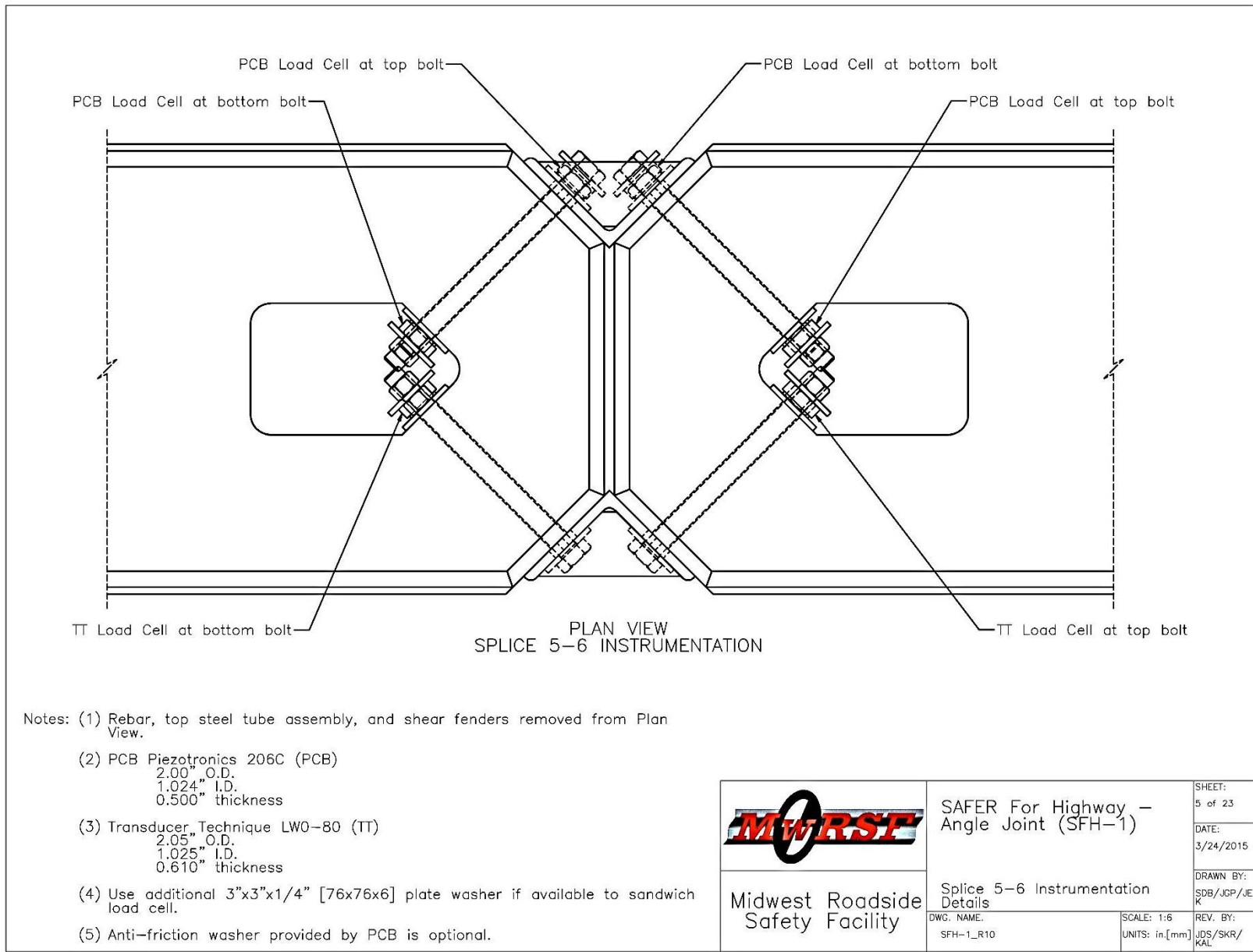

Figure 6. Splice 5-6 Instrumentation Details, Test No. SFH-1

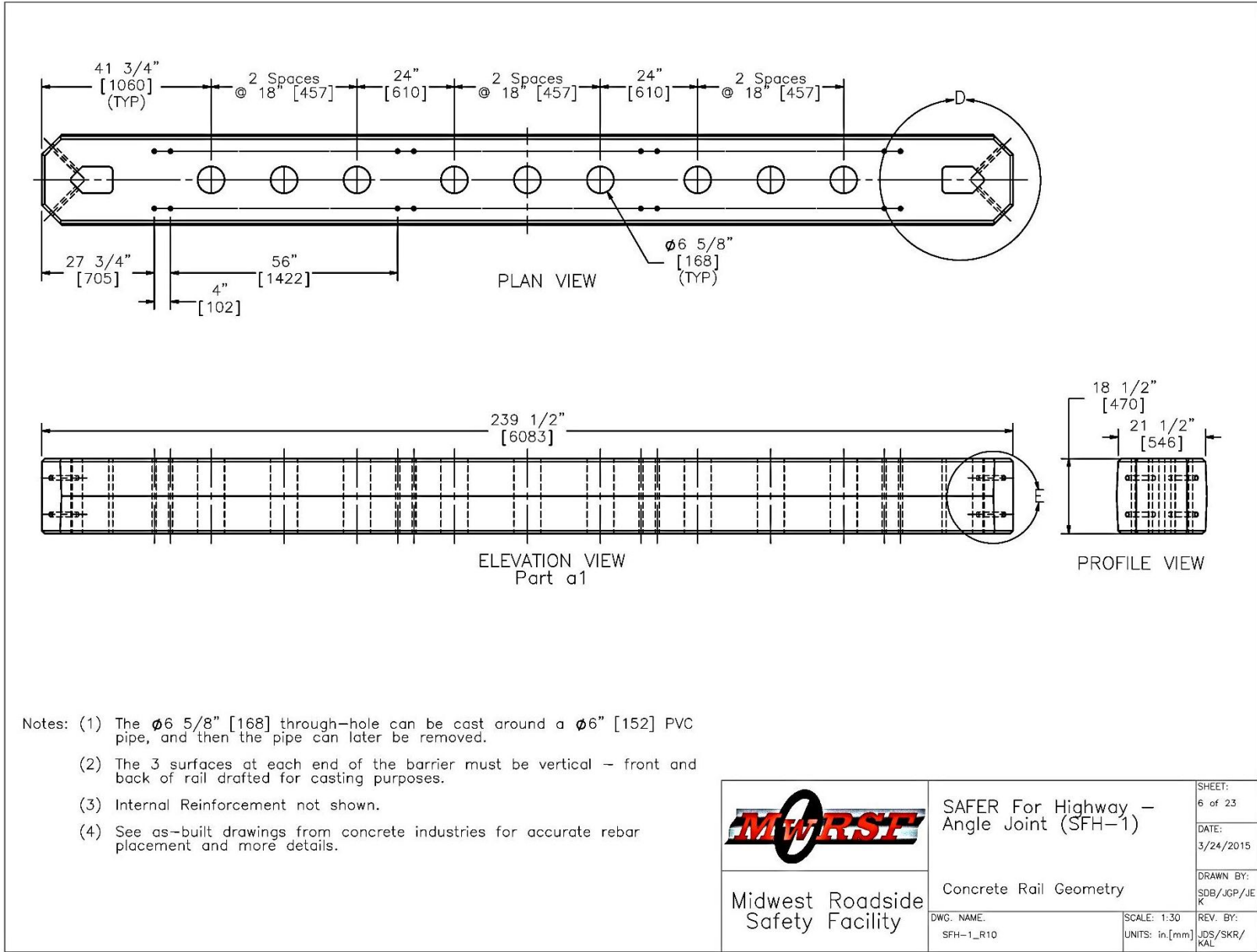

Figure 7. Concrete Beam Geometry, Test Nos. SFH-1 and SFH-2

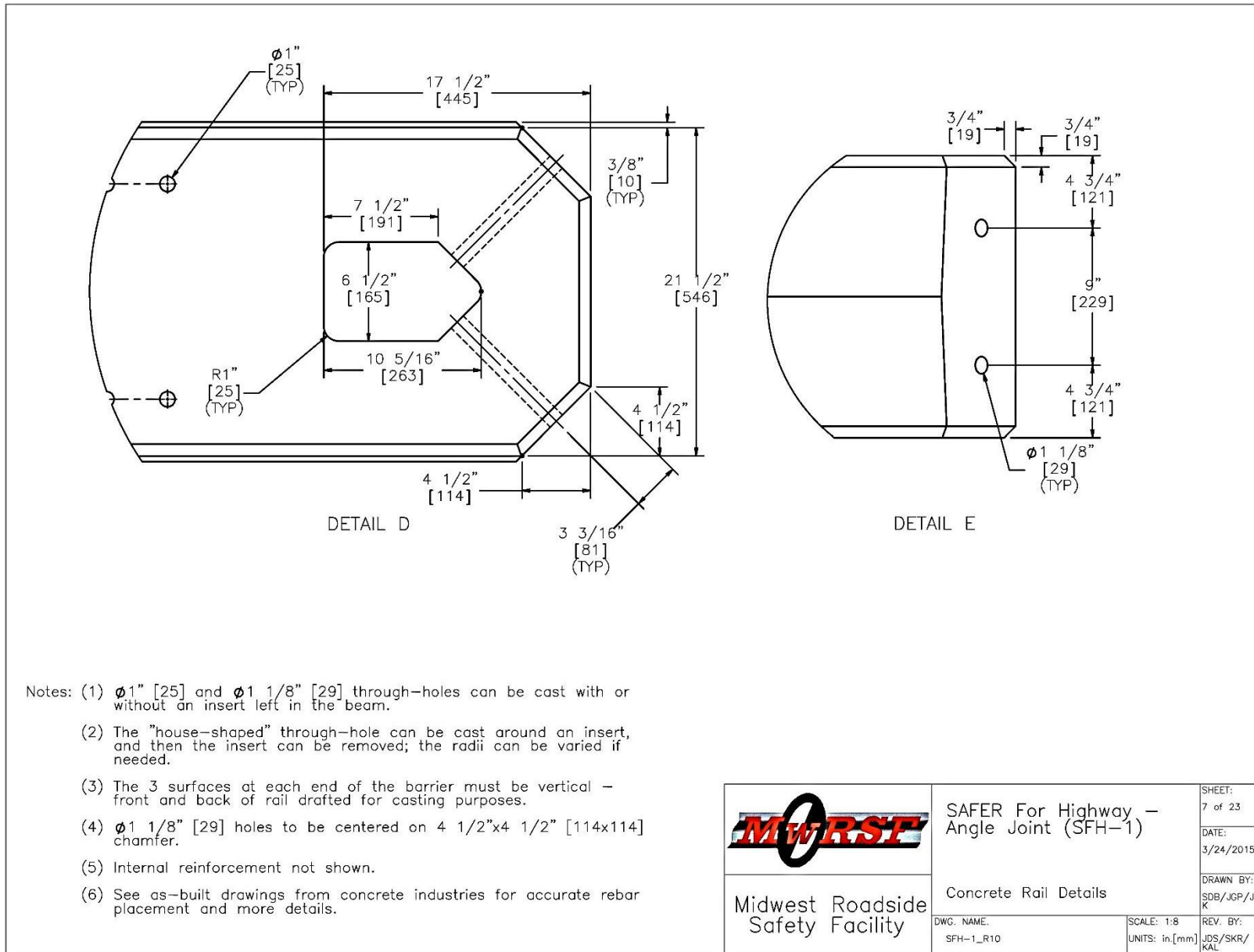
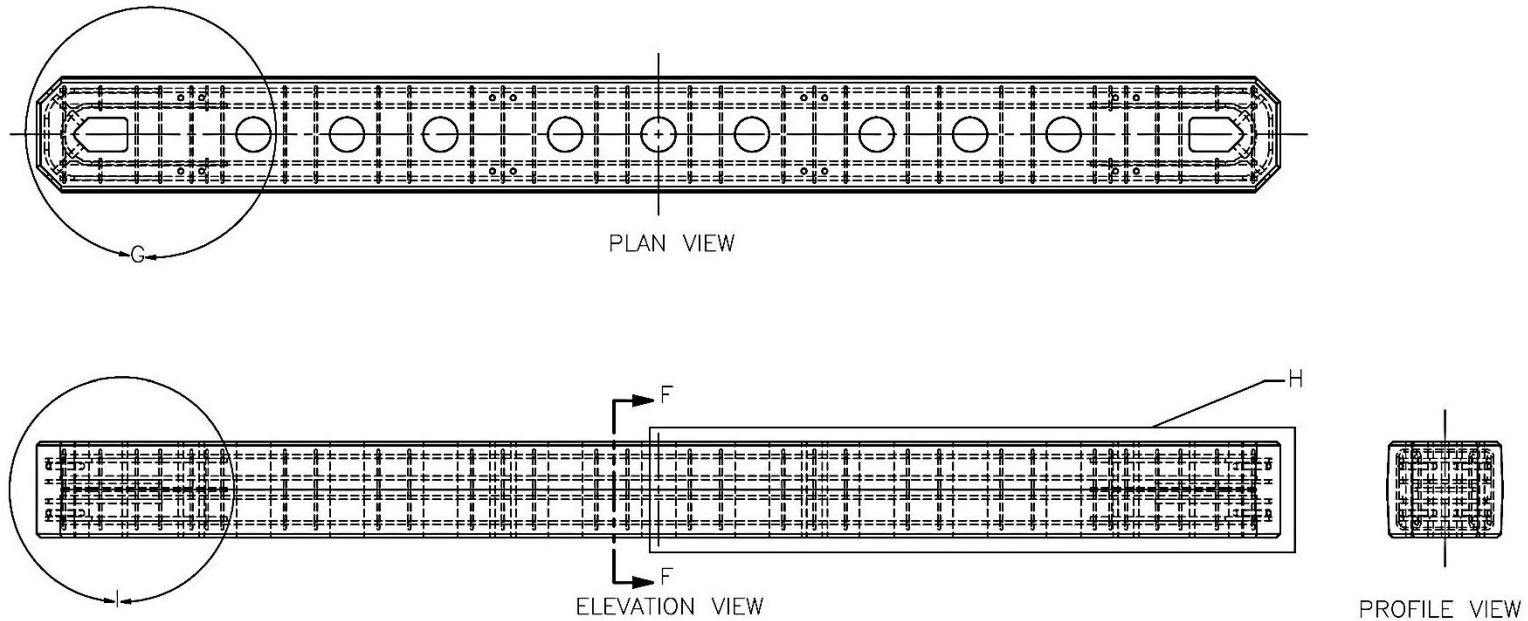

Figure 8. Concrete Beam Details, Test Nos. SFH-1 and SFH-2



Notes: (1) Two single flared coil loop inserts (not shown) were added to each barrier segment.

 Midwest Roadside Safety Facility	SAFER For Highway – Angle Joint (SFH-1)	SHEET: 8 of 23
	Concrete Rail and Rebar Assembly	DATE: 3/24/2015
DWG. NAME: SFH-1_R10	SCALE: 1:30 UNITS: in,[mm]	DRAWN BY: SDB/JCP/JEK REV. BY: JDS/SKR/KAL

Figure 9. Concrete Beam and Rebar Assembly, Test Nos. SFH-1 and SFH-2

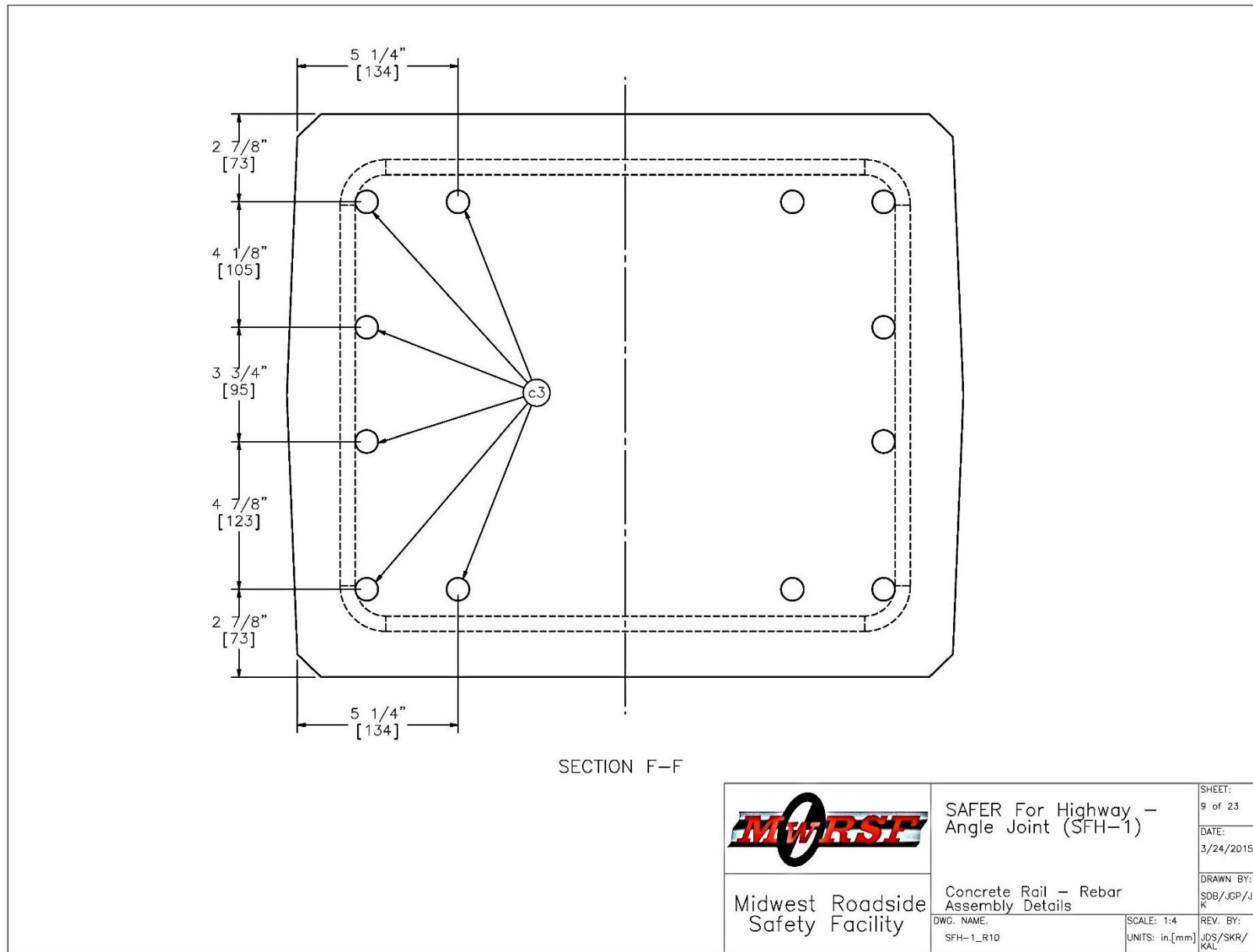

Figure 10. Concrete Beam, Rebar Assembly Details, Test Nos. SFH-1 and SFH-2

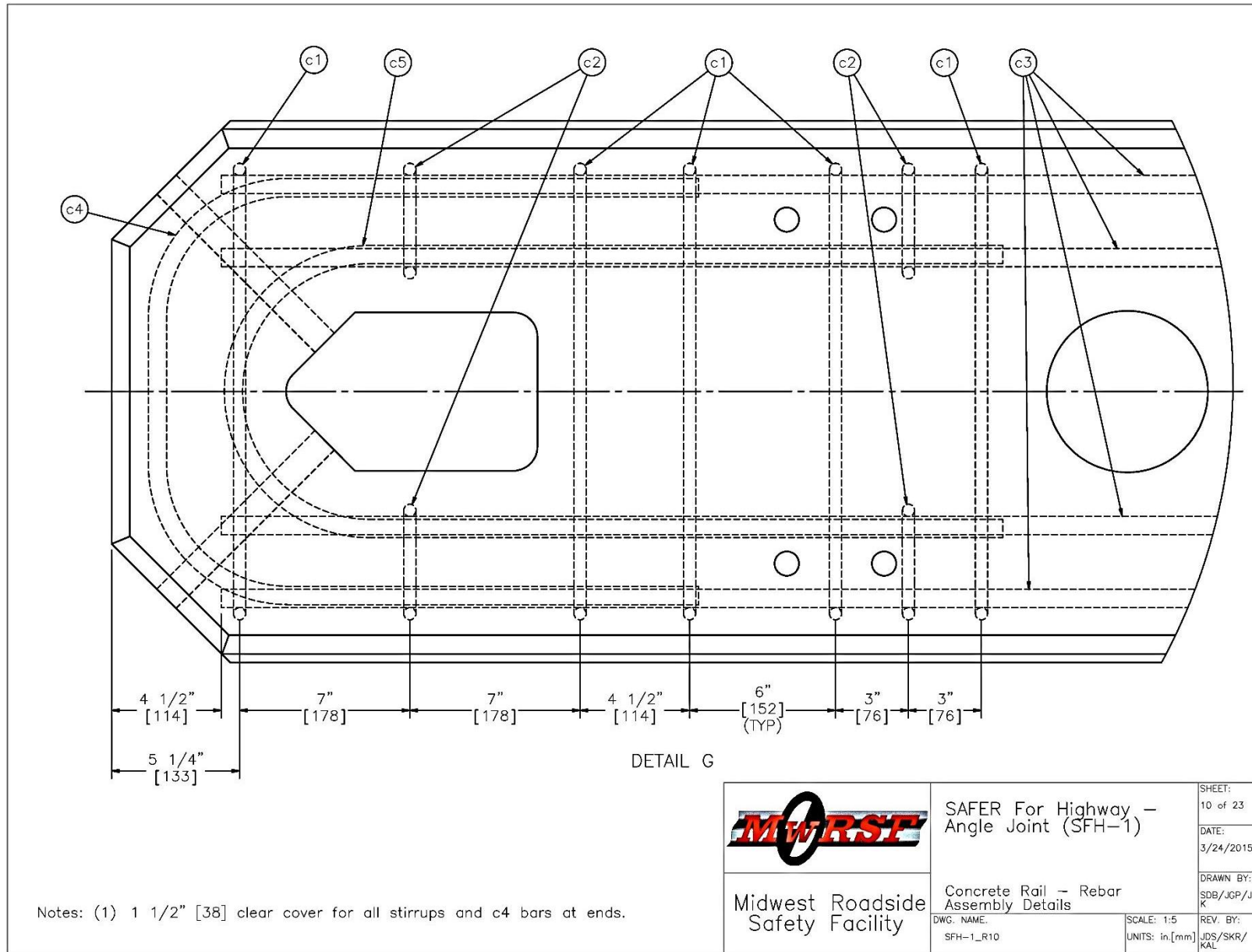

Figure 11. Concrete Beam, Rebar Assembly Details, Test Nos. SFH-1 and SFH-2

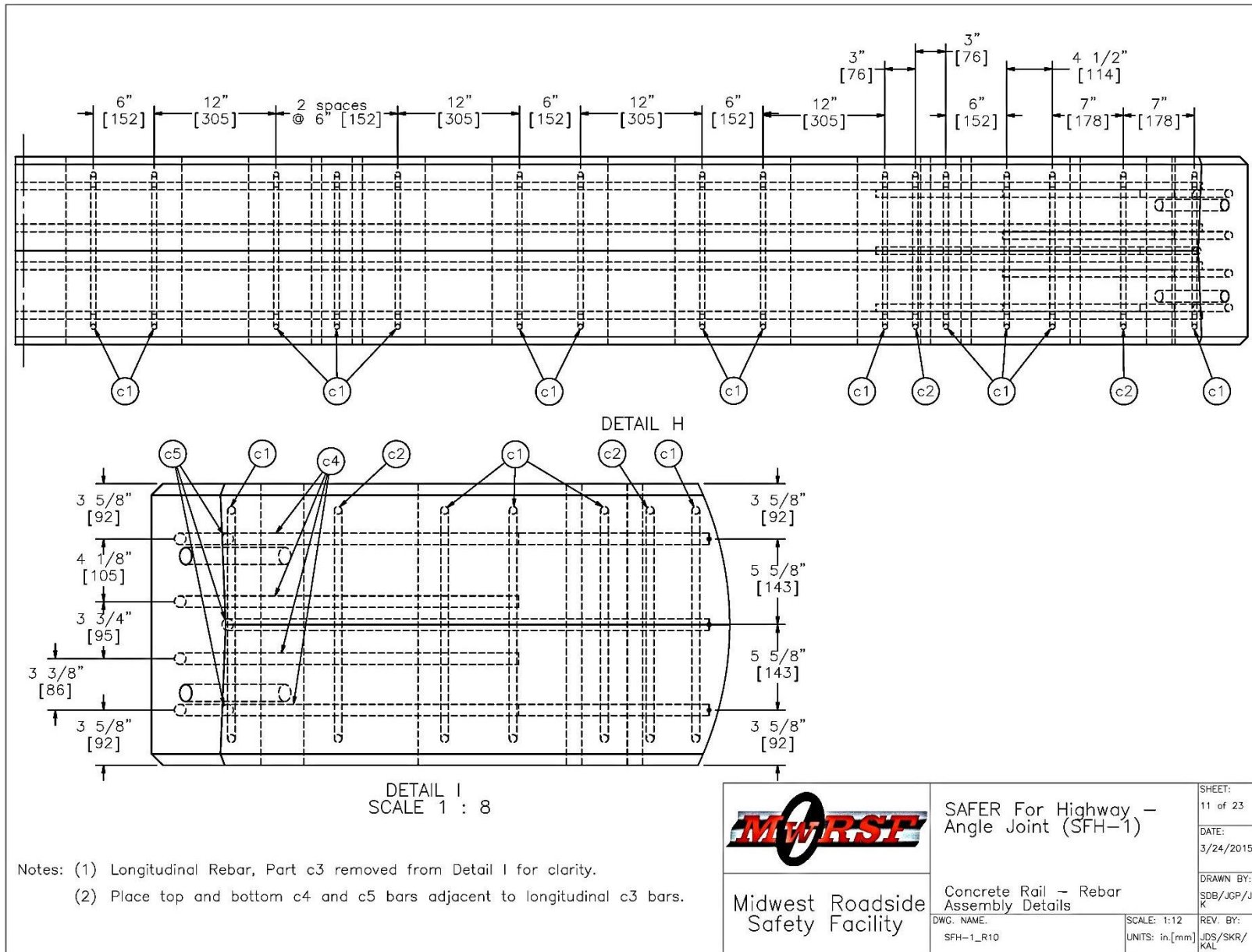

Figure 12. Concrete Beam, Rebar Assembly Details, Test Nos. SFH-1 and SFH-2

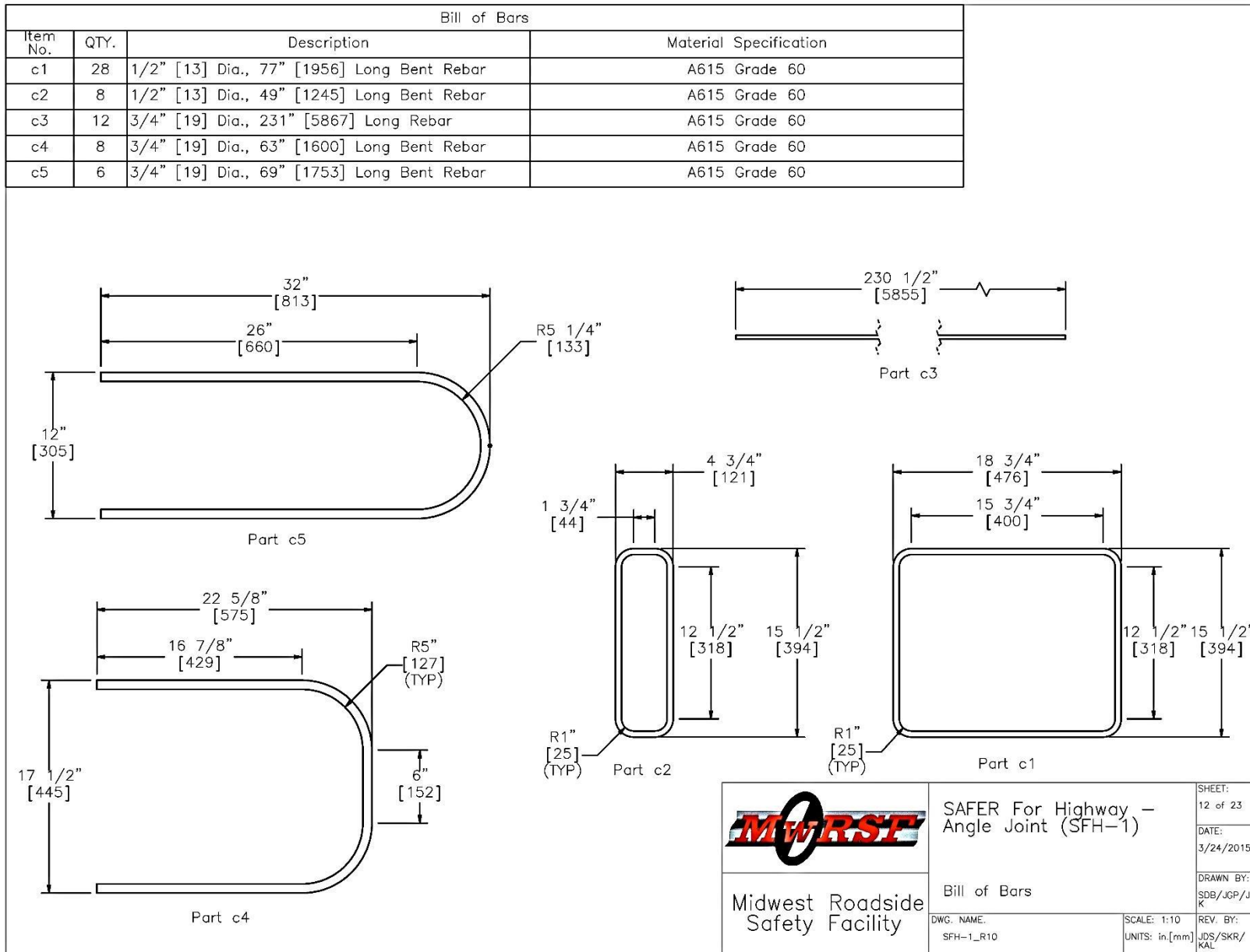

Figure 13. Bill of Bars, Test Nos. SFH-1 and SFH-2

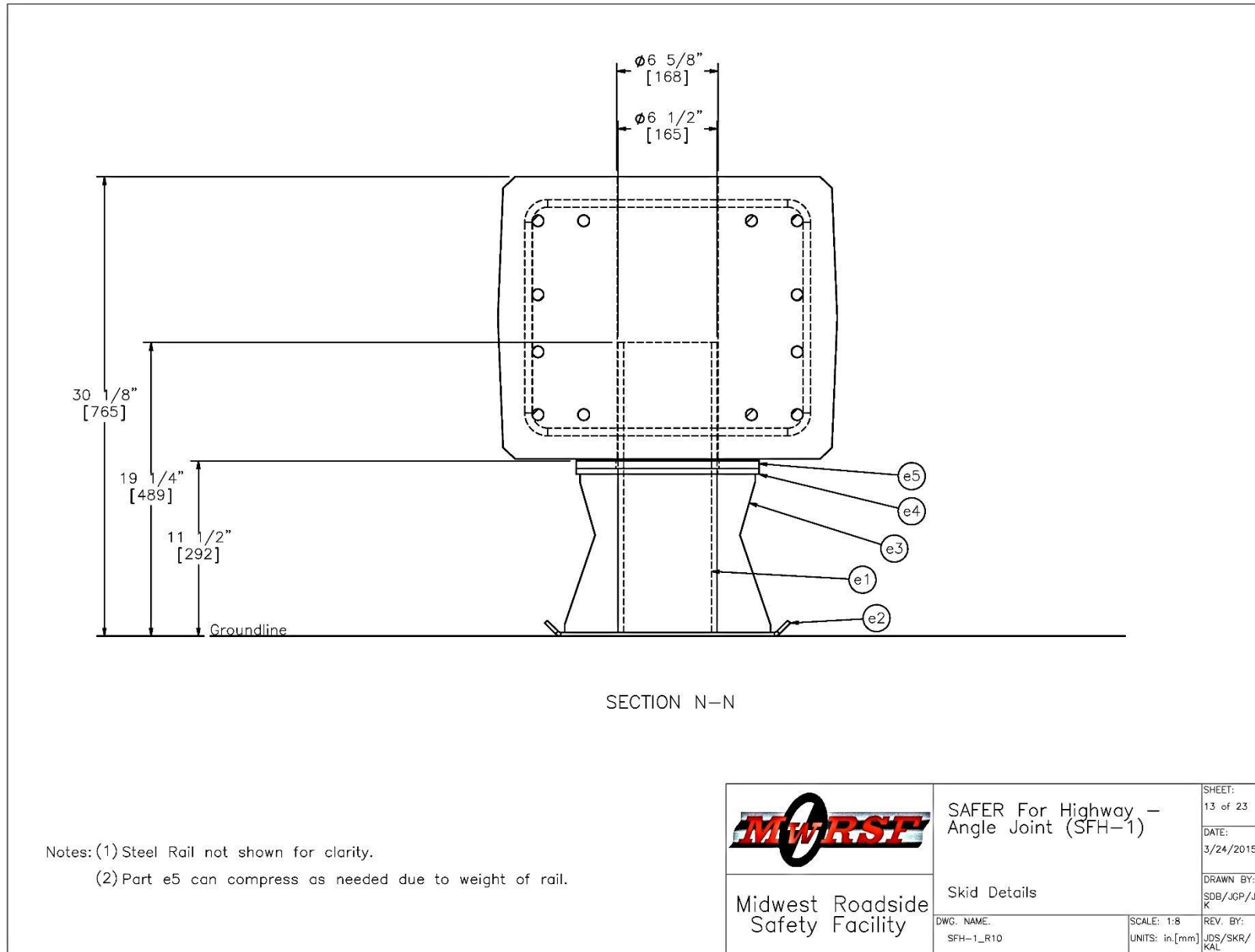

Figure 14. Skid Details, Test Nos. SFH-1 and SFH-2

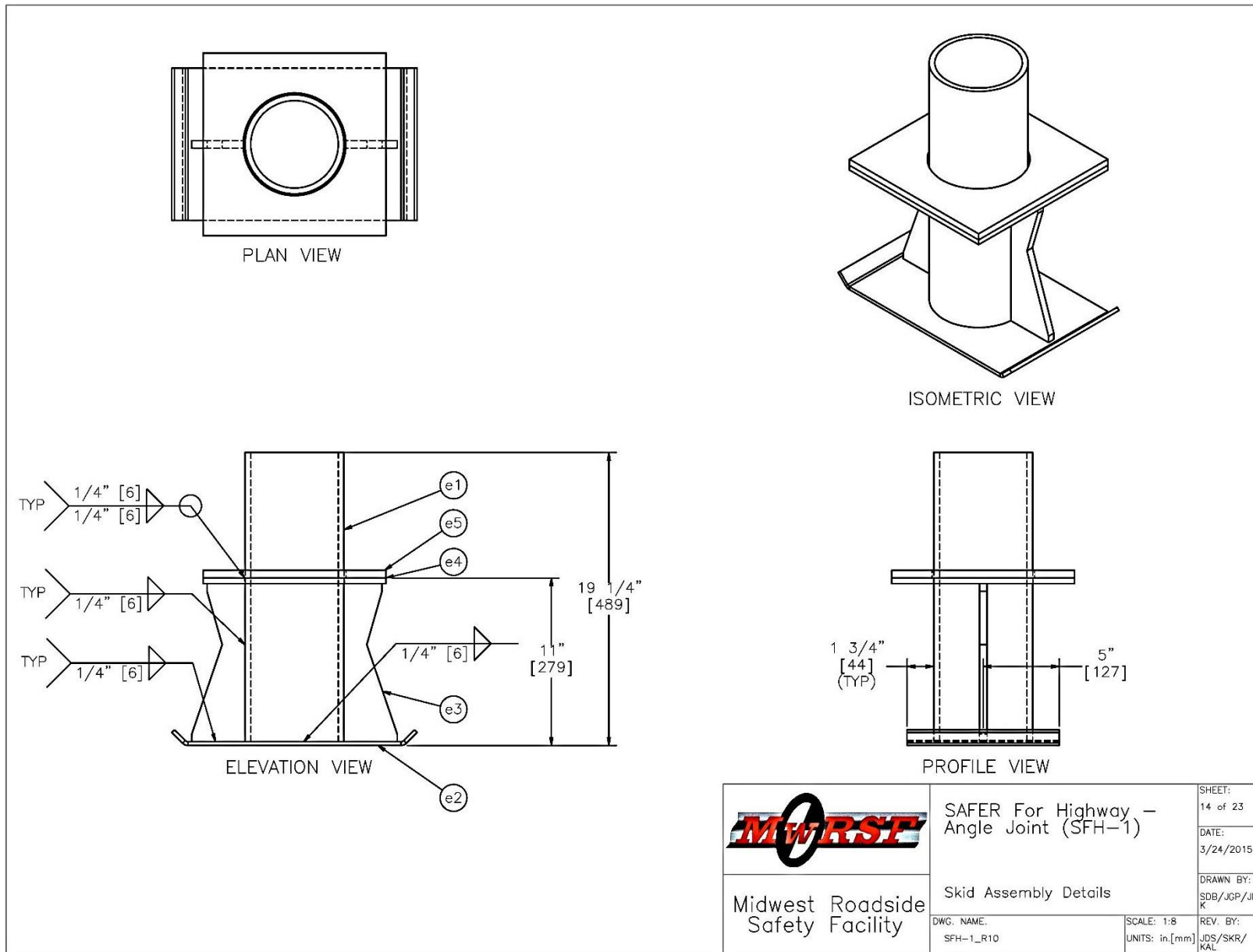

Figure 15. Skid Assembly Details, Test Nos. SFH-1 and SFH-2

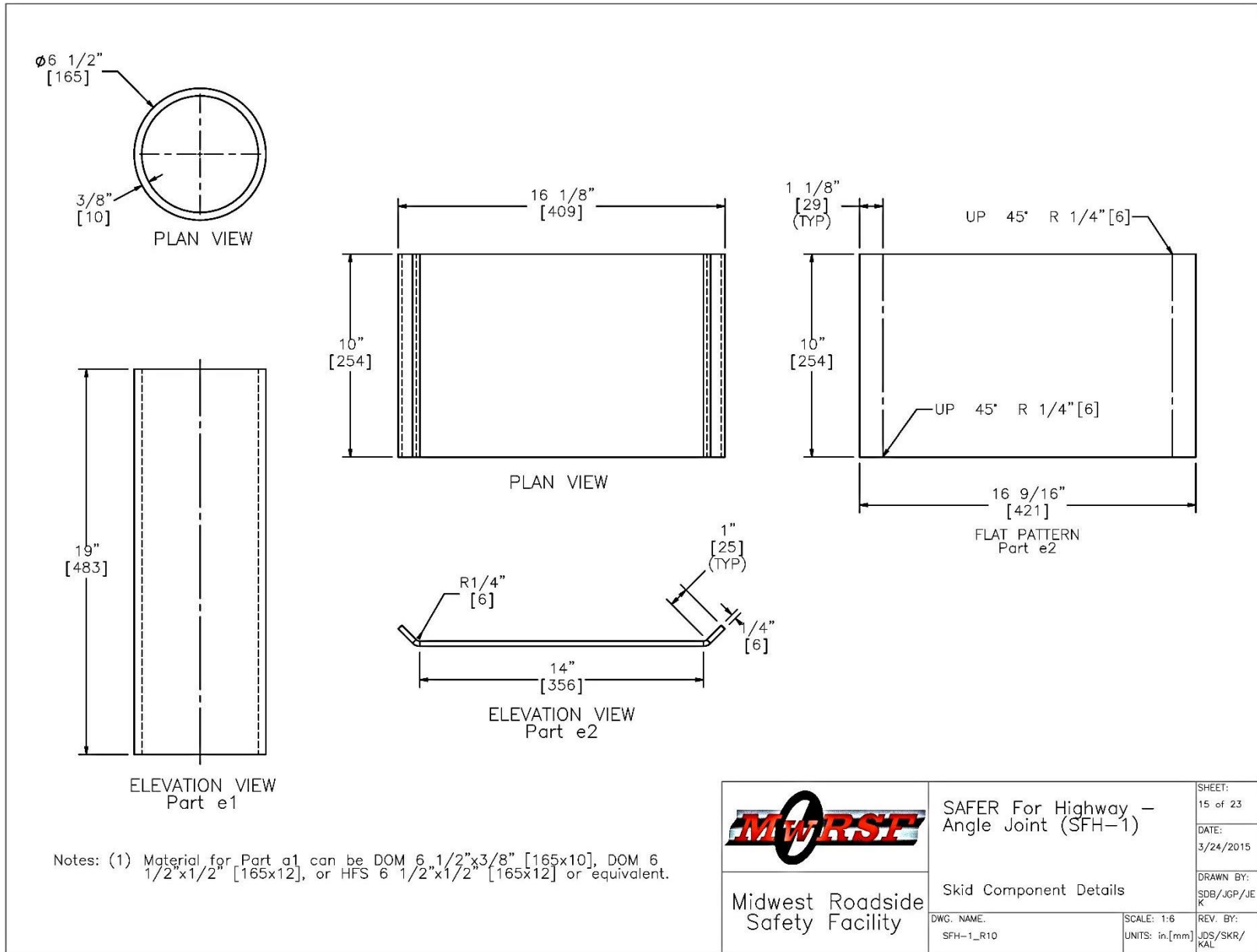

Figure 16. Skid Component Details, Test Nos. SFH-1 and SFH-2

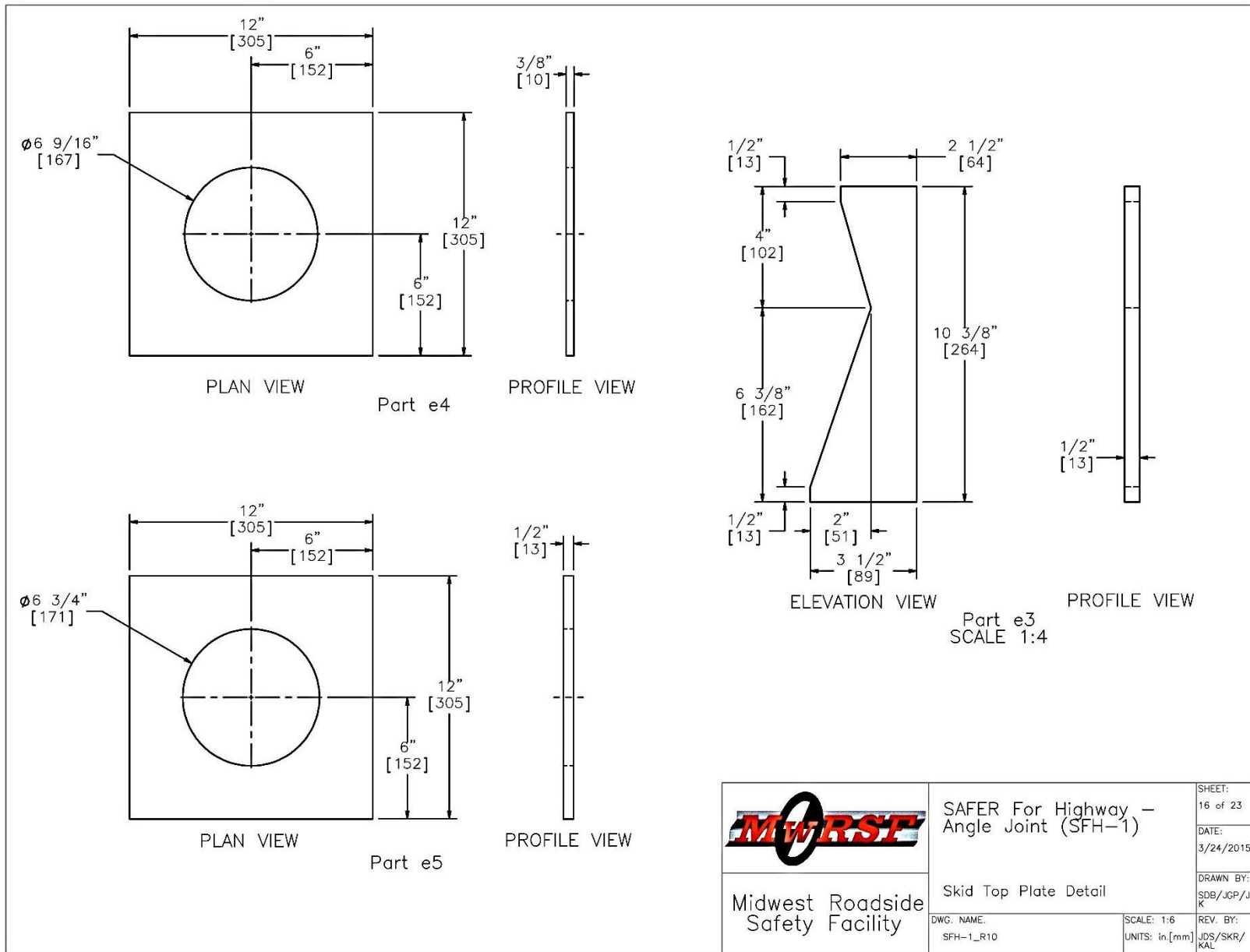

Figure 17. Skid Top Plate Detail, Test Nos. SFH-1 and SFH-2

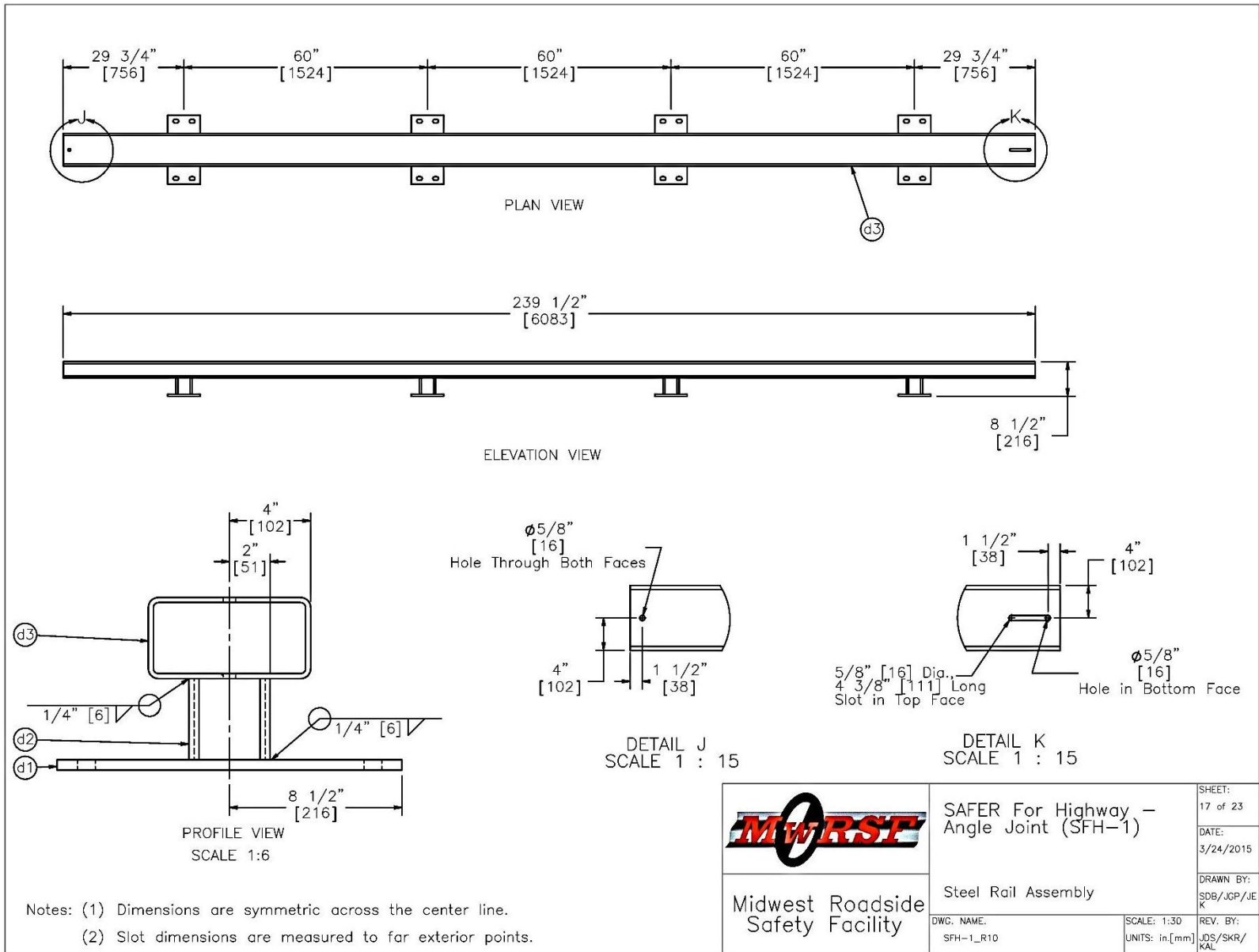

Figure 18. Upper Tube Assembly, Test Nos. SFH-1 and SFH-2

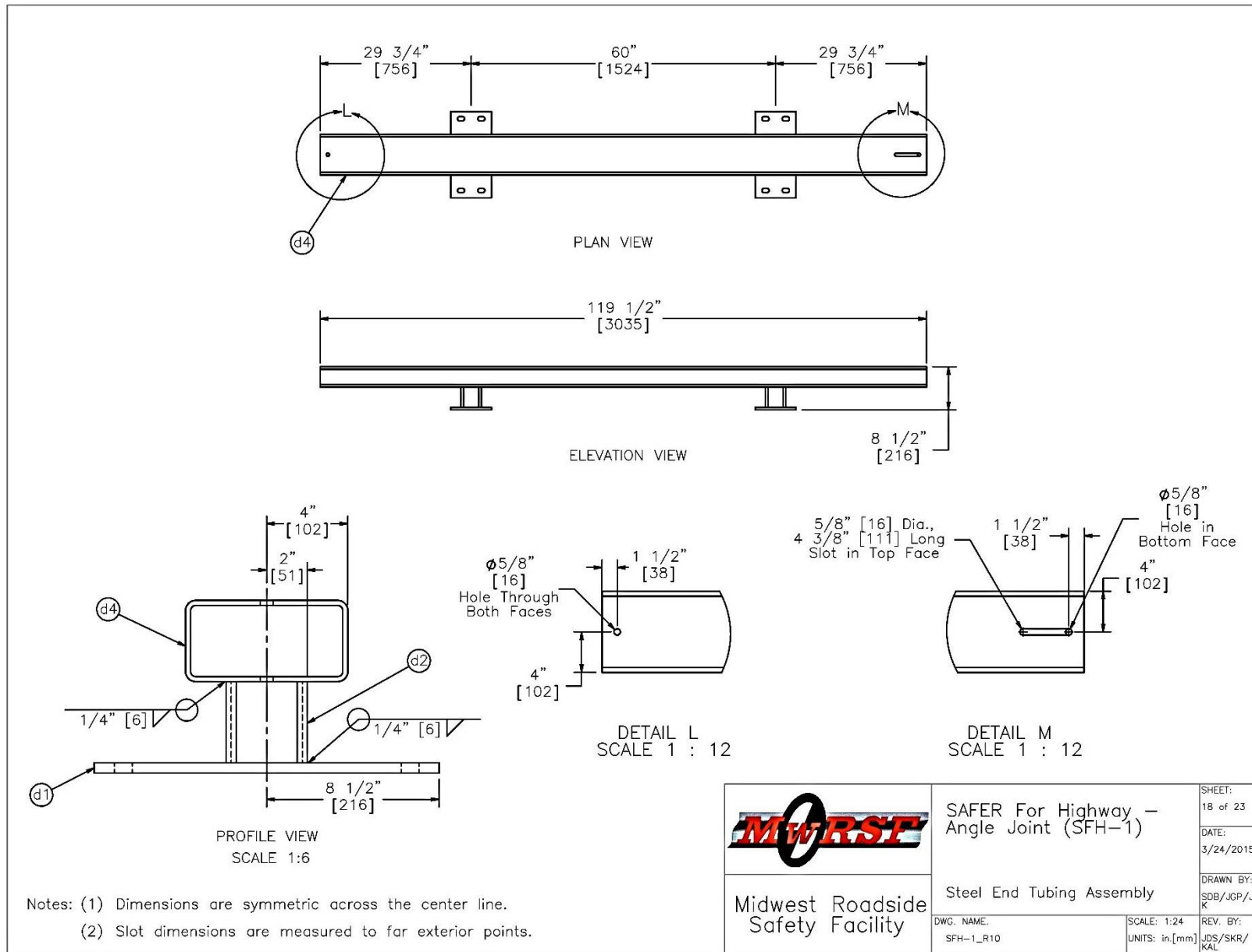

Figure 19. Steel End Tubing Assembly, Test Nos. SFH-1 and SFH-2

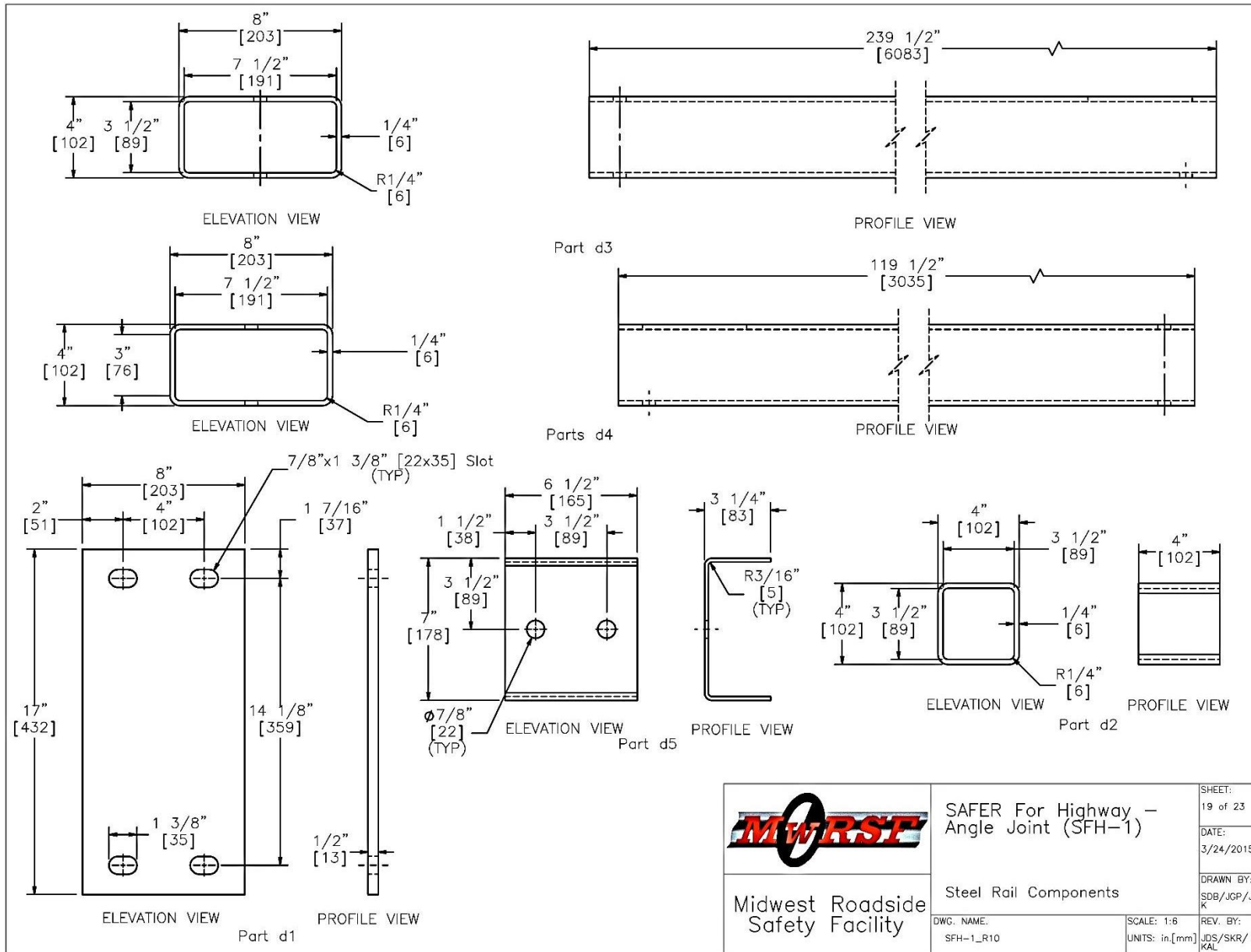

Figure 20. Steel Tubing Components, Test Nos. SFH-1 and SFH-2

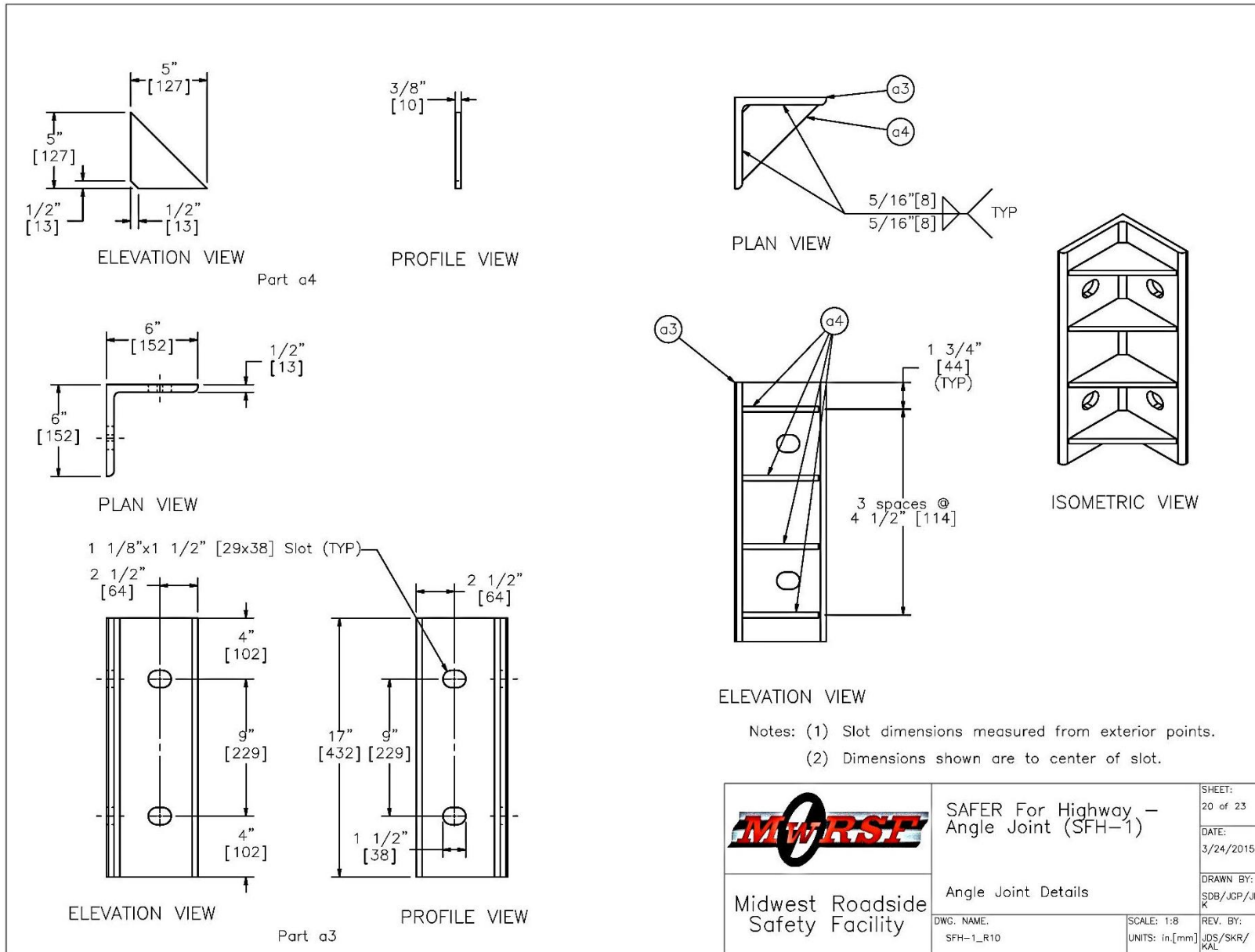
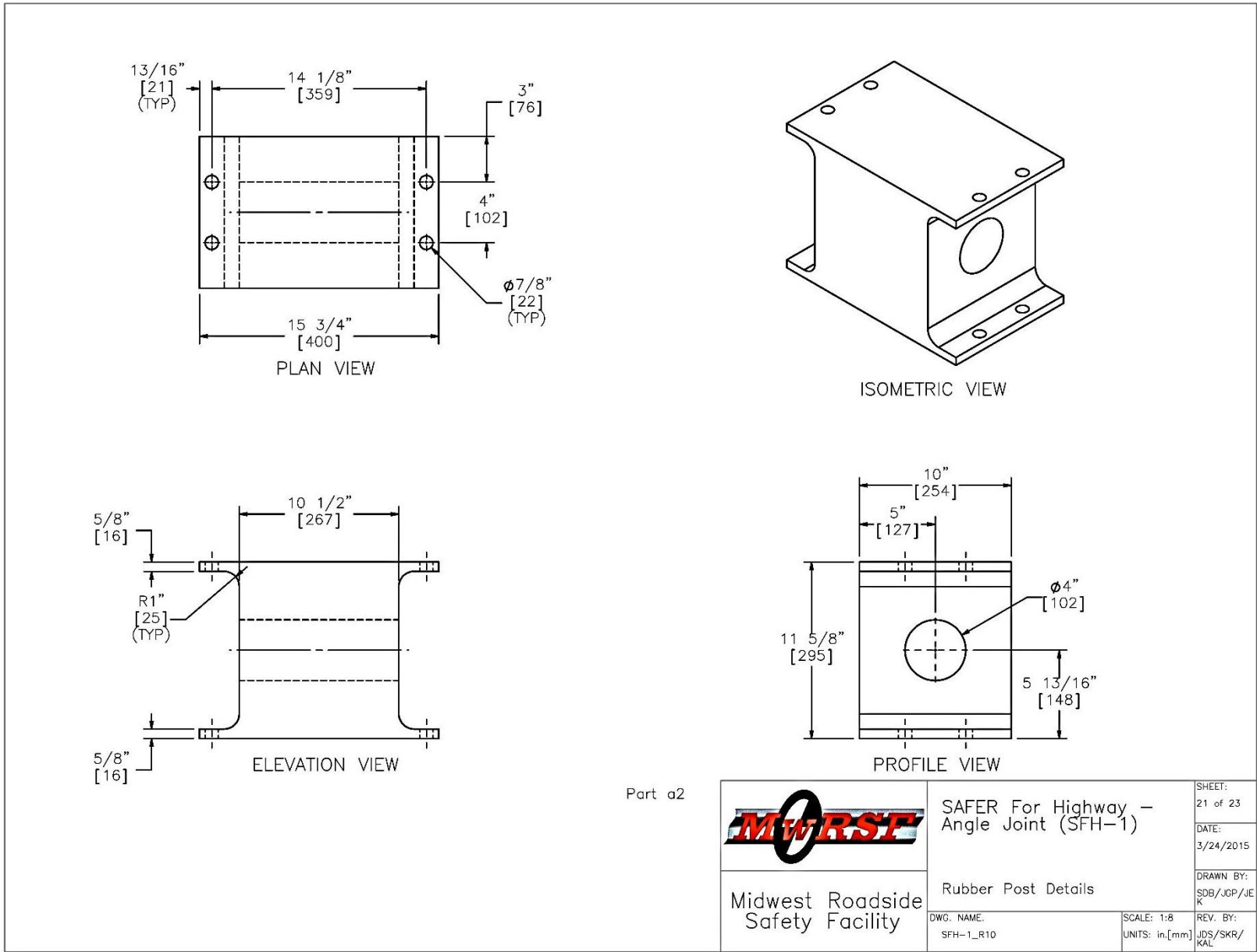

Figure 21. Angle Joint Details, Test Nos. SFH-1 and SFH-2



Part a2

	SAFER For Highway – Angle Joint (SFH-1)		SHEET: 21 of 23
	Rubber Post Details		DATE: 3/24/2015
Midwest Roadside Safety Facility	DWG. NAME: SFH-1_R10	SCALE: 1:8 UNITS: in,[mm]	DRAWN BY: SDB/JCP/JEK REV. BY: JDS/SKR/KAL

Figure 22. Rubber Post Details, Test Nos. SFH-1 and SFH-2

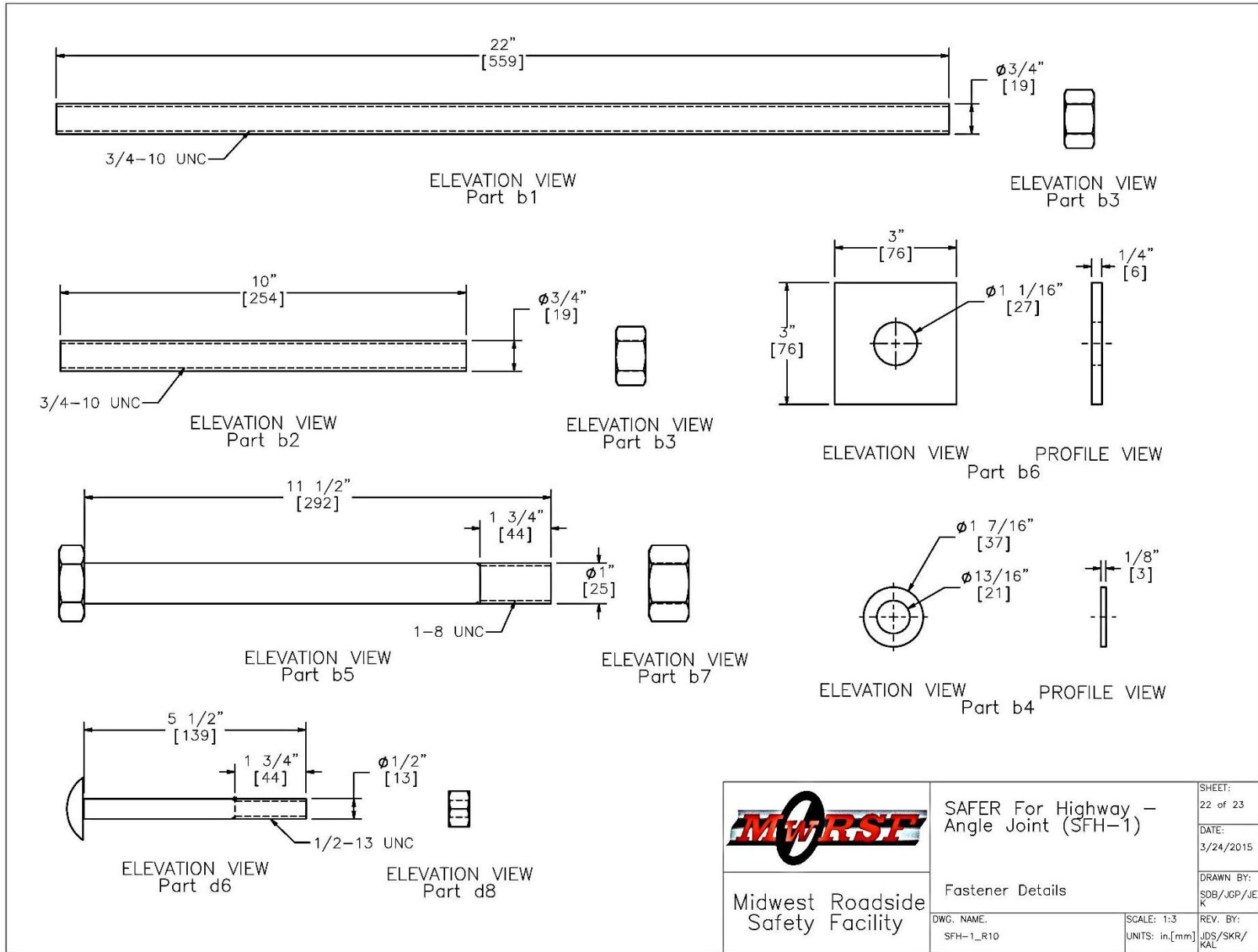

Midwest Roadside Safety Facility

SAFER For Highway – Angle Joint (SFH-1)		SHEET: 22 of 23
Fastener Details		DATE: 3/24/2015
DRAWN BY: SDB/JCP/JEK		REV. BY: JDS/SKR/KAL
DWG. NAME: SFH-1_R10	SCALE: 1:3 UNITS: in,[mm]	

Figure 23. Fastener Details, Test Nos. SFH-1 and SFH-2

Item No.	QTY.	Description	Material Specification	Hardware Guide
a1	12	Lightweight Concrete Rail	min f'c=5 ksi [34.5 MPa], density=110 pcf	-
a2	48	Morse E46496 Shear Fender	ASTM D2000	-
a3	22	6"x6"x1/2" [152x152x13], 17" [432] Long L-Bracket	A992 Galvanized	-
a4	88	5"x5"x3/8" [127x127x10] Gusset Plate	A572 Grade 50 Galvanized	-
b1	192	3/4" [19] Dia. UNC, 22" [559] Long Threaded Rod	ASTM A193 Grade B7 Galvanized	-
b2	192	3/4" [19] Dia. UNC, 10" [254] Long Threaded Rod	ASTM A193 Grade B7 Galvanized	-
b3	576	3/4" [19] Dia. UNC Heavy Hex Nut	ASTM A194 Grade 2H Galv.	-
b4	576	3/4" [19] Dia. Flat Washer	ASTM F436 Galv.	FWC20b
b5	88	1" [25] Dia. UNC, 11 1/2" [292] Long Hex Head Bolt	ASTM A325 Galv.	FBX24b
b6	176	3"x3"x1/4" [76x76x6] Square Washer	A572 Grade 50 Galvanized	-
b7	88	1" [25] Dia. UNC Heavy Hex Nut	ASTM A563 DH Galv.	FNX24b
c1	336	1/2" [13] Dia., 77" [1956] Long Bent Rebar	A615 Grade 60	-
c2	96	1/2" [13] Dia., 49" [1245] Long Bent Rebar	A615 Grade 60	-
c3	144	3/4" [19] Dia., 231" [5867] Long Rebar	A615 Grade 60	-
c4	96	3/4" [19] Dia., 63" [1600] Long Bent Rebar	A615 Grade 60	-
c5	72	3/4" [19] Dia., 69" [1753] Long Bent Rebar	A615 Grade 60	-
d1	48	17"x8"x1/2" [432x203x13] Anchor Plate	ASTM A572 Grade 50 Galvanized	-
d2	48	4"x4"x1/4" [102x102x6], 4" [102] Long Tube	A500 Grade B Galvanized	-
d3	11	8"x4"x1/4" [203x102x6], 239 1/2" [6083] Long Tube	A500 Grade B Galvanized	-
d4	2	8"x4"x1/4" [203x102x6], 119 1/2" [3035] Long End Tube	A500 Grade B Galvanized	-
d5	12	12 3/4"x6 1/2"x3/16" [324x165x5] Bent Plate	ASTM A572 Grade 50 Galvanized	-
d6	24	1/2" [13] Dia. UNC, 5 1/2" [140] Long Dome (Round) Head Bolt	ASTM A307 Grade A Galvanized	-
d7	24	1/2" [13] Dia. Flat Washer	ASTM F844 Galvanized	FWC12a
d8	24	1/2" [13] Dia. UNC Heavy Hex Nut	A563A Galvanized	FNX12b
d9	-	Epoxy	HILTI HIT-RE500	-
e1	24	6 1/2" [165] Dia., 3/8" [10] Thick, 19" [483] Long Steel Pipe	AISI 1026	-
e2	24	16 9/16"x10"x1/4" [421x254x6] Base Plate	ASTM A572 Grade 50 Steel	-
e3	48	3 1/2"x10 3/8"x1/2" [89x264x13] Plate Gusset	ASTM A572 Grade 50 Steel	-
e4	24	12"x12"x3/8" [305x305x10] Top Plate	ASTM A572 Grade 50 Steel	-
e5	24	12"x12"x1/2" [305x305x13] EPDM Rubber Sheet	Minimum 50 durometer	-

 Midwest Roadside Safety Facility	SAFER For Highway - Angle Joint (SFH-1)	SHEET: 23 of 23 DATE: 3/24/2015 DRAWN BY: SDB/JGP/JEK REV. BY: JDS/SKR/ KAL
	Bill of Materials	DWG. NAME: SFH-1_R10 SCALE: 1:8 UNITS: in,[mm]

Figure 24. Bill of Materials, Test Nos. SFH-1 and SFH-2

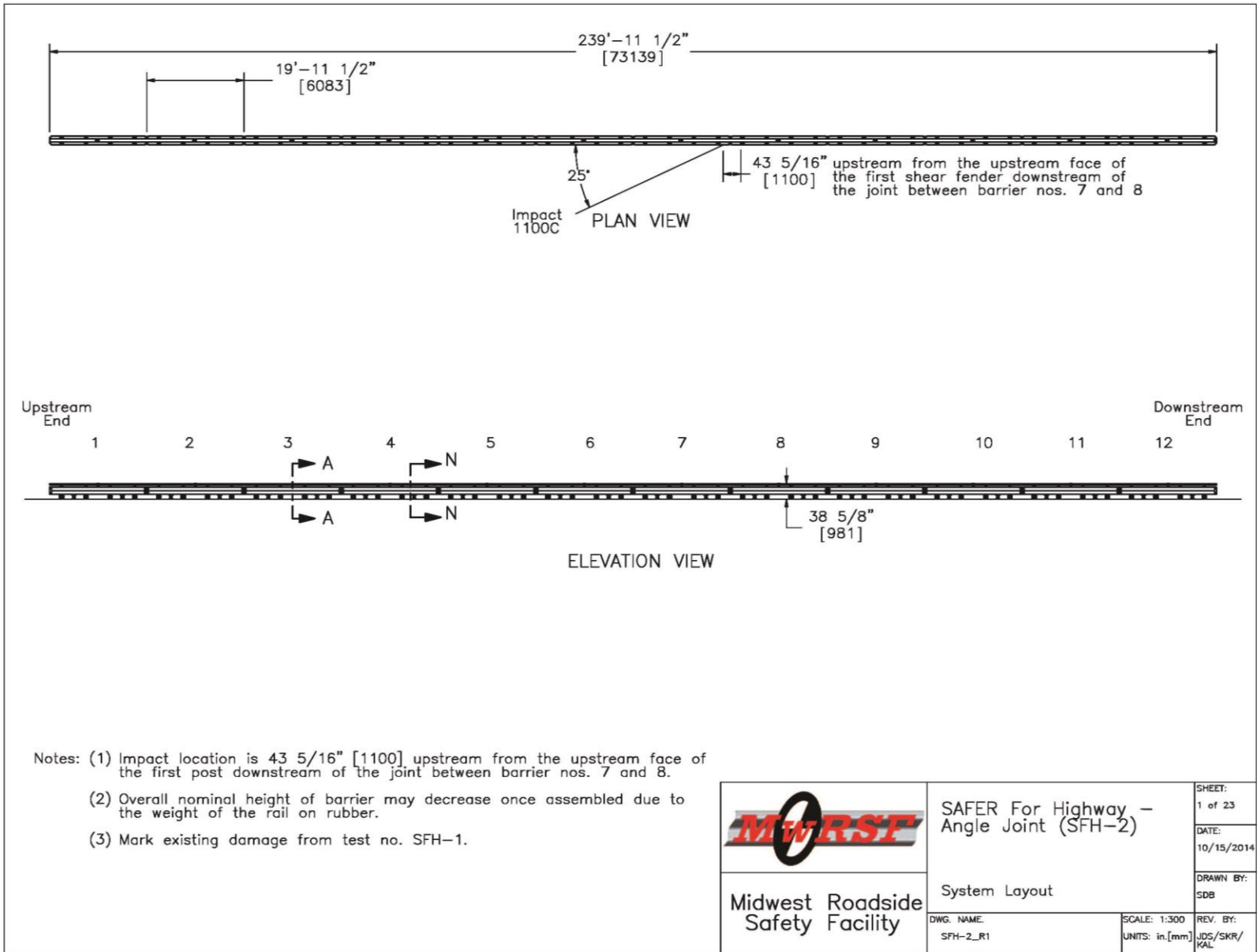

Figure 25. System Layout, Test No. SFH-2



Figure 26. Test Installation Photographs, Test Nos. SFH-1 through SFH-2



Figure 27. Test Installation Photographs, Adjustable Continuity Joint, Test Nos. SFH-1 through SFH-2



Figure 28. Test Installation Photographs, Skids and Upper Tube Assembly Splices, Test Nos. SFH-1 through SFH-2

3 TEST REQUIREMENTS AND EVALUATION CRITERIA

3.1 Test Requirements

Longitudinal barriers, such as concrete barriers, must satisfy impact safety standards in order to be eligible for reimbursement by the Federal Highway Administration (FHWA) for use on the National Highway System (NHS). For new hardware, these safety standards consist of the guidelines and procedures published in MASH [4]. According to TL-4 of MASH, longitudinal barrier systems must be subjected to three full-scale vehicle crash tests, as summarized in Table 1.

Table 1. MASH TL-4 Crash Test Conditions for Longitudinal Barriers [4]

Test Article	Test Designation No.	Test Vehicle	Vehicle Weight, lb (kg)	Impact Conditions		Evaluation Criteria ¹
				Speed, mph (km/h)	Angle, deg.	
Longitudinal Barrier	4-10	1100C	2,425 (1,100)	62 (100)	25	A,D,F,H,I
	4-11	2270P	5,000 (2,270)	62 (100)	25	A,D,F,H,I
	4-12	10000S	22,000 (10,000)	56 (90)	15	A, D, G

¹ Evaluation criteria explained in Table 2.

3.2 Evaluation Criteria

Evaluation criteria for full-scale vehicle crash testing are based on three appraisal areas: (1) structural adequacy; (2) occupant risk; and (3) vehicle trajectory after collision. Criteria for structural adequacy are intended to evaluate the ability of the median barrier to contain and redirect impacting vehicles. In addition, controlled lateral deflection of the test article is acceptable. Occupant risk evaluates the degree of hazard to occupants in the impacting vehicle but is not required by MASH for non-passenger vehicle impacts. Post-impact vehicle trajectory

is a measure of the potential of the vehicle to result in a secondary collision with other vehicles and/or fixed objects, thereby increasing the risk of injury to the occupants of the impacting vehicle and/or other vehicles. These evaluation criteria are summarized in Table 2 and defined in greater detail in MASH. The full-scale vehicle crash tests were conducted and reported in accordance with the procedures provided in MASH.

In addition to the standard occupant risk measures, the Post-Impact Head Deceleration (PHD), the Theoretical Head Impact Velocity (THIV), and the Acceleration Severity Index (ASI) were determined and reported on the test summary sheet. Additional discussion on PHD, THIV and ASI is provided in MASH.

Table 2. MASH Evaluation Criteria for Longitudinal Barrier

Structural Adequacy	A. Test article should contain and redirect the vehicle or bring the vehicle to a controlled stop; the vehicle should not penetrate, underride, or override the installation although controlled lateral deflection of the test article is acceptable.			
Occupant Risk	D. Detached elements, fragments or other debris from the test article should not penetrate or show potential for penetrating the occupant compartment, or present an undue hazard to other traffic, pedestrians, or personnel in a work zone. Deformations of, or intrusions into, the occupant compartment should not exceed limits set forth in Section 5.3 and Appendix E of MASH.			
	F. The vehicle should remain upright during and after collision. The maximum roll and pitch angles are not to exceed 75 degrees.			
	G. It is preferable, although not essential, that the vehicle remain upright during and after collision.			
	H. Occupant Impact Velocity (OIV) (see Appendix A, Section A5.3 of MASH for calculation procedure) should satisfy the following limits:			
	Occupant Impact Velocity Limits			
	Component		Preferred	Maximum
	Longitudinal and Lateral		30 ft/s (9.1 m/s)	40 ft/s (12.2 m/s)
I. The Occupant Ridedown Acceleration (ORA) (see Appendix A, Section A5.3 of MASH for calculation procedure) should satisfy the following limits:	Occupant Ridedown Acceleration Limits			
Component		Preferred	Maximum	
Longitudinal and Lateral		15.0 g's	20.49 g's	

4 TEST CONDITIONS

4.1 Test Facility

The testing facility was located at the Lincoln Air Park on the northwest side of the Lincoln Municipal Airport and is approximately 5 miles (8.0 km) northwest of the University of Nebraska-Lincoln city campus.

4.2 Vehicle Tow and Guidance System

A reverse cable tow system with a 1:2 mechanical advantage was used to propel the test vehicle. The distance traveled and the speed of the tow vehicle were one-half those of the test vehicle. The test vehicle was released from the tow cable before impact with the barrier system. A digital speedometer on the tow vehicle increased the accuracy of the recorded test vehicle impact speed.

A vehicle guidance system developed by Hinch [5] was used to steer the test vehicle. A guide flag, attached to the left-front wheel and the guide cable for test nos. SFH-1 through SFH-3, was sheared off before impact with the barrier system. The $\frac{3}{8}$ -in. (10-mm) diameter guide cable was tensioned to approximately 3,500 lb (15.6 kN) and supported both laterally and vertically every 100 ft (30.5 m) by hinged stanchions. The hinged stanchions stood upright while holding up the guide cable, but as the vehicle was towed down the line, the guide flag struck and knocked each stanchion to the ground.

4.3 Test Vehicles

For test no. SFH-1, a 2005 Dodge Ram 1500 was used as the test vehicle. The curb, test inertial, and gross static vehicle weights were 5,094 lb (2,311 kg), 5,021 lb (2,277 kg), and 5,186 lb (2,352 kg), respectively. The test vehicle is shown in Figure 29, and vehicle dimensions are shown in Figure 30.

For test no. SFH-2, a 2005 Kia Rio was used as the test vehicle. The curb, test inertial, and gross static vehicle weights were 2,406 lb (1,091 kg), 2,406 lb (1,091 kg), and 2,572 lb (1,167 kg), respectively. The test vehicle is shown in Figure 31, and vehicle dimensions are shown in Figure 32.

For test no. SFH-3, a 1998 Ford F-800 was used as the test vehicle. The curb, test inertial, and gross static vehicle weights were 11,180 lb (5,071 kg), 21,746 lb (9,864 kg), and 21,912 lb (9,939 kg), respectively. The test vehicle is shown in Figure 31, and vehicle dimensions are shown in Figure 33.

The longitudinal component of the center of gravity (c.g.) was determined using the measured axle weights for all three tests. The Suspension Method [6] was used to determine the vertical component of the c.g. for the pickup truck. This method is based on the principle that the c.g. of any freely suspended body is in the vertical plane through the point of suspension. The vehicle was suspended successively in three positions, and the respective planes containing the c.g. were established. The intersection of these planes pinpointed the final c.g. location for the test inertial condition. The vertical component of the c.g. for the 1100C vehicle was determined utilizing a procedure published by SAE [7]. The Elevated Axle Method [8] was used to determine the vertical component of the c.g. for the 10000S vehicle. This method converts measured wheel weights at different elevations to the location of the vertical component of the c.g. The location of the final c.g. for test no. SFH-1 is shown in Figures 30 and 35. The location of the final c.g. for test no. SFH-2 is shown in Figures 32 and 36. The location of the final c.g. for test no. SFH-3 is shown in Figures 34 and 37. Data used to calculate the locations of the c.g. are shown in Appendix B.

Square, black- and white-checked targets were placed on the vehicles for reference to be viewed from the high-speed digital video cameras and aid in the video analysis, as shown in

Figures 35 through 37. Round, checkered targets were placed on the centers of gravity on the left-side, the right-side, and the roof of each vehicle.

The front wheels of each test vehicle were aligned to vehicle standards, except the toe-in value was adjusted to zero so that the vehicles would track properly along the guide cable. A 5B flash bulb was mounted on the left side of each vehicle's dash and was fired by a pressure tape switch mounted at the impact corner of the bumper. The flash bulb was fired upon initial impact with the test article to create a visual indicator of the precise time of impact on the high-speed videos. A remote-controlled brake system was installed in each test vehicle so the vehicles could be brought safely to a stop after each test.

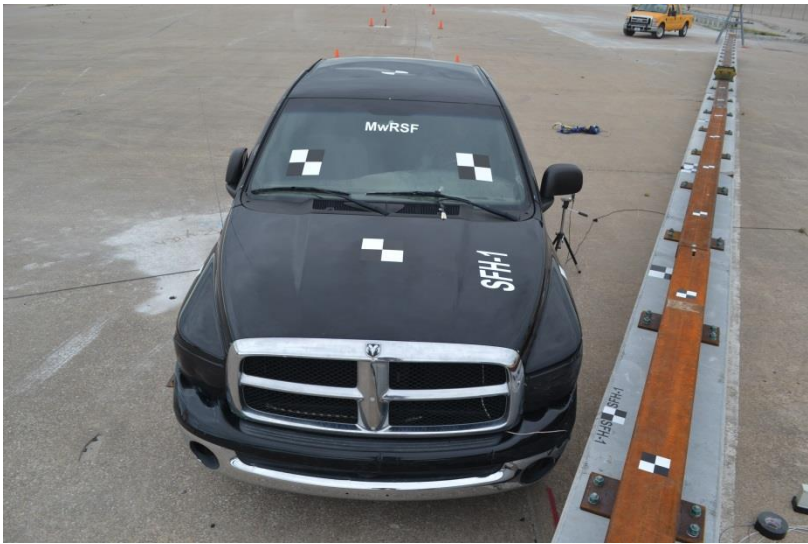

Figure 29. Test Vehicle, Test No. SFH-1

Date: 7/2/2014 Test Number: SFH-1 Model: Ram 1500 QC

Make: Dodge Vehicle I.D.#: 1D7HA18N05J560193

Tire Size: 265/70 R17 Year: 2005 Odometer: 147869

Tire Inflation Pressure: 35psi

*(All Measurements Refer to Impacting Side)

Vehicle Geometry -- in. (mm)

a	<u>78</u>	<u>(1981)</u>	b	<u>75</u>	<u>(1905)</u>
c	<u>227 3/4</u>	<u>(5785)</u>	d	<u>48</u>	<u>(1219)</u>
e	<u>140 1/4</u>	<u>(3562)</u>	f	<u>39 1/2</u>	<u>(1003)</u>
g	<u>28 6/7</u>	<u>(733)</u>	h	<u>63 3/5</u>	<u>(1616)</u>
i	<u>16</u>	<u>(406)</u>	j	<u>26</u>	<u>(660)</u>
k	<u>22 1/2</u>	<u>(572)</u>	l	<u>28 3/4</u>	<u>(730)</u>
m	<u>68 1/8</u>	<u>(1730)</u>	n	<u>140 1/4</u>	<u>(3562)</u>
o	<u>44</u>	<u>(1118)</u>	p	<u>3 1/2</u>	<u>(89)</u>
q	<u>31</u>	<u>(787)</u>	r	<u>18 1/2</u>	<u>(470)</u>
s	<u>15</u>	<u>(381)</u>	t	<u>75 1/2</u>	<u>(1918)</u>

Wheel Center Height Front 14 3/4 (375)

Wheel Center Height Rear 15 (381)

Wheel Well Clearance (F) 35 1/4 (895)

Wheel Well Clearance (R) 37 1/2 (953)

Frame Height (F) 18 1/4 (464)

Frame Height (R) 24 3/4 (629)

Engine Type 8cyl. Gas

Engine Size 4.7L

Transmission Type:

Automatic ~~Manual~~

FWD RWD 4WD

Mass Distribution lb (kg)

Gross Static	LF	<u>1449</u>	<u>(657)</u>	RF	<u>1394</u>	<u>(632)</u>
	LR	<u>1206</u>	<u>(547)</u>	RR	<u>1137</u>	<u>(516)</u>

Weights lb (kg)

	Curb	Test Inertial	Gross Static			
W-front	<u>2819</u>	<u>(1279)</u>	<u>2744</u>	<u>(1245)</u>	<u>2843</u>	<u>(1290)</u>
W-rear	<u>2275</u>	<u>(1032)</u>	<u>2277</u>	<u>(1033)</u>	<u>2343</u>	<u>(1063)</u>
W-total	<u>5094</u>	<u>(2311)</u>	<u>5021</u>	<u>(2277)</u>	<u>5186</u>	<u>(2352)</u>

GVWR Ratings

Front	<u>3650</u>
Rear	<u>3900</u>
Total	<u>6650</u>

Dummy Data

Type: Hybrid II

Mass: 165lbs

Seat Position: Driver

Note any damage prior to test: Passenger side damage from NYCC-1 impact.

Figure 30. Vehicle Dimensions, Test No. SFH-1



Figure 31. Test Vehicle, Test No. SFH-2

Date: 8/11/2014 Test Number: SFH-2 Model: RIO
Make: KIA Vehicle I.D.#: KNADC125356357567
Tire Size: P175/65R14 Year: 2005 Odometer: 84386
Tire Inflation Pressure: 30 psi
*(All Measurements Refer to Impacting Side)

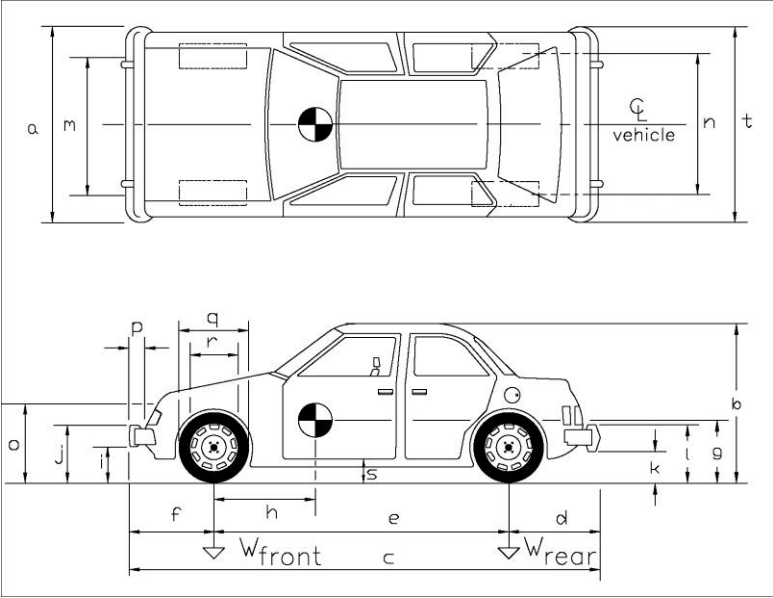

Vehicle Geometry -- in. (mm)

a	<u>65 1/2 (1664)</u>	b	<u>55 1/2 (1410)</u>
c	<u>166 1/2 (4229)</u>	d	<u>38 (965)</u>
e	<u>95 1/4 (2419)</u>	f	<u>33 1/4 (845)</u>
g	<u>19 (483)</u>	h	<u>36 1/4 (921)</u>
i	<u>8 1/2 (216)</u>	j	<u>21 (533)</u>
k	<u>8 1/2 (216)</u>	l	<u>22 (559)</u>
m	<u>55 1/2 (1410)</u>	n	<u>95 1/4 (2419)</u>
o	<u>27 1/4 (692)</u>	p	<u>3 1/2 (89)</u>
q	<u>22 3/4 (578)</u>	r	<u>15 1/4 (387)</u>
s	<u>13 (330)</u>	t	<u>64 1/4 (1632)</u>

Wheel Center Height Front 10 5/8 (270)
Wheel Center Height Rear 11 (279)
Wheel Well Clearance (F) 23 3/4 (603)
Wheel Well Clearance (R) 24 1/4 (616)
Frame Height (F) 6 3/4 (171)
Frame Height (R) 16 1/2 (419)
Engine Type 4cyl. Gas
Engine Size 1.6L
Transmission Type:
 Automatic Manual
 FWD RWD 4WD

Mass Distribution lb (kg)

Gross Static	LF	<u>796 (361)</u>	RF	<u>776 (352)</u>
	LR	<u>519 (235)</u>	RR	<u>481 (218)</u>
				<u>95.25</u>

Weights lb (kg)

	Curb	Test Inertial	Gross Static
W-front	<u>1533 (695)</u>	<u>1490 (676)</u>	<u>1572 (713)</u>
W-rear	<u>873 (396)</u>	<u>916 (415)</u>	<u>1000 (454)</u>
W-total	<u>2406 (1091)</u>	<u>2406 (1091)</u>	<u>2572 (1167)</u>

GVWR Ratings

Front	<u>1808</u>
Rear	<u>1742</u>
Total	<u>3399</u>

Dummy Data

Type: Hybrid 1
Mass: 166 lbs.
Seat Position: Driver

Note any damage prior to test: None

Figure 32. Vehicle Dimensions, Test No. SFH-2



Figure 33. Test Vehicle, Test No. SFH-3

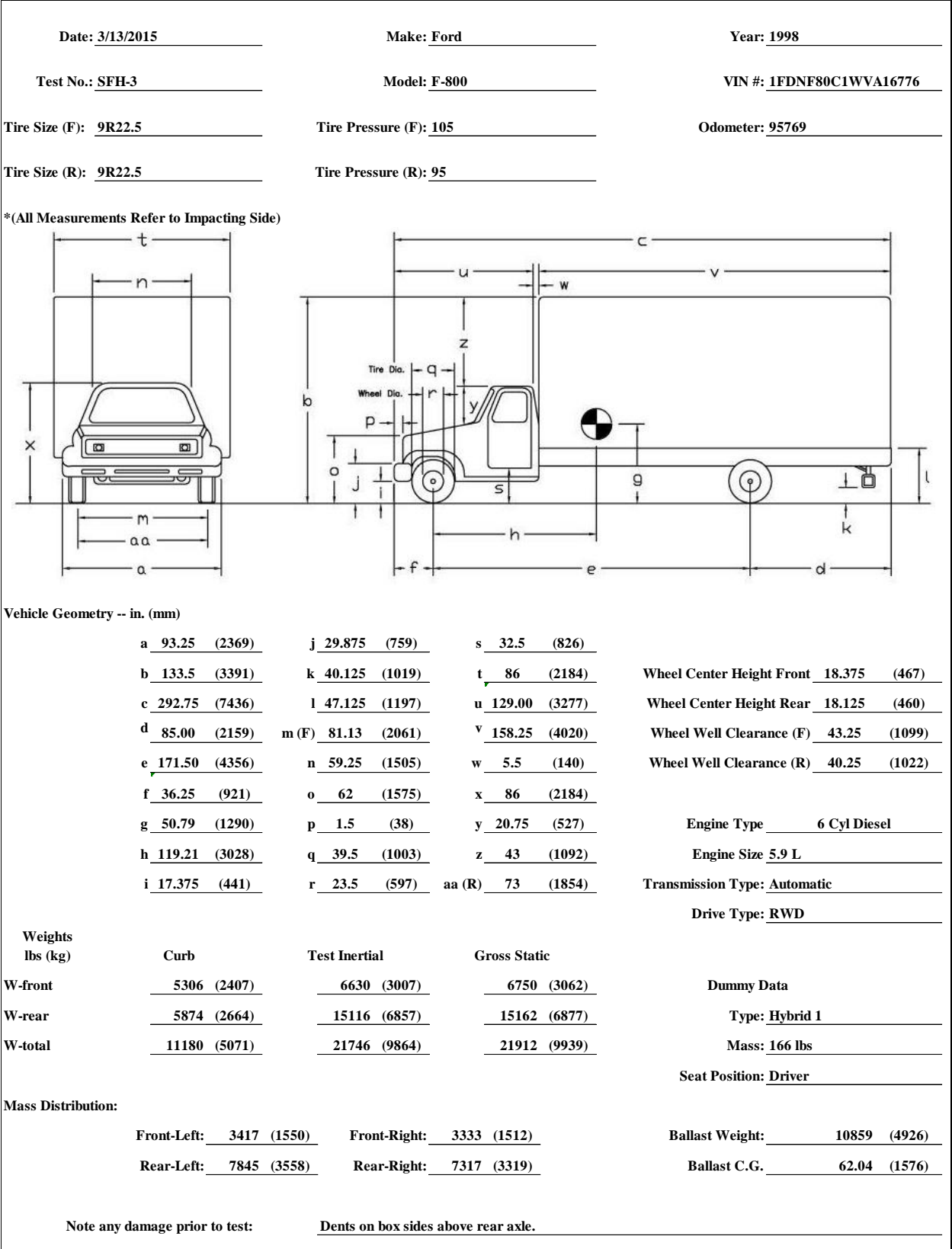

Figure 34. Vehicle Dimensions, Test No. SFH-3

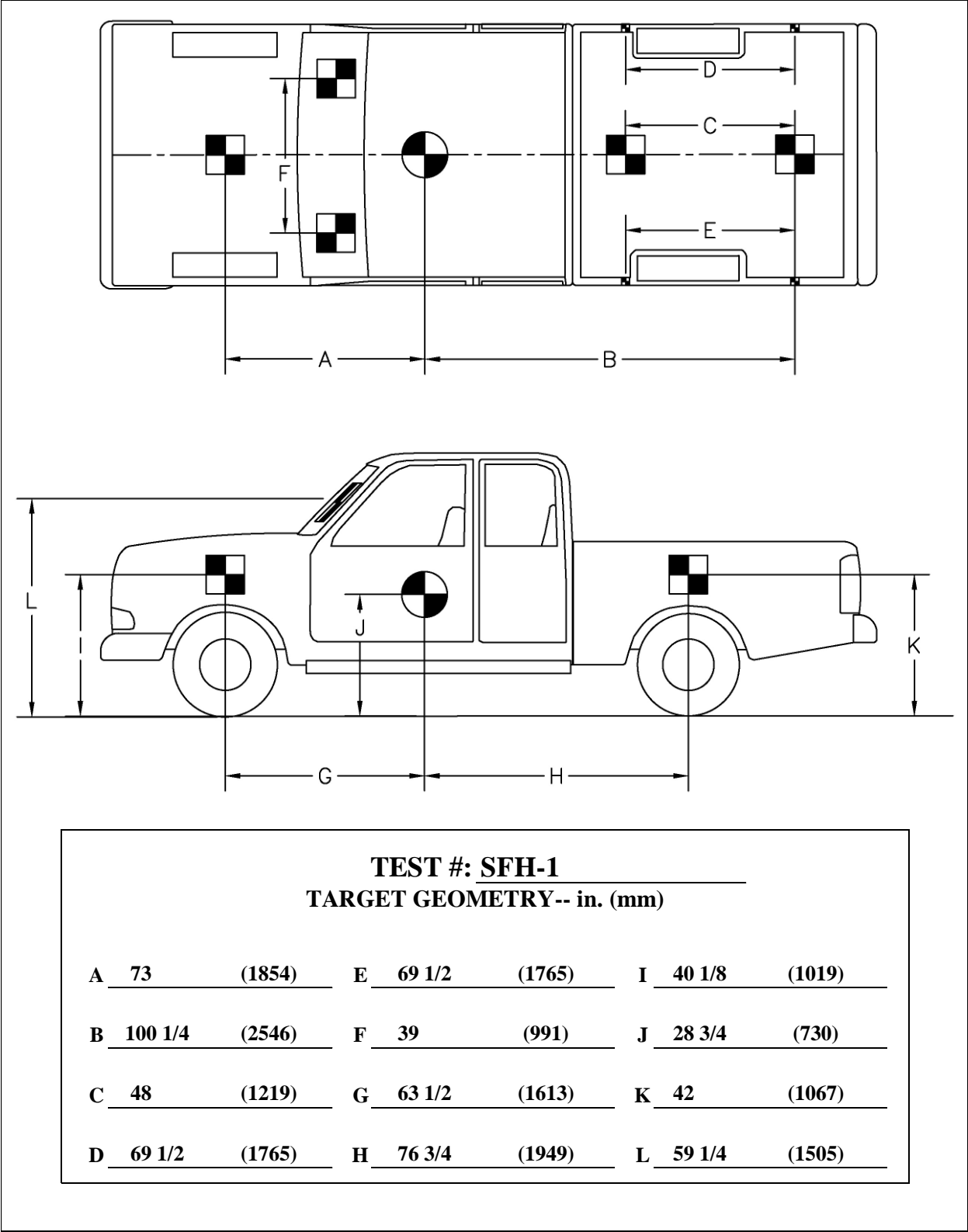

Figure 35. Target Geometry, Test No. SFH-1

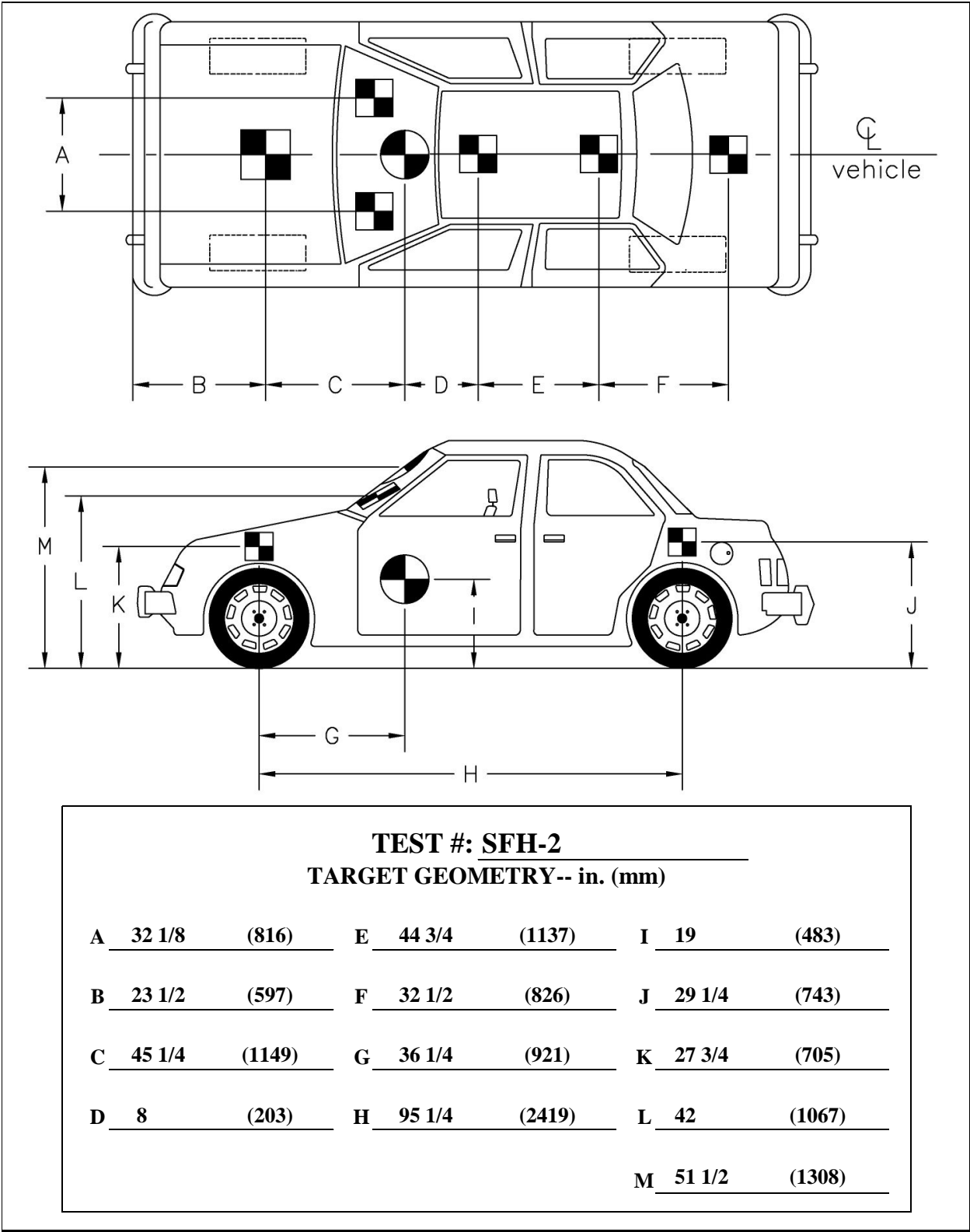
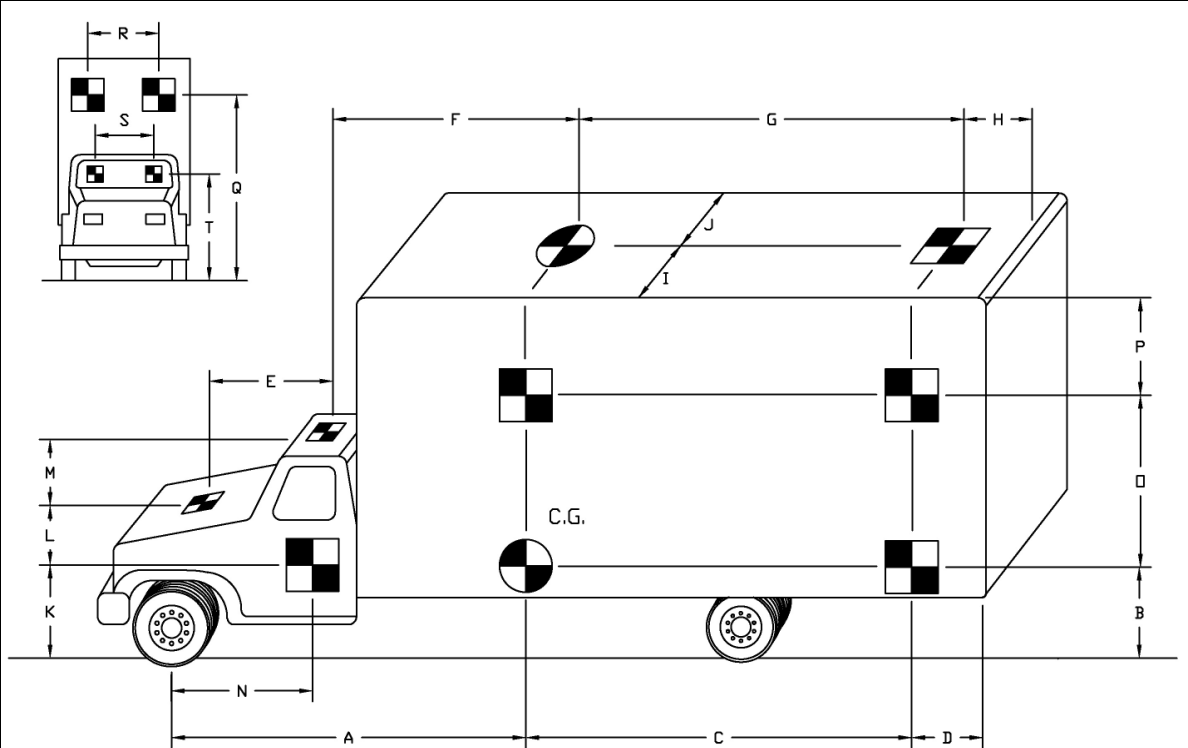

Figure 36. Target Geometry, Test No. SFH-2



TEST #: <u>SFH-3</u>		Vehicle: <u>Ford F-800</u>	
TARGET GEOMETRY-- in. (mm)			
8 inch Square Targets			
A	<u>89.25 (2267)</u>	H	<u>16 (406)</u>
B	<u>63.5 (1613)</u>	I	<u>48 (1219)</u>
C	<u>140.75 (3575)</u>	J	<u>48 (1219)</u>
D	<u>16 (406)</u>	K	<u>46.5 (1181)</u>
E	<u>58.375 (1483)</u>	L	<u>17.75 (451)</u>
F	<u>70.5 (1791)</u>	M	<u>21.5 (546)</u>
G	<u>110.5 (2807)</u>	N	<u>41.75 (1060)</u>
C.G. Targets (round targets)			
A	<u>119.25 (3029)</u>	F	<u>70.5 (1791)</u>
B	<u>50.375 (1280)</u>	G	<u>110.5 (2807)</u>
C	<u>111.5 (2832)</u>	I	<u>48 (1219)</u>

Figure 37. Target Geometry, Test No. SFH-3

In test no. SFH-3 the van body was attached according to the “2005 Ford Body Builder Layout Book” [9] as recommended in MASH. The left and right frame rails were set up symmetrically. All of the measurements during installation were taken from the end of the factory frame at the rear of the vehicle, noted from front to back. A total of four shear plates were attached to the frame for extra support. The front shear plates were 4-in. x 17-in. x $\frac{3}{8}$ -in. (102-mm x 432-mm x 10-mm) mounted at a 50 degree angle from horizontal with the top ahead of the bottom and the back shear plates were installed 130 in. (3,302 mm) from the rear end of the frame, as shown in Figure 38. The front shear plates were connected with one $\frac{5}{8}$ -in. (16-mm) diameter bolt through the van body subframe and two $\frac{5}{8}$ -in. (16-mm) diameter bolts through the truck frame. The rear shear plates were 6-in. x 14-in. x $\frac{3}{8}$ -in. (152-mm x 356-mm x 10-mm) mounted in the vertical position. The rear shear plates were connected with one $\frac{5}{8}$ -in. (16-mm) diameter bolt through the van body subframe and three $\frac{5}{8}$ -in. (16-mm) diameter bolts through the truck frame. The subframe was welded to the flat edge sections of the shear plate and not in the corners. The truck frame was not welded. Six U-bolts were installed for additional strength. The U-bolts were installed 124 in. (3,150 mm), 90 in. (2,286 mm), and 32 in. (813 mm) from the rear. These bolts were $\frac{5}{8}$ -in. (16-mm) diameter with 6-in. x 1½-in. x ½-in. (152-mm x 38-mm x 13-mm) steel caps. In addition, wood crush blocks were installed along the vertical length of the open side of the c-channel frame at the U-bolt locations to keep the frame from crushing under the load of the U-bolts.

In test no. SFH-3, 10,859 lb (4,926 kg) of ballast was added to the van body. Two safety shape concrete barriers and twenty-one steel plates were attached to the van floor. The concrete barriers were each attached through the floor and to the subframe with six 1¼-in. (32-mm) diameter threaded rods. Thirteen rectangular, 33-lb (15-kg), steel plates were attached with four ½-in. (13-mm) diameter threaded rods, and eight circular, 45-lb (20-kg), steel plates were each

attached with one 1¼-in. (32-mm) diameter threaded rod through the center of the plates. The ballast was symmetrical with the exception of one additional plate on the non-impact side of the cargo box, as shown in Figure 39. Foam blocks were used to stabilize the concrete barriers during impact.

4.4 Simulated Occupant

For test nos. SFH-1 through SFH-3, a Hybrid II 50th-Percentile Adult Male Dummy, equipped with clothing and footwear, was placed in the left-front seat of the test vehicle with the seat belt fastened. The dummy, which had final weights of 165, 166 and 166 lb (75, 75, and 75 kg) for test nos. SFH-1 through SFH-3, respectively, was represented by model no. 572, serial no. 451, and was manufactured by Android Systems of Carson, California. As recommended by MASH, the dummy was not included in calculating the c.g location.

4.5 Data Acquisition Systems

4.5.1 Accelerometers

Two environmental shock and vibration sensor/recorder systems were used to measure the accelerations in the longitudinal, lateral, and vertical directions for test nos. SFH-1 through SFH-3 and were mounted near the centers of gravity of the test vehicles. An additional environmental shock and vibration sensor/recorder system was used for test no. SFH-3 and was mounted inside the cab of the single-unit truck. The electronic accelerometer data obtained in dynamic testing was filtered using the SAE Class 60 and the SAE Class 180 Butterworth filter conforming to the SAE J211/1 specifications [10].



Right-Rear Shear Plate



Right-Front Shear Plate and U-Bolt

Figure 38. Shear Plate and U-Bolt Installation, Test No. SFH-3



Figure 39. Ballast Installation, Test No. SFH-3

The two accelerometer systems used in all three tests, the SLICE-1 and SLICE-2 units, were modular data acquisition systems manufactured by Diversified Technical Systems, Inc. (DTS) of Seal Beach, California. The acceleration sensors were mounted inside the bodies of custom-built SLICE 6DX event data recorders and recorded data at 10,000 Hz to the onboard microprocessor. Each SLICE 6DX was configured with 7 GB of non-volatile flash memory, a range of ± 500 g's, a sample rate of 10,000 Hz, and a 1,650 Hz (CFC 1000) anti-aliasing filter. The "SLICEWare" computer software program and a customized Microsoft Excel worksheet were used to analyze and plot the accelerometer data.

The additional system used in test no. SFH-3 was a two-arm piezoresistive accelerometer system manufactured by Meggitt, Inc. of San Juan Capistrano, California. Three accelerometers were used to measure each of the longitudinal, lateral, and vertical accelerations independently at a sample rate of 10,000 Hz. The accelerometers were configured and controlled using a system developed and manufactured by DTS. More specifically, data was collected using a DTS Sensor Input Module (SIM), Model TDAS3-SIM-16M. The SIM was configured with 16 MB SRAM and eight sensor input channels with 250 kB SRAM/channel. The SIM was mounted on a TDAS3-R4 module rack. The module rack was configured with isolated power/event/communications, 10BaseT Ethernet and RS232 communication, and an internal backup battery. Both the SIM and module rack were crashworthy. The "DTS TDAS Control" computer software program and a customized Microsoft Excel worksheet were used to analyze and plot the accelerometer data.

4.5.2 Rate Transducers

Two identical angle rate sensor systems mounted inside the bodies of the SLICE-1 and SLICE-2 event data recorders were used to measure the rates of rotation of the test vehicles in test nos. SFH-1 through SFH-3. Each SLICE MICRO Triax ARS had a range of 1,500

degrees/sec in each of the three directions (roll, pitch, and yaw) and recorded data at 10,000 Hz to the onboard microprocessors. The raw data measurements were then downloaded, converted to the proper Euler angles for analysis, and plotted. The “SLICEWare” computer software program and a customized Microsoft Excel worksheet were used to analyze and plot the angular-rate sensor data.

A third angle rate sensor, the ARS-1500, with a range of 1,500 degrees/sec in each of the three directions (roll, pitch, and yaw) was used to measure the rates of rotation of the test vehicle in test no. SFH-3. The angular-rate sensor was mounted on an aluminum block inside the test vehicle and recorded data at 10,000 Hz to the DTS SIM. The raw data measurements were then downloaded, converted to the proper Euler angles for analysis, and plotted. The “DTS TDAS Control” computer software program and a customized Microsoft Excel worksheet were used to analyze and plot the angular rate sensor data.

4.5.3 Load Cells

Load cells were placed on the front and back bolts supporting the ACJ just downstream of impact, but were not reported herein due to the accuracy of the data unable to be validated.

4.5.4 Retroreflective Optic Speed Trap

A retroreflective optic speed trap was used to determine the speed of the test vehicles before impact. Five retroreflective targets, spaced at approximately 18-in. (457-mm) intervals, were applied to the side of each vehicle. When the emitted beam of light was reflected by the targets and returned to the Emitter/Receiver, a signal was sent to the data acquisition computer, recording at 10,000 Hz, as well as the external LED box activating the LED flashes. The speed was then calculated using the spacing between the retroreflective targets and the time between the signals. LED lights and high-speed digital video analysis are only used as a backup in the event that vehicle speeds cannot be determined from the electronic data.

4.5.5 Digital Photography

Six AOS high-speed digital video cameras, four GoPro digital video cameras, and four JVC digital video cameras were utilized to film test no. SFH-1. Camera details, camera operating speeds, lens information, and a schematic of the camera locations relative to the system are shown in Figure 40. Camera JVC-2 did not function due to technical difficulties.

Six AOS high-speed digital video cameras, five GoPro digital video cameras, and three JVC digital video cameras were utilized to film test no. SFH-2. Camera details, camera operating speeds, lens information, and a schematic of the camera locations relative to the system are shown in Figure 41.

Six AOS high-speed digital video cameras, seven GoPro digital video cameras, and three JVC digital video cameras were utilized to film test no. SFH-3. Camera details, camera operating speeds, lens information, and a schematic of the camera locations relative to the system are shown in Figure 42. Cameras AOS-6 and GP-4 did not function due to technical difficulties.

The high-speed videos were analyzed using ImageExpress MotionPlus and RedLake MotionScope software programs. Actual camera speed and camera divergence factors were considered in the analysis of the high-speed videos. A Nikon D50 digital still camera was used to document pre- and post-test conditions for all tests.

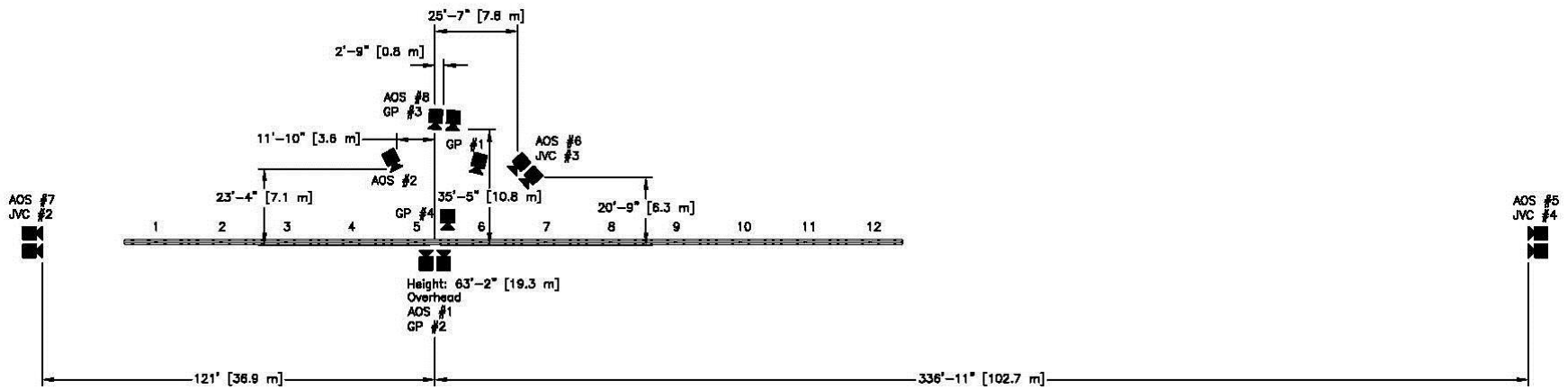

56

No.	Type	Operating Speed (frames/sec)	Lens	Lens Setting
AOS-1	AOS Vitcam CTM	500	Cosmicar 12.5mm Fixed	
AOS-2	AOS Vitcam	500	Sigma 28-70	35
AOS-5	AOS X-PRI Gigabit	500	Canon TV Zoom 17-102	102
AOS-6	AOS X-PRI Gigabit	500	Nikon Nikkor 20mm Fixed	
AOS-7	AOS X-PRI Gigabit	500	Nikon 28mm Fixed	
AOS-8	AOS S-VIT 1531	500	Fujinon 50mm Fixed	
GP-1	GoPro Hero 3	120		
GP-2	GoPro Hero 3	120		
GP-3	GoPro Hero 3+	120		
GP-4	GoPro Hero 3+	240		
JVC-2	JVC – GZ-MG27u (Everio)	29.97		
JVC-3	JVC – GZ-MG27u (Everio)	29.97		
JVC-4	JVC – GZ-MG27u (Everio)	29.97		

Figure 40. Camera Locations, Speeds, and Lens Settings, Test No. SFH-1

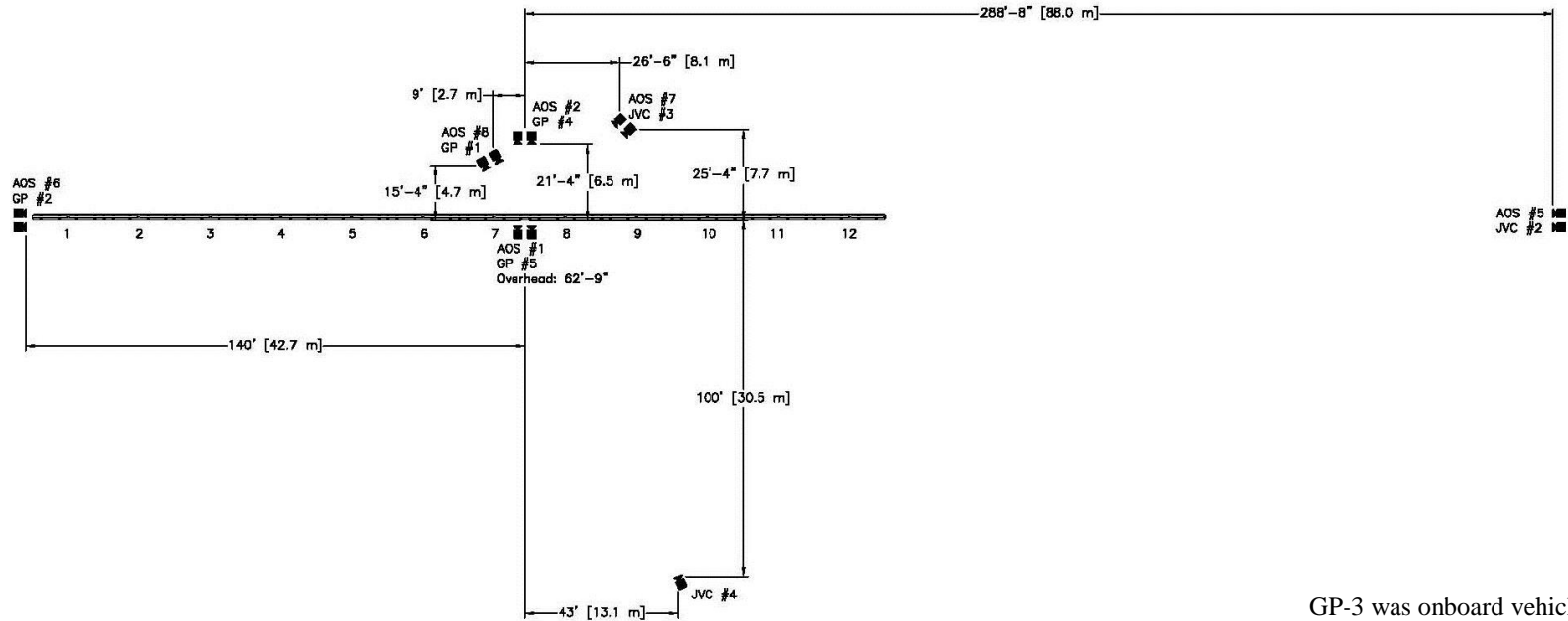

GP-3 was onboard vehicle

No.	Type	Operating Speed (frames/sec)	Lens	Lens Setting
AOS-1	Vitcam CTM	500	Cosmicar 12.5mm Fixed	
AOS-2	AOS Vitcam CTM	500	Nikkor 20mm Fixed	
AOS-5	AOS X-PRI Gigabit	500	Canon TV Zoom 17-102	102
AOS-6	AOS X-PRI Gigabit	500	Fujinon 50mm Fixed	
AOS-7	AOS X-PRI Gigabit	500	Sigma Zoom 28-70	28
AOS-8	AOS S-VIT 1531	500	Sigma UC Zoom 28-70	70
GP-1	GoPro Hero 3	120		
GP-2	GoPro Hero 3	120		
GP-3	GoPro Hero 3+	120		
GP-4	GoPro Hero 3+	120		
GP-5	GoPro Hero 3+	120		
JVC-2	JVC – GZ-MG27u (Everio)	29.97		
JVC-3	JVC – GZ-MG27u (Everio)	29.97		
JVC-4	JVC – GZ-MG27u (Everio)	29.97		

Figure 41. Camera Locations, Speeds, and Lens Settings, Test No. SFH-2

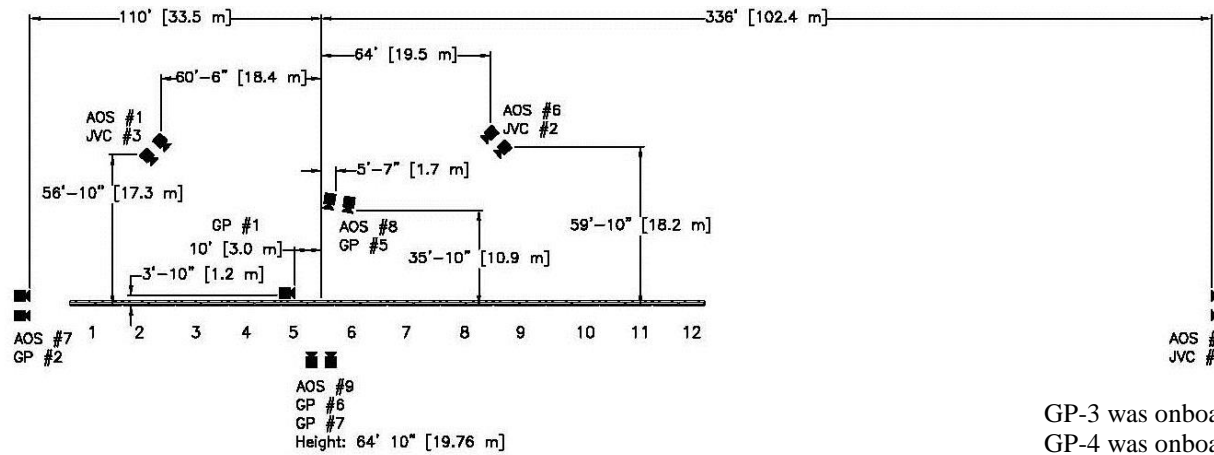

GP-3 was onboard cab
 GP-4 was onboard cargo box

No.	Type	Operating Speed (frames/sec)	Lens	Lens Setting
AOS-1	AOS Vitcam CTM	500	Nikkor 28mm Fixed	
AOS-5	AOS X-PRI Gigabit	500	Vivitar 135mm Fixed	
AOS-6	AOS X-PRI Gigabit	500	Nikon 20mm Fixed	
AOS-7	AOS X-PRI Gigabit	500	Sigma 28-70	28
AOS-8	AOS S-VIT 1531	500	Sigma 28-70	70
AOS-9	AOS TRI-VIT 2236	500	Kowa 12.5mm Fixed	
GP-1	GoPro Hero 3	120		
GP-2	GoPro Hero 3	120		
GP-3	GoPro Hero 3+	120		
GP-4	GoPro Hero 3+	120		
GP-5	GoPro Hero 3+	120		
GP-6	GoPro Hero 3+	120		
GP-7	GoPro Hero 4	240		
JVC-2	JVC – GZ-MG27u (Everio)	29.97		
JVC-3	JVC – GZ-MG27u (Everio)	29.97		
JVC-4	JVC – GZ-MG27u (Everio)	29.97		

Figure 42. Camera Locations, Speeds, and Lens Settings, Test No. SFH-3

5 FULL-SCALE CRASH TEST NO. SFH-1

5.1 Test No. SFH-1

The 5,021-lb (2,277-kg) pickup truck impacted the RESTORE barrier at a speed of 63.4 mph (102.1 km/h) and an angle of 24.8 degrees. A summary of the test results and sequential photographs are shown in Figure 43. Additional sequential photographs are shown in Figures 44 through 47. Documentary photographs of the crash test are shown in Figures 48 and 49.

5.2 Weather Conditions

Test no. SFH-1 was conducted on July 2, 2014 at approximately 2:15 p.m. The weather conditions, as per the National Oceanic and Atmospheric Administration (station 14939/LNK), were reported and are shown in Table 3.

Table 3. Weather Conditions, Test No. SFH-1

Temperature	69° F
Humidity	48%
Wind Speed	15 mph
Wind Direction	34° from True North
Sky Conditions	Overcast
Visibility	10 Statute Miles
Pavement Surface	Dry
Previous 3-Day Precipitation	0.0 in.
Previous 7-Day Precipitation	0.9 in.

5.3 Test Description

Initial vehicle impact was to occur 4.3 ft (1.3 m) upstream from the joint between barrier nos. 5 and 6, as shown in Figure 50, which was selected based on recommendations for rigid barrier tests in MASH and verified through LS-DYNA simulation [3]. The actual point of impact was $41\frac{3}{16}$ in. (1,046 mm) upstream from the joint between barrier nos. 5 and 6. A sequential description of the impact events is contained in

Table 4. The vehicle came to rest 158 ft - 3 in. (48.2 m) downstream from the original impact point and laterally 7 ft - 5 in. (2.3 m) in front of the barrier. The vehicle trajectory and final position are shown in Figures 43 and 51.

Table 4. Sequential Description of Impact Events, Test No. SFH-1

TIME (sec)	EVENT
0.000	The vehicle's left-front bumper contacted barrier no. 5 and began to deform.
0.014	Downstream post under barrier no. 5 began to deflect backward.
0.016	Barrier no. 5 began to twist downstream. Upstream post under barrier no. 6 began to deflect backward.
0.020	Downstream skid under barrier no. 5 began to deflect backward.
0.022	Upstream skid under barrier no. 6 began to deflect backward. Barrier no. 4 starts to deflect backward.
0.034	The roof and left-front door began to deform. Left-front bumper contacts the ACJ between barrier nos. 5 and 6.
0.079	Backside of barrier no. 5 began to crack above ACJ bolt holes. A crack began to form on impact side of barrier no. 5 located behind ACJ.
0.096	The cracks from impact side and non-impact side met at middle of barrier, located along downstream edge of barrier no. 5.
0.106	Skids under barrier no. 5 stopped displacing backward and barrier started to rotate. Barrier no. 7 began to deflect backward.
0.160	The upstream end of concrete beam no. 6 reached maximum deflection.
0.162	The upper tube assembly at upstream end of barrier no. 6 reached maximum deflection.
0.206	Vehicle was parallel to barrier when front of vehicle was approximately 6.5 ft (2.0 m) downstream from ACJ between barrier nos. 6 and 7.
0.220	Barrier no. 8 began to deflect backward.
0.464	Barrier no. 6 returned to the pre-impact position.
0.476	Barrier no. 5 returned to the pre-impact position.
0.540	Vehicle exited system along barrier no. 6.
3.965	Vehicle came to rest 158 ft-3 in. (48.2 m) downstream from impact with front of vehicle yawing towards barrier.

5.4 Barrier Damage

Damage to the barrier was minimal, as shown in Figures 52 and 53. Barrier damage consisted of contact marks, concrete spalling and gouges, and hairline concrete cracks. The

length of vehicle contact along the barrier was approximately 15 ft – ¼ in. (4.6 m), which spanned from 56½ in. (1,435 mm) upstream from the downstream edge of barrier no. 5 to 4 in. (102 mm) downstream from the mid-span of barrier no. 6. Gouging extended from the impact point through the end of the concrete beam along the bottom of the front face of barrier no. 5. Gouging was found along the height of barrier no. 6 located around the upstream splice on the front face. Further gouging was found along the bottom of the front face of barrier no. 6 extending 80 in. (2,032 mm) downstream from the upstream joint. Spalling occurred between barrier nos. 5 and 6 located between the front and back ACJ splices. There were hairline fractures on the back face of barrier no. 6 extending downstream from the bottom splice bolt hole approximately 5 in. (127 mm), as well as underneath the barrier beginning at the center of the upstream end of barrier no. 6 and extending downstream to the hexagonal hole. The first two posts downstream from the splice between barrier nos. 5 and 6 had contact marks along the front face and part of the upstream face.

Multiple skids shifted during impact but returned to their original places. Contact marks along the upper tube assembly started 17 in. (432 mm) downstream from the impact point and extended 110 in. (2,794 mm) downstream.

Permanent set was estimated to be ⅞ in. (22 mm). However, permanent set was not measured in the field until after the impacted joint had been dis-assembled to remove the transducers. The maximum lateral dynamic barrier deflection at the top upstream end of concrete barrier no. 6 and the top of the upper tube assembly at the same location, including barrier rotation backward, were 11.2 in. (284 mm) and 10.9 in. (277 mm), respectively, as determined from high-speed digital video analysis. Other barrier deflections at different locations at the time of maximum deflection are shown in Table 5. The working width of the system was found to be 33.5 in. (851 mm), also determined from high-speed digital video analysis.

Table 5. Barrier Deflections at Maximum Deflection Times, Test No. SFH-1

Location At Time	Deflections in. (mm)	
	Concrete Beam	Upper Tube
	0.160 sec	0.162 sec
Upstream Barrier No. 5	3.7 (94)	5.1 (130)
Middle Barrier No. 5	7.4 (188)	8.0 (203)
Downstream Barrier No. 5	10.9 (277)	10.8 (274)
Upstream Barrier No. 6	11.2 (284)	10.9 (277)
Middle Barrier No. 6	7.8 (198)	8.5 (216)
Downstream Barrier No. 6	6.2 (157)	6.0 (152)

5.5 Vehicle Damage

The damage to the vehicle was moderate, as shown in Figures 54 and 55. The maximum occupant compartment deformations are listed in Table 6 along with the deformation limits established in MASH for various areas of the occupant compartment. Note that none of the MASH-established deformation limits were violated. Complete occupant compartment and vehicle deformations and the corresponding locations are provided in Appendix C.

Table 6. Maximum Occupant Compartment Deformations by Location, Test No. SFH-1

LOCATION	MAXIMUM DEFORMATION in. (mm)	MASH ALLOWABLE DEFORMATION in. (mm)
Wheel Well & Toepan	½ (13)	≤ 9 (229)
Floorpan & Transmission Tunnel	½ (13)	≤ 12 (305)
Side Front Panel (in Front of A-Pillar)	½ (13)	≤ 12 (305)
Side Door (Above Seat)	½ (13)	≤ 9 (229)
Side Door (Below Seat)	1 (25)	≤ 12 (305)
Roof	0 (0)	≤ 4 (102)
Windshield	0 (0)	≤ 3 (76)

The majority of the damage was concentrated on the left-front corner and left side of the vehicle where the impact occurred. A 3-in. (76-mm) buckle was found in the center of the front bumper surrounded by 3 in. (76 mm) of scraping. A kink was located in the bottom of the front bumper, located 5 in. (127 mm) left of center. Both the left and right fog lights were disengaged. The left headlight was disengaged. The left-front bumper had an 8-in. (203-mm) vertical tear. The left-front bumper was deformed inward below the light fixture.

The left-front control arm disengaged. The left-front tire deflated and released from the rim. The left-front tire rim had scraping along the edge, and the outer hub cap folded 6 in. (152 mm). Multiple tears were found on the left-front tire, including in the tire's treads.

The entire left side of the vehicle had scrapes. Multiple dents were found on the left-front door and left-rear door. A 2¼-in. (57-mm) gap was found between the hood and the left fender. The left-front fender was crushed laterally inward approximately 6 in. (152 mm). A 45-in. (1,143-mm) long dent was found in the top of the left fender below the hood. The front of the left-front door was ajar 1 in. (25 mm), while the back of the left-front door overlapped the left-rear door ½ in. (13 mm). The left-rear door was ajar 1 in. (25 mm). The left tail-light separated 1½ in. (38 mm) due to the rear end of the vehicle contacting the top corner of the concrete beam. The left-rear tire deflated with a 1½-in. (38-mm) long tear from contact with the bolts underneath the beam. The outer edge of the left-rear rim was gouged and scraped. A vertical buckle was found on the rear bumper that was 8½ in. (216 mm) tall, located 19 in. (483 mm) left of center. The damage on the right side of the vehicle was present prior to test no. SFH-1.

5.6 Occupant Risk

The calculated occupant impact velocities (OIVs) and maximum 0.010-sec occupant ridedown accelerations (ORAs) in both the longitudinal and lateral directions are shown in Table 7. Note that the OIVs and ORAs were within the suggested limits provided in MASH. The

calculated THIV, PHD, and ASI values are also shown in Table 7. The results of the occupant risk analysis, as determined from the accelerometer data, are summarized in Figure 43. The recorded data from the accelerometers and the rate transducers are shown graphically in Appendix D. The two accelerometers used during test no. SFH-1 recorded slightly different traces, which could have been contributed to by the location of the accelerometers with respect to the center of gravity, the orientation of the accelerometers compared to each other, or the different sensors in each different unit. While the acceleration traces were very similar, the slight differences in t^* created different values for the OIV and ORA values. Note, the SLICE-1 unit was designated as the primary unit during this test as it was mounted closer to the c.g. of the vehicle.

Table 7. Summary of OIV, ORA, THIV, PHD, and ASI Values, Test No. SFH-1

Evaluation Criteria		Transducer		MASH Limits
		SLICE-1 (Primary)	SLICE-2	
OIV ft/s (m/s)	Longitudinal	-17.62 (-5.37)	-16.04 (-4.89)	≤ 40 (12.2)
	Lateral	21.29 (6.49)	21.16 (6.45)	≤40 (12.2)
ORA g's	Longitudinal	-4.81	-9.62	≤ 20.49
	Lateral	8.40	10.10	≤ 20.49
MAX. ANGULAR DISPL. deg.	Roll	-27.3	-24.2	≤75
	Pitch	-8.0	-9.0	≤75
	Yaw	36.4	35.7	not required
THIV ft/s (m/s)		25.89 (7.89)	25.72 (7.84)	not required
PHD g's		9.39	13.86	not required
ASI		1.24	1.31	not required

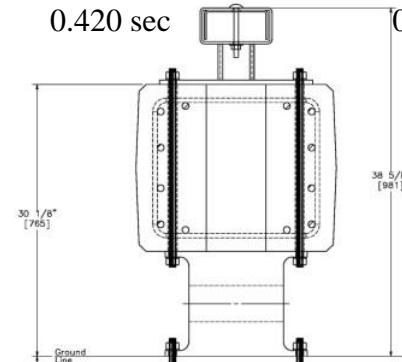
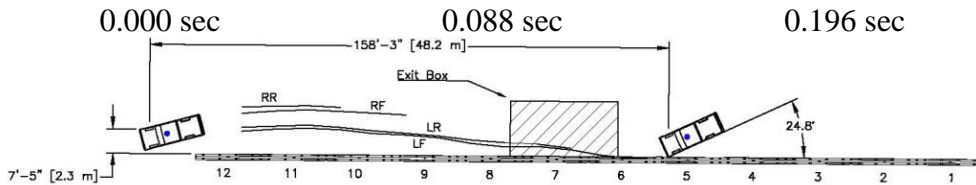

- Test AgencyMwRSF
- Test Number..... SFH-1
- Date7/2/2014
- MASH Test Designation4-11
- Test Article.....Low-Maintenance, Energy-Absorbing Concrete Median Barrier
- Total Length239 ft 11½ in. (73.1 m)
- Key Component – Concrete Barrier Section
 - Length239½ in. (6,083 mm)
 - Height18½ in. (470 mm)
 - Depth21½ in. (546 mm)
- Key Component – Post
 - Nominal Height11½ in. (295 mm)
 - Width10 in. (254 mm)
 - Depth15¾ in. (400 mm)
 - Spacing60 in. (1,524 mm)
- Vehicle Make /Model.....2005 Dodge Ram 1500
 - Curb Weight5,094 lb (2,311 kg)
 - Test Inertial Weight5,021 lb (2,277 kg)
 - Gross Static Weight5,186 lb (2,352 kg)
- Impact Conditions
 - Speed63.4 mph (102.1 km/h)
 - Angle24.8 deg
 - Impact Location.....41³/₁₆ in. (1,046 mm) upstream from joint between barrier nos. 5 and 6
- Exit Conditions
 - Speed46.2 mph (74.4 km/h)
 - Angle8.4 deg
- Exit Box CriterionPass
- Vehicle Stability.....Satisfactory
- Vehicle Stopping Distance158 ft – 3 in. (48.2 m) downstream of impact
Laterally 7 ft – 5 in. (2.3 m) in front of the system
- Vehicle Damage.....Moderate
 - VDS [11]11-LFQ-3
 - CDC [12].....11-LFMW-6
 - Maximum Interior Deformation1 in. (25 mm)

- Test Article DamageMinimal
- Maximum Test Article Deflections
 - Permanent Set7/8 in. (22 mm)
 - Dynamic of Concrete Beam11.2 in. (284 mm)
 - Dynamic of Upper Tube Assembly10.9 in. (277mm)
 - Working Width.....33.5 in. (851 mm)
- Impact Severity (IS).....118.6 kip-ft (160.8 kJ) > 105.6 kip-ft (143.2 kJ) limit from MASH

• Transducer Data

Evaluation Criteria		Transducer		MASH Limit
		SLICE-1 (Primary)	SLICE-2	
OIV ft/s (m/s)	Longitudinal	-17.62 (-5.37)	-16.04 (-4.89)	≤ 40 (12.2)
	Lateral	21.29 (6.49)	21.16 (6.45)	≤ 40 (12.2)
ORA g's	Longitudinal	-4.81	-9.62	≤ 20.49
	Lateral	8.40	10.10	≤ 20.49
MAX ANGULAR DISP. deg.	Roll	-27.3	-24.2	≤ 75
	Pitch	-8.0	-9.0	≤ 75
	Yaw	36.4	35.7	not required
THIV – ft/s (m/s)		25.89 (7.89)	25.72 (7.84)	not required
PHD – g's		9.39	13.86	not required
ASI		1.24	1.31	not required

96

Figure 43. Summary of Test Results and Sequential Photographs, Test No. SFH-1



0.000 sec



0.036 sec



0.148 sec



0.276 sec



0.464 sec



2.896 sec



0.000 sec



0.048 sec



0.088 sec



0.154 sec



0.196 sec



0.276 sec

Figure 44. Additional Sequential Photographs, Test No. SFH-1



0.000 sec



0.824 sec



0.048 sec



1.220 sec



0.174 sec



1.146 sec



0.290 sec



1.830 sec



0.528 sec



2.986 sec

Figure 45. Additional Sequential Photographs, Test No. SFH-1

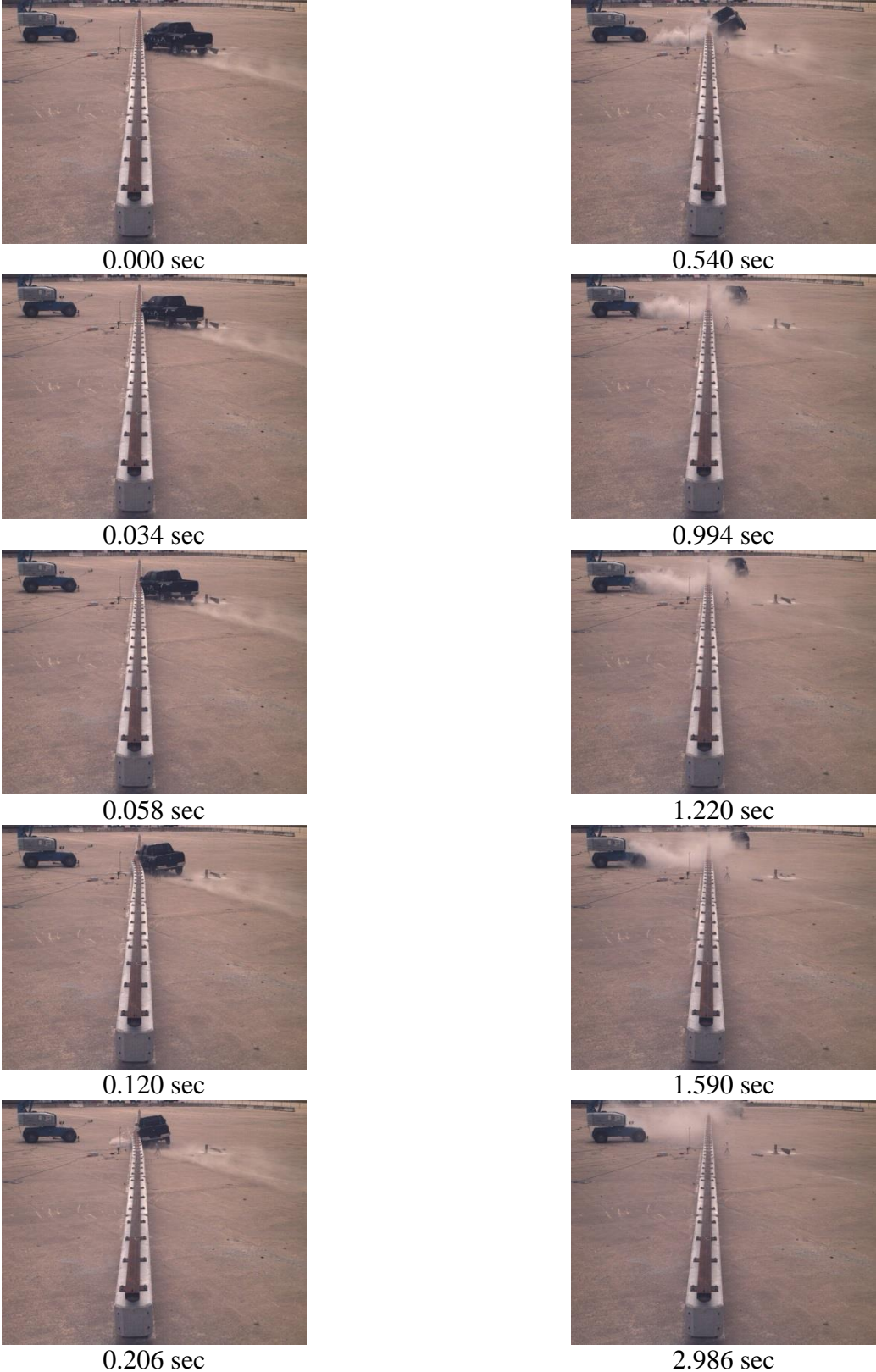

Figure 46. Additional Sequential Photographs, Test No. SFH-1



0.000 sec



0.178 sec



0.048 sec



0.220 sec

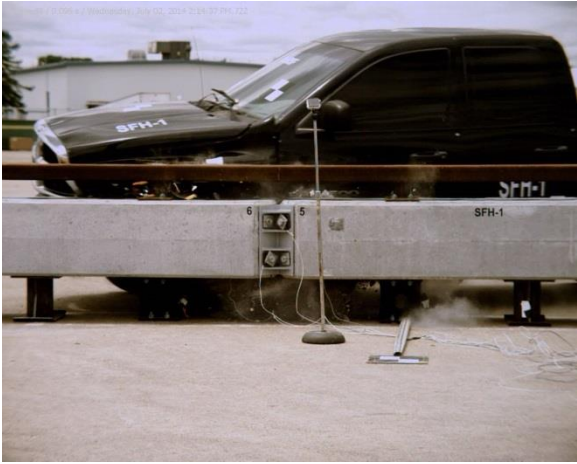

0.088 sec



0.476 sec

Figure 47. Additional Sequential Photographs, Test No. SFH-1



Figure 48. Documentary Photographs, Test No. SFH-1



Figure 49. Documentary Photographs, Test No. SFH-1

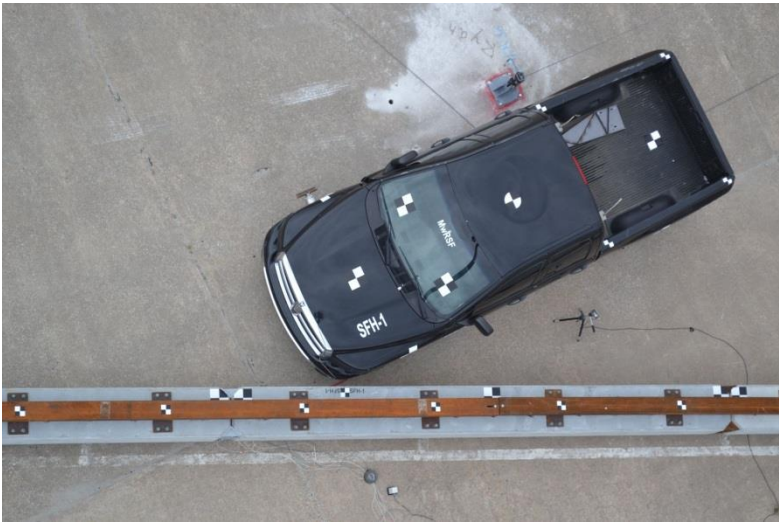

Figure 50. Impact Location, Test No. SFH-1



Figure 51. Vehicle Final Position and Trajectory Marks, Test No. SFH-1



Front Face



Back Face



Back Face Underneath

Figure 52. System Damage, Barrier Nos. 5 and 6, Test No. SFH-1



First Post Downstream from Barrier Nos. 5 and 6 Joint



First Skid and Second Post Downstream from Barrier Nos. 5 and 6 Joint

Figure 53. System Damage, Post Contact Marks Under Barrier No. 6, Test No. SFH-1



Figure 54. Vehicle Damage, Left Side, Test No. SFH-1



Figure 55. Vehicle Damage, Left-Front and Left-Rear Tires, Test No. SFH-1

5.7 2270P Comparison to Rigid Barrier Tests

Rigid vertical-faced concrete barriers were desired for comparison with the RESTORE barrier as they would likely produce the largest vehicle accelerations. However, crash test data was not available, so other rigid barrier crash tests were utilized.

The longitudinal and lateral vehicle accelerations, as measured at the vehicle's c.g., were also processed using a 50-msec moving average. The 50-msec moving average vehicle accelerations were then combined with the uncoupled yaw angle versus time data in order to estimate the vehicular loading applied to the barrier system. From the data analysis, the perpendicular impact force was determined for the RESTORE barrier, as shown in Figure 56. The maximum perpendicular, or lateral, load imparted to the barrier was 58 kips (258 kN) and 62 kips (276 kN), as determined by the SLICE-1 and SLICE-2, respectively.

The results of test no. SFH-1 were compared to the results of two different MASH test designation no. 4-11 crash tests, test no. 420020-3 with a 2270P pickup truck impacting a single-slope barrier attached to a bridge deck [13] and test no. KSFRP-1 with a 2270P pickup truck impacting a vertical barrier attached to a fiber-reinforced polymer (FRP) deck [14]. The comparison tests and the force comparison plots for the 2270P vehicle are shown in Table 8 and Figure 57, respectively. The lateral barrier force was calculated in test nos. 420020-3 and KSFRP-1 using the same procedure as in test no. SFH-1's barrier force calculations. The peak lateral barrier forces were 33 to 38 percent less than those observed in the single-slope barrier impact and 17 to 23 percent less than those observed in the vertical barrier on FRP deck impact. The peak lateral acceleration was reduced by up to 47 percent and 25 percent when comparing test no. SFH-1 to test nos. 420020-3 and KSFRP-1, respectively. The lateral and longitudinal acceleration comparisons are shown in Figures 58 and 59, respectively. For test no. KSFRP-1, note that the barrier and FRP bridge deck deflected some during the impact event.

The lateral OIV showed similar results to the peak lateral accelerations. When compared to both test nos. 420020-3 and KSFRP-1, the lateral OIV was reduced by up to 29 percent. Similarly, the longitudinal OIV was reduced by up to 27 percent when compared to test nos. 420020-3 and KSFRP-1. The lateral ORA was reduced when compared to test no. 420020-3, but it increased when compared to test no. KSFRP-1. The lateral ORA in test no. KSFRP-1 may be lower than a rigid barrier, since the barrier on the FRP deck deflected. The longitudinal ORA did not change significantly.

Table 8. Test and Force Comparisons, 2270P Vehicle

Test Agency	TTI	MwRSF	MWRSF	MWRSF
Description	Single Slope	Vertical on FRP	RESTORE Barrier	
Test No.	420020-3	KSFRP-1	SFH-1 SLICE-1 (Primary)	SFH-1 SLICE-2
Reference	11	14	-	-
Vehicle	2270P	2270P	2270P	2270P
Test Inertial Weight lb (kg)	5,036 (2,284)	5,009 (2,272)	5,021 (2,277)	5,021 (2,277)
Impact Velocity mph (km/h)	63.8 (102.7)	61.1 (98.3)	63.4 (102.1)	63.4 (102.1)
Impact Angle degrees	24.8	25.9	25.4	25.4
IS kip-ft (kJ)	120.6 (163.5)	119.3 (161.7)	118.5 (160.7)	118.5 (160.7)
Lateral OIV ft/s (m/s)	-29.82 (-9.09)	-25.23 (-7.69)	21.29 (6.49)	21.16 (6.45)
Longitudinal OIV ft/s (m/s)	-21.98 (-6.70)	17.88 (-5.45)	-17.62 (-5.37)	-16.04 (-4.89)
Lateral ORA (g's)	-11.72	-6.34	8.40	10.10
Longitudinal ORA (g's)	-5.26	6.51	-4.81	-9.62
CFC 180 (10 msec Ave) Peak Lateral Acceleration (g's)	28.1	19.7	15.8	14.8
Peak Barrier Force kips (kN)	93 (414)	75 (334)	58 (258)	62 (276)
Dynamic Deflection in. (mm)	0 (0)	4.4 (112)	11.2 (284)	11.2 (284)

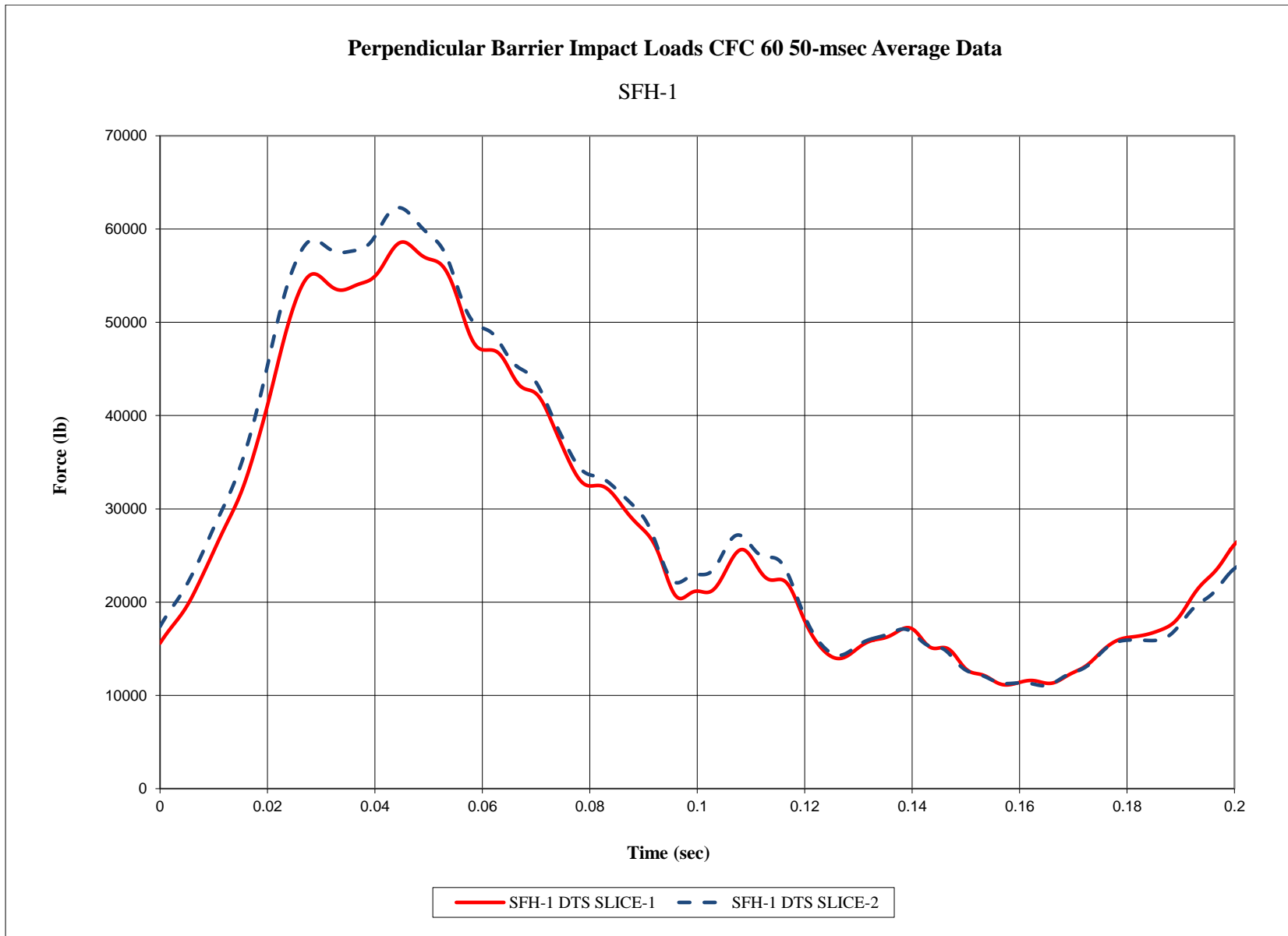

Figure 56. Perpendicular Impact Forces Imparted to the Barrier System, Test No. SFH-1

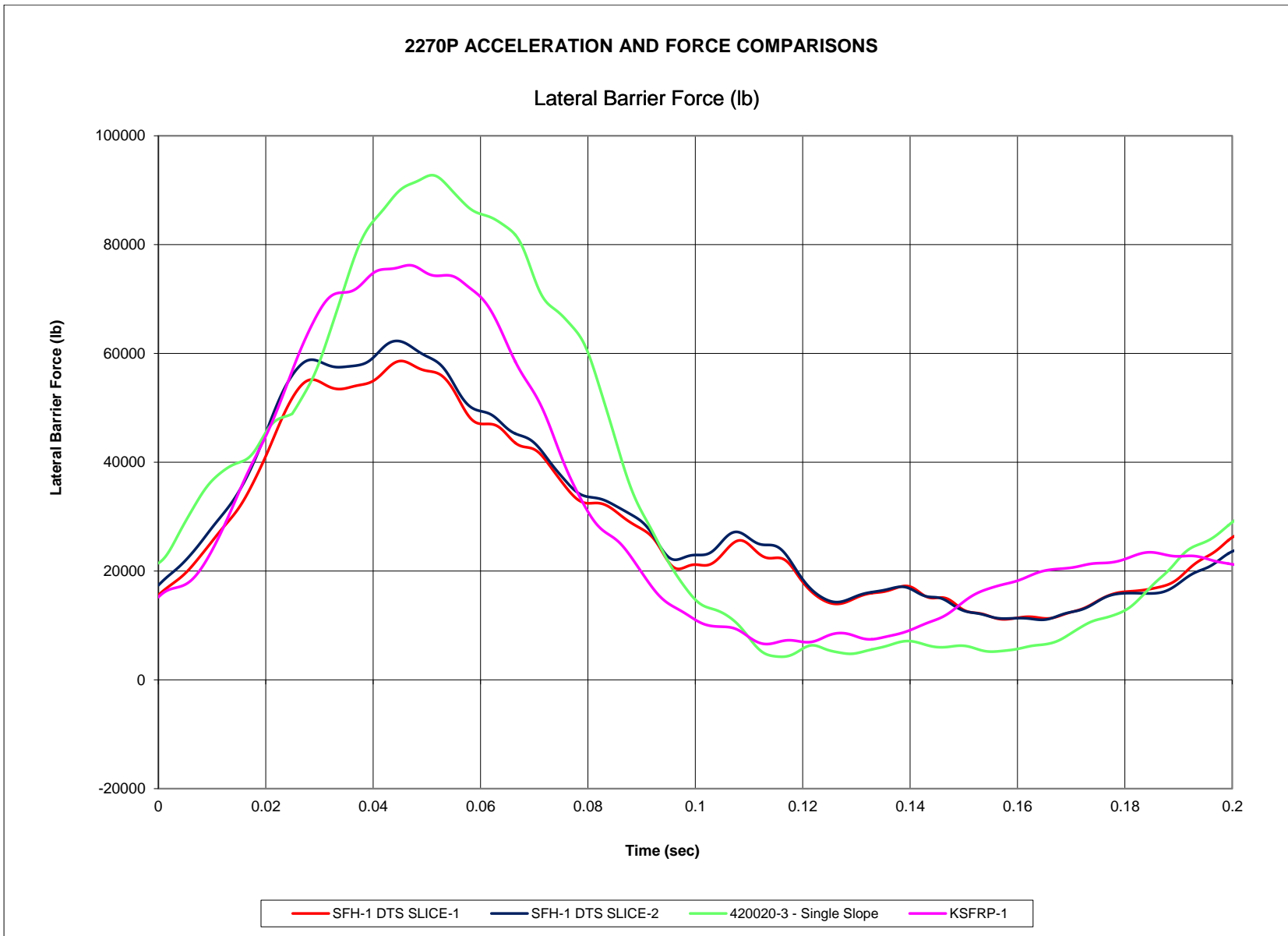

Figure 57. Force Comparisons, 2270P Vehicle

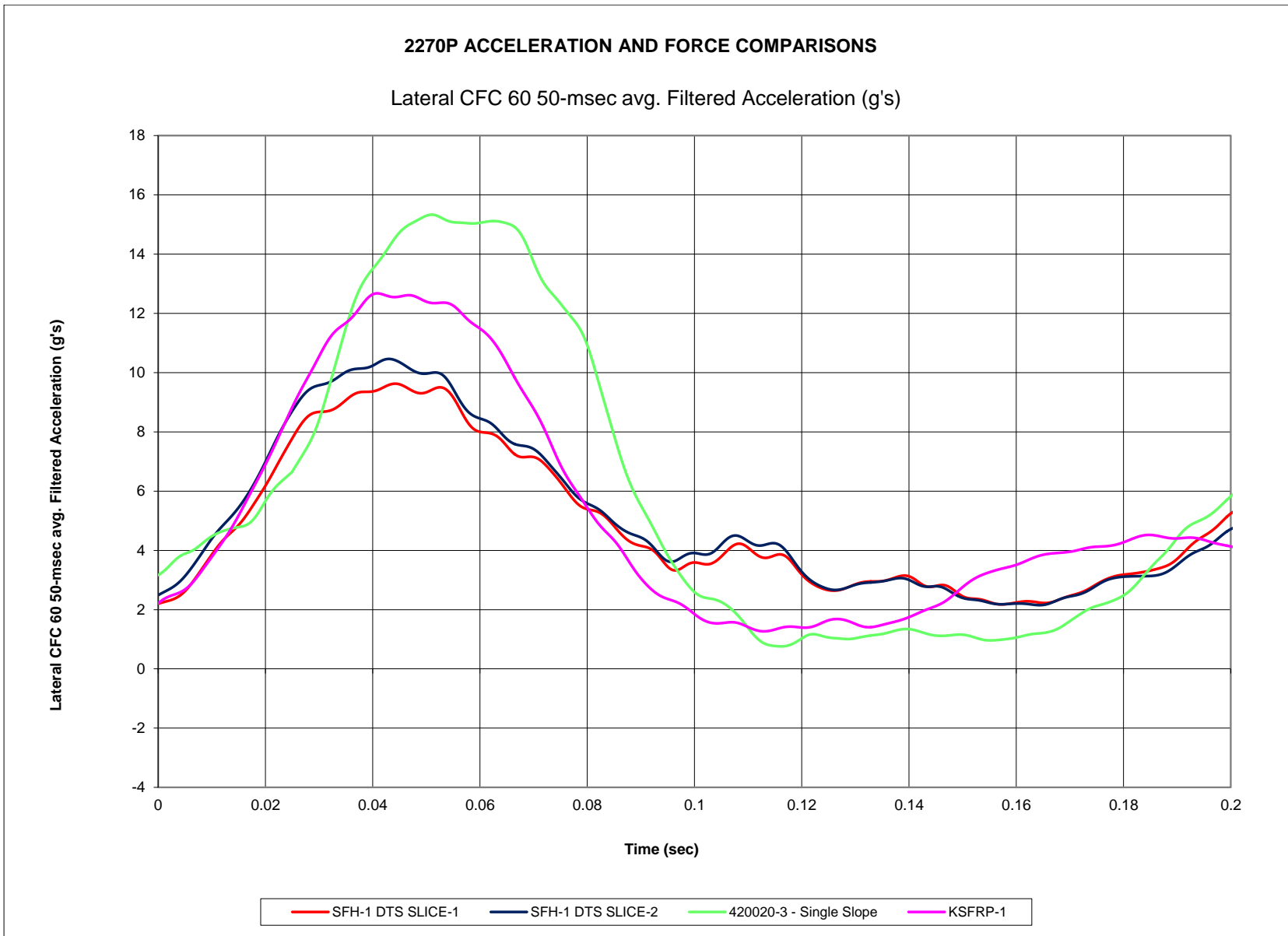

Figure 58. Lateral Acceleration Comparison, 2270P Vehicles

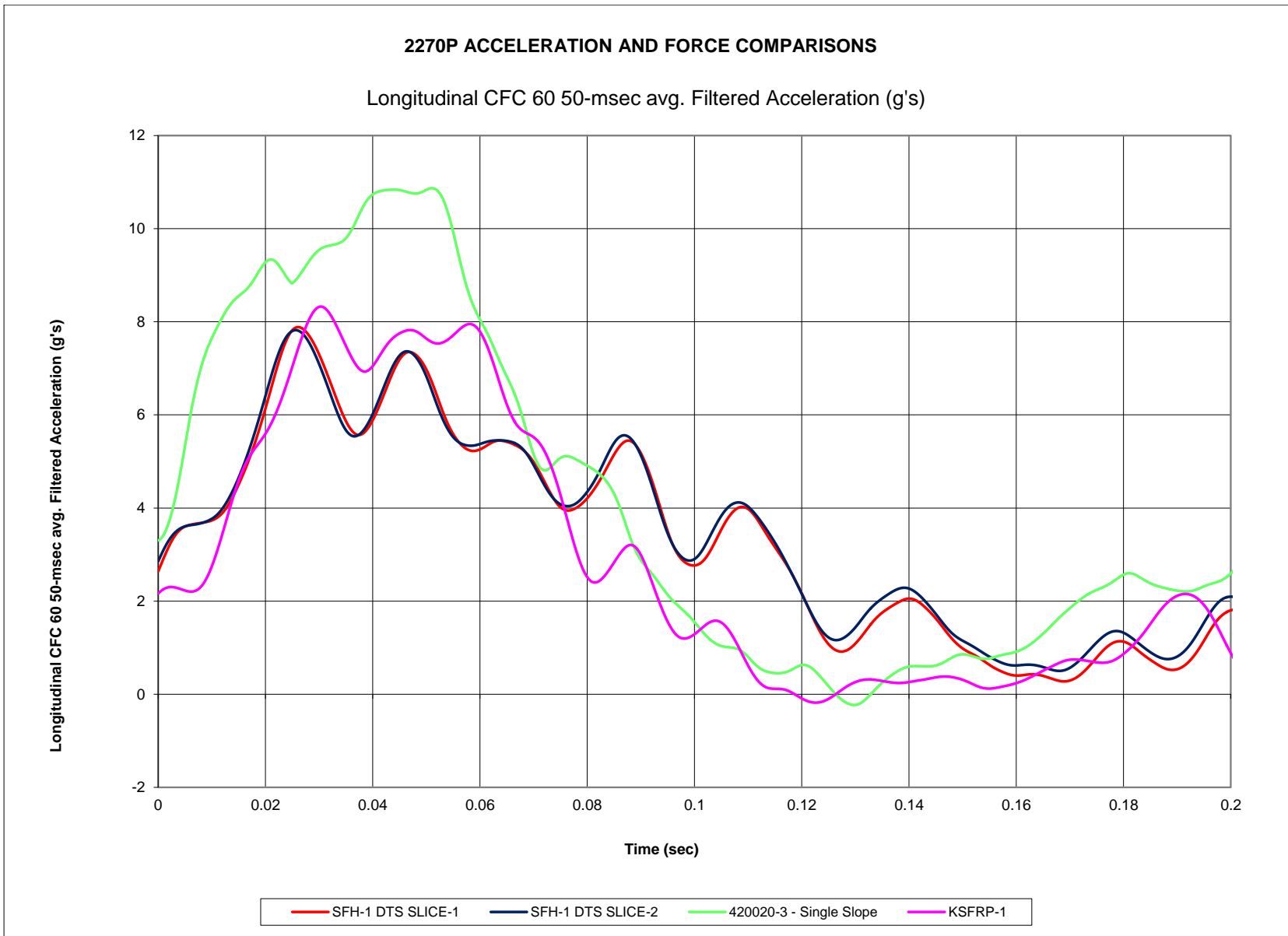

Figure 59. Longitudinal Acceleration Comparison, 2270P Vehicles

5.8 Discussion

The analysis of the test results for test no. SFH-1 showed that the RESTORE barrier adequately contained and redirected the 2270P vehicle with controlled lateral displacements of the barrier. There were no detached elements or fragments which showed potential for penetrating the occupant compartment or presenting undue hazard to other traffic. Deformations of, or intrusions into, the occupant compartment that could have caused serious injury did not occur. The test vehicle did not penetrate or ride over the barrier and remained upright during and after the collision. Vehicle roll, pitch, and yaw angular displacements, as shown in Appendix D, were deemed acceptable, because they did not adversely influence occupant risk safety criteria or cause rollover. After impact, the vehicle exited the barrier at an angle of 8.3 degrees, and its trajectory did not violate the bounds of the exit box. Therefore, test no. SFH-1, conducted on the energy-absorbing concrete median barrier, was determined to be acceptable according to the MASH safety performance criteria for test designation no. 4-11.

6 FULL-SCALE CRASH TEST NO. SFH-2

6.1 Test No. SFH-2

The 2,406-lb (1,091-kg) small car impacted the RESTORE barrier at a speed of 64.3 mph (103.5 km/h) and an angle of 24.8 degrees. A summary of the test results and sequential photographs are shown in Figure 60. Additional sequential photographs are shown in Figures 61 through 63. Documentary photographs of the crash test are shown in Figures 64 through 66.

6.2 Weather Conditions

Test no. SFH-2 was conducted on August 11, 2014 at approximately 1:00 p.m. The weather conditions, as per the National Oceanic and Atmospheric Administration (station 14939/LNK), were reported and are shown in Table 9.

Table 9. Weather Conditions, Test No. SFH-2

Temperature	77° F
Humidity	43%
Wind Speed	21 mph
Wind Direction	35° from True North
Sky Conditions	Sunny
Visibility	10 Statute Miles
Pavement Surface	Dry
Previous 3-Day Precipitation	0.63 in.
Previous 7-Day Precipitation	0.84 in.

6.3 Test Description

Initial vehicle impact was to occur 3.6 ft (1.1 m) upstream of the first post downstream of the joint between barrier nos. 7 and 8, as shown in Figure 67. This location was selected based on the recommendation for rigid barrier tests in MASH and verified through LS-DYNA simulation. The impact point was downstream from test no. SFH-1 so damage could be distinguished between the two tests. The actual point of impact was $8\frac{5}{16}$ in. (211 mm) upstream

of the joint between barrier nos. 7 and 8. A sequential description of the impact events is contained in Table 10. The vehicle came to rest 167 ft (50.9 m) downstream from the original impact point and 14 ft – 2 in. (4.3 m) laterally behind the system. The vehicle trajectory and final position are shown in Figures 60 and 68.

Table 10. Sequential Description of Impact Events, Test No. SFH-2

TIME (sec)	EVENT
0.000	The left-front bumper began to deform as it contacted barrier no. 7 and began to deflect backward.
0.012	The left-front bumper contacted traffic-side, angled-joint bracket between barrier nos. 7 and 8.
0.016	Upstream rubber post of barrier no. 8 began to deflect backward.
0.022	Upstream skid of barrier no. 8 began to deflect backward.
0.092	The left-front window shattered when the dummy head contacted the window. The left-front tire contacted the first post downstream of joint between barrier nos. 7 and 8.
0.128	The left-front tire contacted the second post downstream of joint between barrier nos. 7 and 8.
0.142	The barrier reached maximum deflection.
0.150	Barrier no. 7 began to return to its original position.
0.178	Downstream skid of barrier no. 7 began to deflect forward.
0.250	The vehicle was parallel to system with front of vehicle located approximately 10 in. (254 mm) upstream of joint between barrier nos. 8 and 9.
0.330	Vehicle lost contact with system along barrier no. 8. Barrier no. 6 returned to pre-impact position.
1.130	Vehicle contacted system again along barrier no. 11.
4.276	Vehicle came to rest 167 ft (50.9 m) downstream from original impact point and 14 ft – 2 in. (4.3 m) behind end of system.

6.4 Barrier Damage

Damage to the barrier was minimal, as shown in Figures 69 through 72. Barrier damage consisted of gouging and contact marks on the front face of the concrete segments and cuts in the rubber posts. The length of the vehicle contact along the barrier was approximately 12 ft – 7 in. (3.8 m), which spanned from 27 in. (686 mm) upstream of the joint between barrier nos. 7 and 8

to 27 in. (686 mm) downstream from the mid-span of barrier no. 8. The vehicle re-contacted the system after exiting the system initially. This contact length was approximately 30 ft – 4 in. (9.2 m), which spanned from 10 ft - 4 in. (3.1 m) upstream from the downstream end of barrier no. 11 and extended through the end of the system.

Gouging was present on the bottom of barrier no. 7 along the last 20 in. (508 mm) of the barrier at the downstream end. The gouging continued on the bottom of barrier no. 8 for 39 in. (991 mm). Tire contact marks were found on the upstream face of the first post downstream from the joint between barrier nos. 7 and 8 that were 3½ in. (89 mm) wide x 7 in. (178 mm) tall. From contact with the vehicle's rim, this same post was cut along the length of the front face 3 in. (76 mm) above the groundline that had a maximum depth of ½ in. (13 mm). The second post downstream from the joint between barrier nos. 7 and 8 was cut along the length of the front face located 4 in. (102 mm) above the groundline to a maximum depth of 2 in. (51 mm). The upstream corner of the front face had contact marks 5¼ in. (133 mm) wide x 7 in. (178 mm) tall. Contact marks were present on the upstream corner of the front face along the upper tube assembly post located just downstream from the joint between barrier nos. 7 and 8. From the second impact, the bottom of barrier no. 11 had gouges starting 93 in. (2,362 mm) upstream from the downstream end of barrier no. 11 that continued for 28 in. (711 mm).

The permanent set of the barrier was approximately 1¾ in. (44 mm), which was measured at the joint between barrier nos. 7 and 8. The maximum lateral dynamic barrier deflection at the top downstream end barrier no. 7 and the top of the upper tube assembly at the same location, including barrier rotation backward, were 7.1 in. (180 mm) and 7.3 in. (185 mm), respectively, as determined from high-speed digital video analysis. Multiple barrier deflections are recorded at the time of the maximum deflection, as shown in Table 11. The working width of

the system was found to be 28.8 in. (732 mm), also determined from high-speed digital video analysis.

Table 11. Barrier Deflections at Maximum Deflection Times, Test No. SFH-2

Location At Time	Deflections in. (mm)	
	Concrete Beam	Upper Tube
	0.142 sec	0.146 sec
Upstream Barrier No. 7	2.7 (69)	3.4 (86)
Middle Barrier No. 7	5.3 (135)	5.4 (137)
Downstream Barrier No. 7	7.1 (180)	7.3 (185)
Upstream Barrier No. 8	6.7 (170)	7.3 (185)
Middle Barrier No. 8	5.1 (130)	5.6 (142)
Downstream Barrier No. 8	2.6 (66)	3.5 (89)

6.5 Vehicle Damage

The damage to the vehicle was moderate, as shown in Figures 73 and 74. The maximum occupant compartment deformations are listed in Table 12 along with the deformation limits established in MASH for various areas of the occupant compartment. Note that none of the MASH-established deformation limits were violated. Complete occupant compartment and vehicle deformations and the corresponding locations are provided in Appendix C.

The majority of the damage was concentrated on the left-front corner and left side of the vehicle where the impact occurred. The front bumper and the left headlight were both disengaged. The hood separated 1 in. (25 mm) near the right headlight compartment. A 5-in. (127-mm) deep x 18-in. (457-mm) long dent was found along the left edge of the hood located 5 in. (127 mm) left of center. The front windshield had cracking through the entire windshield. The left fender had a 20-in. (508-mm) long cut along the top of the fender.

A 6¾-in. (171-mm) cut was found in the left-front door located 9½ in. (241 mm) above the bodyline. The left-front tire was deflated, with gouges around the outer rim. The left fender was crushed inward approximately 6 in. (152 mm). The A-pillar had dents located 5 in. (127 mm) and 11½ in. (292 mm) from the bottom of the pillar. The left-front window shattered from contact with the dummy head. A 2½-in. (64-mm) gap was located between the left-front door and the A-pillar. The top of the B-pillar had a 2-in. (51-mm) dent. Contact marks extended from the left fender through 17 in. (432 mm) back of the center of the left-rear wheel well. The left-front roof had a dent measuring approximately 25 in. (635 mm) x 9 in. (229 mm) x 1 in. (25 mm) deep. The bottom of the left-front door was crushed inward.

Table 12. Maximum Occupant Compartment Deformations by Location, Test No. SFH-2

LOCATION	MAXIMUM DEFORMATION in. (mm)	MASH-ALLOWABLE DEFORMATION in. (mm)
Wheel Well & Toepan	2½ (64)	≤ 9 (229)
Floorpan & Transmission Tunnel	¾ (19)	≤ 12 (305)
Side Front Panel (in Front of A-Pillar)	1½ (38)	≤ 12 (305)
Side Door (Above Seat)	2¾ (70)	≤ 9 (229)
Side Door (Below Seat)	3¼ (83)	≤ 12 (305)
Roof	1¾ (44)	≤ 4 (102)
Windshield	0 (0)	≤ 3 (76)

6.6 Occupant Risk

The calculated occupant impact velocities (OIVs) and maximum 0.010-sec occupant ridedown accelerations (ORAs) in both the longitudinal and lateral directions are shown in Table 13. Note that the OIVs and ORAs were within the suggested limits provided in MASH. The calculated THIV, PHD, and ASI values are also shown in Table 13. The results of the occupant risk analysis, as determined from the accelerometer data, are summarized in Figure 60. The

recorded data from the accelerometers and the rate transducers are shown graphically in Appendix D. The two accelerometers used during test no. SFH-2 recorded slightly different traces, which could have been due to the location of the accelerometers with respect to the center of gravity, the orientation of the accelerometers compared to each other, or the different sensors in each different unit. While the acceleration traces were very similar, the slight differences in t* created different values for the OIV and ORA values.

Table 13. Summary of OIV, ORA, THIV, PHD, and ASI Values, Test No. SFH-2

Evaluation Criteria		Transducer		MASH Limits
		SLICE-1 (Primary)	SLICE-2	
OIV ft/s (m/s)	Longitudinal	-26.51 (-8.08)	-26.31 (-8.02)	≤ 40 (12.2)
	Lateral	25.59 (7.80)	24.38 (7.43)	≤40 (12.2)
ORA g's	Longitudinal	-5.06	-4.86	≤ 20.49
	Lateral	8.19	7.35	≤ 20.49
MAX. ANGULAR DISPL. deg.	Roll	-4.4	3.7	≤75
	Pitch	-4.6	-6.4	≤75
	Yaw	30.6	29.8	not required
THIV ft/s (m/s)		35.20 (10.73)	33.66 (10.26)	not required
PHD g's		8.69	7.99	not required
ASI		2.01	1.92	not required

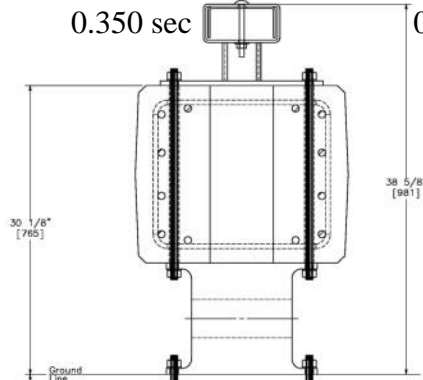
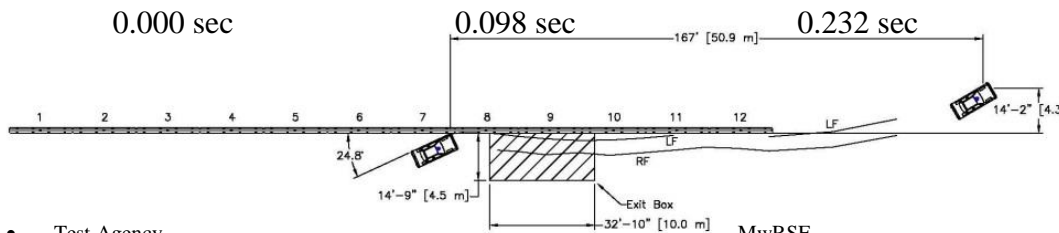

- Test AgencyMwRSF
- Test Number..... SFH-2
- Date 8/11/2014
- MASH Test Designation 4-10
- Test Article..... Low-Maintenance, Energy-Absorbing Concrete Median Barrier
- Total Length 239 ft 11½ in. (73.1 m)
- Key Component – Concrete Barrier Section
 - Length 239½ in. (6,083 mm)
 - Height 18½ in. (470 mm)
 - Depth 21½ in. (546 mm)
- Key Component – Post
 - Height 11½ in. (295 mm)
 - Width 10 in. (254 mm)
 - Depth 15¾ in. (400 mm)
 - Spacing 60 in. (1,524 mm)
- Vehicle Make /Model..... 2005 Kia Rio
 - Curb 2,406 lb (1,091 kg)
 - Test Inertial..... 2,406 lb (1,091 kg)
 - Gross Static..... 2,572 lb (1,167 kg)
- Impact Conditions
 - Speed 64.3 mph (103.5 km/h)
 - Angle 24.8 deg
 - Impact Location..... 8⁵/₁₆ in. (211 mm) upstream of the joint
Between barrier nos. 7 and 8
- Exit Conditions
 - Speed 44.6 mph (71.8 km/h)
 - Angle 4.6 deg
- Exit Box Criterion Pass
- Vehicle Stability Satisfactory
- Vehicle Stopping Distance 167 ft (50.9 m) downstream of impact
..... Laterally 14 ft – 2 in. (4.3 m) behind the system
- Vehicle Damage Moderate
 - VDS [11] 11-LFQ-5
 - CDC [12] 11-LFAW-6
 - Maximum Interior Deformation 3¼ in. (83 mm)

- Impact Severity (IS) 58.3 kip-ft (79.1 kJ) > 51.0 kip-ft (69.1 kJ) limit from MASH
- Test Article Damage Minimal
- Maximum Test Article Deflections
 - Permanent Set 1¾ in. (44 mm)
 - Dynamic of Concrete Beam 7.1 in. (180 mm)
 - Dynamic of Upper Tube Assembly 7.3 in. (185 mm)
 - Working Width..... 28.8 in. (732 mm)
- Transducer Data

Evaluation Criteria		Transducer		MASH Limit
		SLICE-1 (Primary)	SLICE-2	
OIV ft/s (m/s)	Longitudinal	-26.51 (-8.08)	-26.31 (-8.02)	≤ 40 (12.2)
	Lateral	25.59 (7.80)	24.38 (7.43)	≤ 40 (12.2)
ORA g's	Longitudinal	-5.06	-4.86	≤ 20.49
	Lateral	8.19	7.35	≤ 20.49
MAX ANGULAR DISP. deg.	Roll	-4.4	3.7	≤ 75
	Pitch	-4.6	-6.4	≤ 75
	Yaw	30.6	29.8	not required
THIV – ft/s (m/s)		35.20 (10.73)	33.66 (10.26)	not required
PHD – g's		8.69	7.99	not required
ASI		2.01	1.92	not required

Figure 60. Summary of Test Results and Sequential Photographs, Test No. SFH-2



0.000 sec



0.354 sec



0.020 sec



0.664 sec



0.068 sec



1.156 sec



0.218 sec



3.198 sec

Figure 61. Additional Sequential Photographs, Test No. SFH-2



0.000 sec



0.330 sec



0.046 sec



0.664 sec



0.098 sec



1.130 sec



0.176 sec



3.196 sec

Figure 62. Additional Sequential Photographs, Test No. SFH-2



0.000 sec



0.170 sec



0.050 sec



0.206 sec



0.098 sec



0.304 sec

Figure 63. Additional Sequential Photographs, Test No. SFH-2



Figure 64. Documentary Photographs, Test No. SFH-2

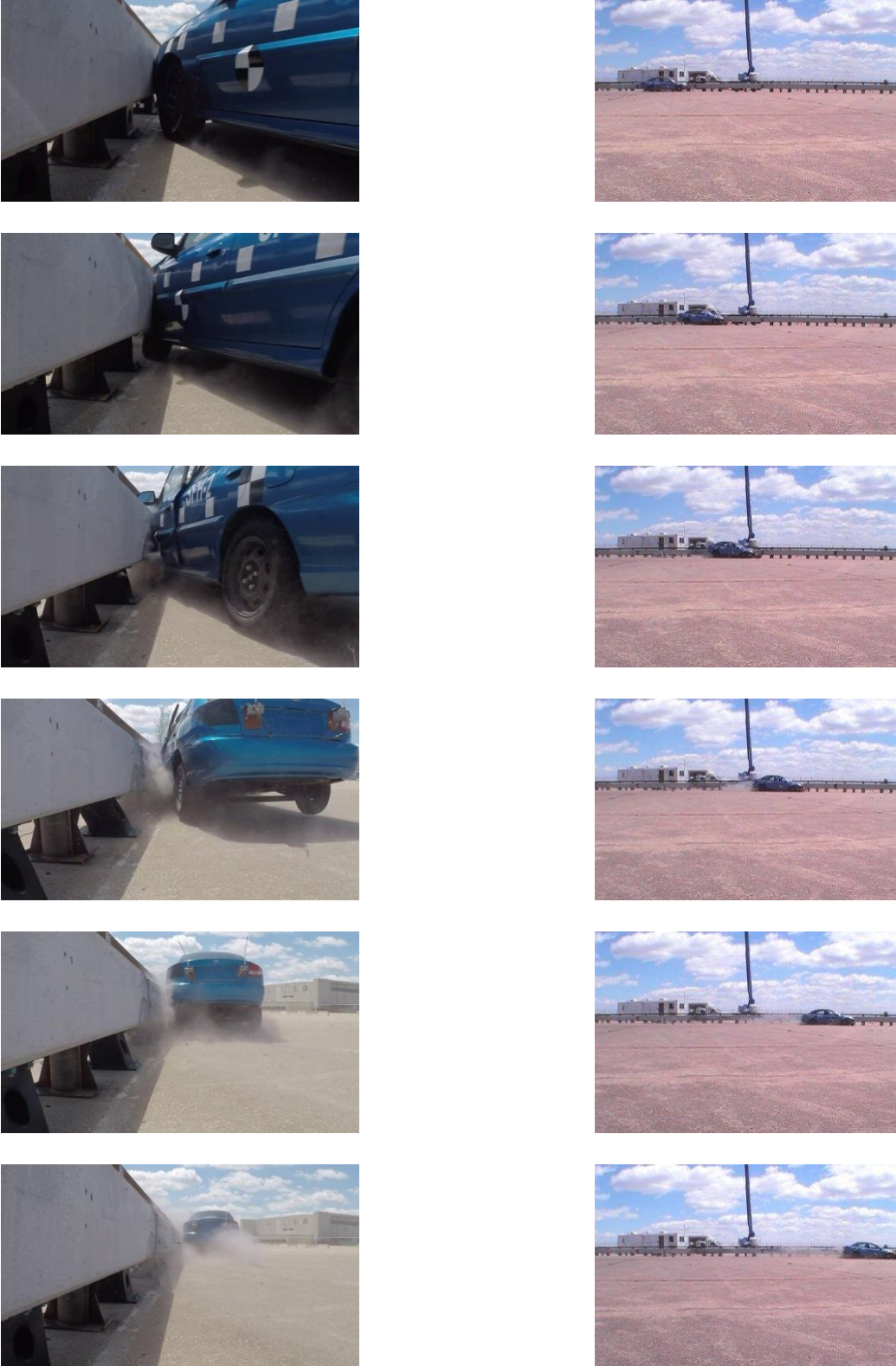

Figure 65. Documentary Photographs, Test No. SFH-2



Figure 66. Documentary Photographs, Test No. SFH-2



Figure 67. Impact Location, Test No. SFH-2



Figure 68. Vehicle Final Position and Trajectory Marks, Test No. SFH-2



Figure 69. System Damage, Barrier No. 7, Test No. SFH-2



Figure 70. System Damage, Barrier No. 8, Test No. SFH-2



a) First Post Downstream from Joint between Barrier Nos. 7 and 8



b) Second Post Downstream from Joint between Barrier Nos. 7 and 8

Figure 71. System Damage, Rubber Post Damage, Barrier No. 8, Test No. SFH-2



Figure 72. System Damage, Barrier Nos. 11 and 12, Test No. SFH-2



Figure 73. Vehicle Damage, Test No. SFH-2



Figure 74. Vehicle Damage, Test No. SFH-2

6.7 1100C Comparison to Rigid Barrier Tests

To determine if lateral accelerations were reduced, MASH test designation no. 4-10 crash tests with a vertical-faced, rigid concrete barrier were desired for comparison as they would likely produce the largest vehicle accelerations. However, crash test data was not available, so other rigid barrier crash tests were utilized.

The longitudinal and lateral vehicle accelerations, as measured at the vehicle's c.g., were also processed using a 50-msec moving average. The 50-msec moving average vehicle accelerations were then combined with the uncoupled yaw angle versus time data in order to estimate the vehicular loading applied to the barrier system. From the data analysis, the perpendicular impact force was determined for the RESTORE barrier, as shown in Figure 75. The maximum perpendicular, or lateral, load imparted to the barrier was 48.4 kips (215 kN) and 46.4 kips (206 kN) as determined by the SLICE-1 and SLICE-2, respectively.

The results of test no. SFH-2 were compared to the results of two different MASH test designation no. 4-10 crash tests, test no. 420020-6 with a vertical, steel median gate [15] and test no. 2214NJ-1 with a New Jersey concrete barrier [16]. Test comparisons are shown in Table 14 and Figure 76. The lateral barrier force was calculated in test nos. 420020-6 and 2214NJ-1 using the same procedure as used in test no. SFH-2. The lateral peak barrier forces were reduced by up to 15 percent than those observed with the vertical, steel median gate and up to 16 percent than those observed to the New Jersey concrete barrier. The peak lateral acceleration increased by up to 23 percent when compared to the vertical, steel median gate and reduced by up to 21 percent when compared to the New Jersey concrete barrier. The peak lateral acceleration may have been lower in the steel median gate; since, it had lower inertia and may have deformed more than a rigid barrier. However, after the peak acceleration, the RESTORE barrier had lower lateral accelerations as compared to the steel median gate and the New Jersey barrier, as shown in

Figures 77 and 78. Additionally, the RESTORE barrier reduced lateral OIV values by up to 31 percent. The lateral and longitudinal ORA values were similar across all tests and had little variances.

Overall, the RESTORE barrier reduced impact loads for both 2270P and 1100C vehicle impacts. However, the magnitude of these reductions were smaller for the 1100C vehicle. This finding was due to the lighter weight of the vehicle and the reduced deflection of the barrier system associated with 1100C impacts.

Table 14. Test and Force Comparisons, 1100C Vehicle

Test Agency	TTI	MwRSF	MWRSF	MWRSF
Description	Vertical Steel Median Gate	NJ barrier	RESTORE Barrier	
Test No.	420020-6	2214NJ-1	SFH-2 SLICE-1 (Primary)	SFH-2 SLICE-2
Reference	15	16	-	-
Vehicle	1100C	1100C	1100C	1100C
Test Inertial Weight lb (kg)	2,424 (1,100)	2,414 (1,095)	2,406 (1,091)	2,406 (1,091)
Impact Velocity mph (km/h)	62.6 (100.7)	60.83 (97.9)	64.32 (103.5)	64.32 (103.5)
Impact Angle degrees	24.6	26.1	24.8	24.8
IS kip-ft (kJ)	55.0 (74.6)	57.8 (78.4)	58.5 (79.3)	58.5 (79.3)
Lateral OIV ft/s (m/s)	31.20 (9.48)	-34.97 (-10.66)	25.59 (7.80)	24.38 (7.43)
Longitudinal OIV ft/s (m/s)	-26.54 (-8.09)	-16.17 (-4.93)	-26.51 (-8.08)	-26.31 (-8.02)
Lateral ORA g's	6.35	-8.09	8.19	7.35
Longitudinal ORA g's	-3.99	-5.46	-5.06	-4.86
CFC 180 (10 msec Ave) Peak Lateral Acceleration g's	26.5	37.0	32.5	29.3
Peak Barrier Force kips (kN)	54.8 (244)	55.2 (246)	48.4 (215)	46.4 (206)

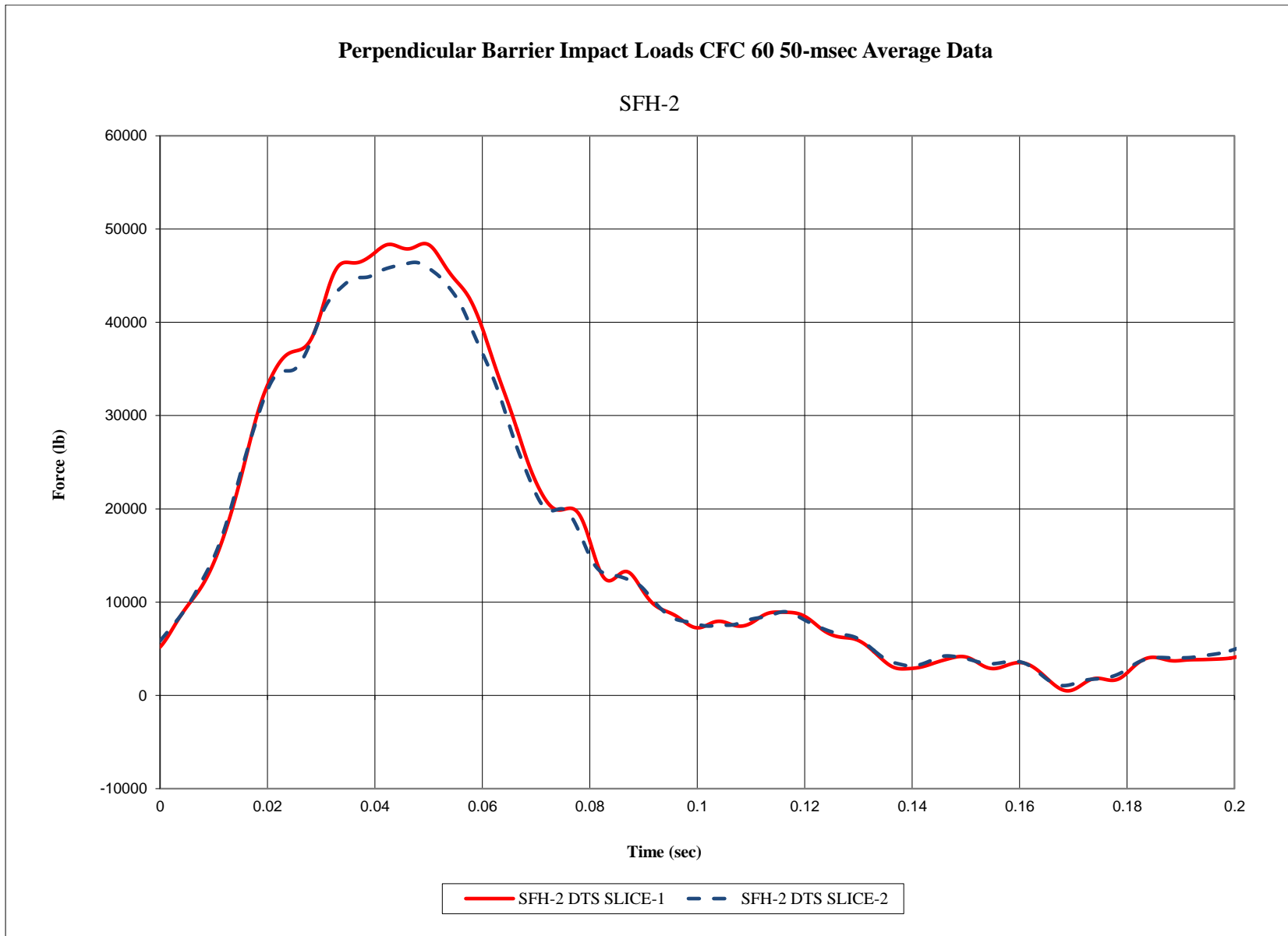

Figure 75. Perpendicular Forces Imparted to the Barrier System, Test No. SFH-2

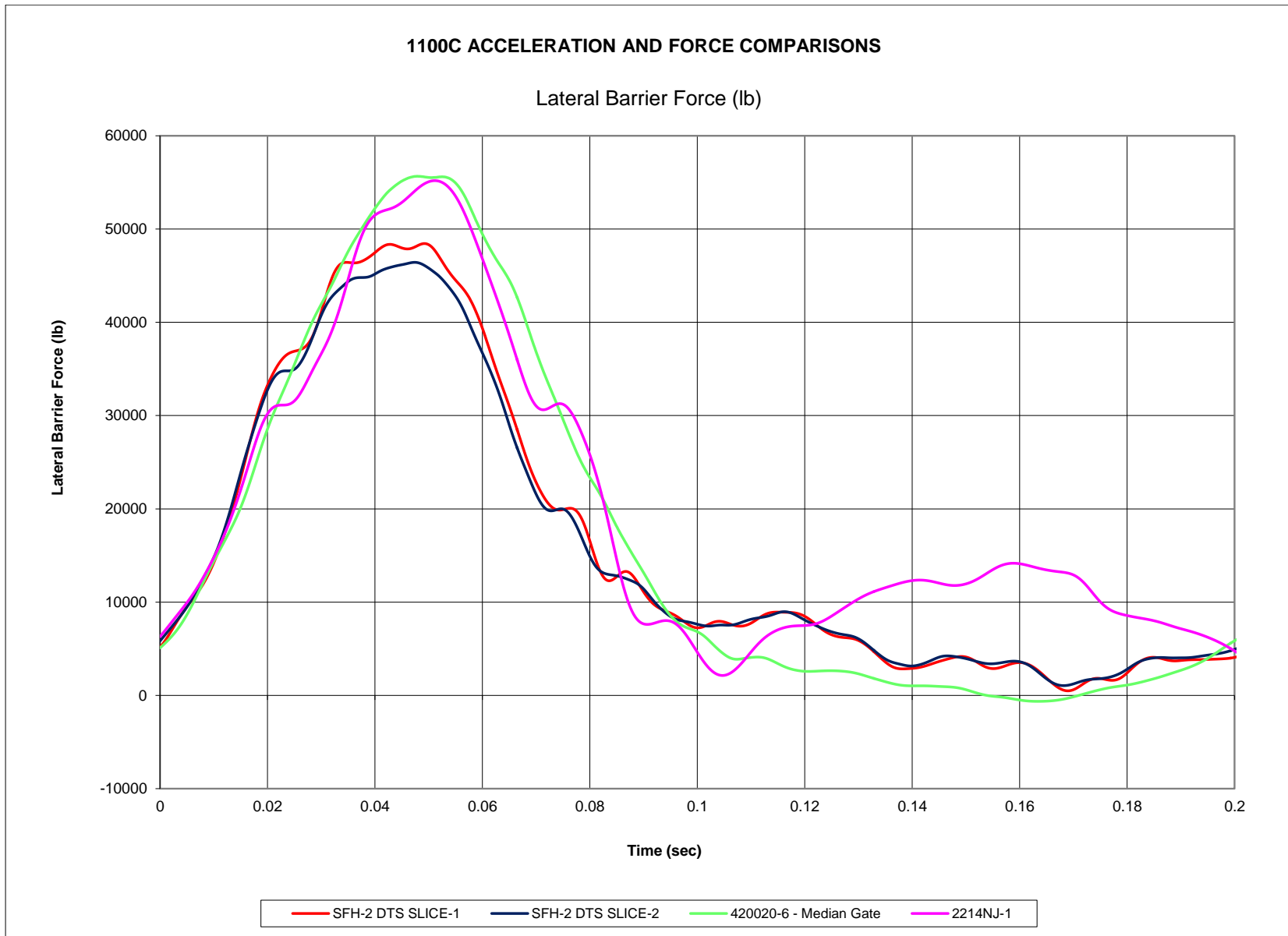

Figure 76. Force Comparisons, 1100C Vehicle

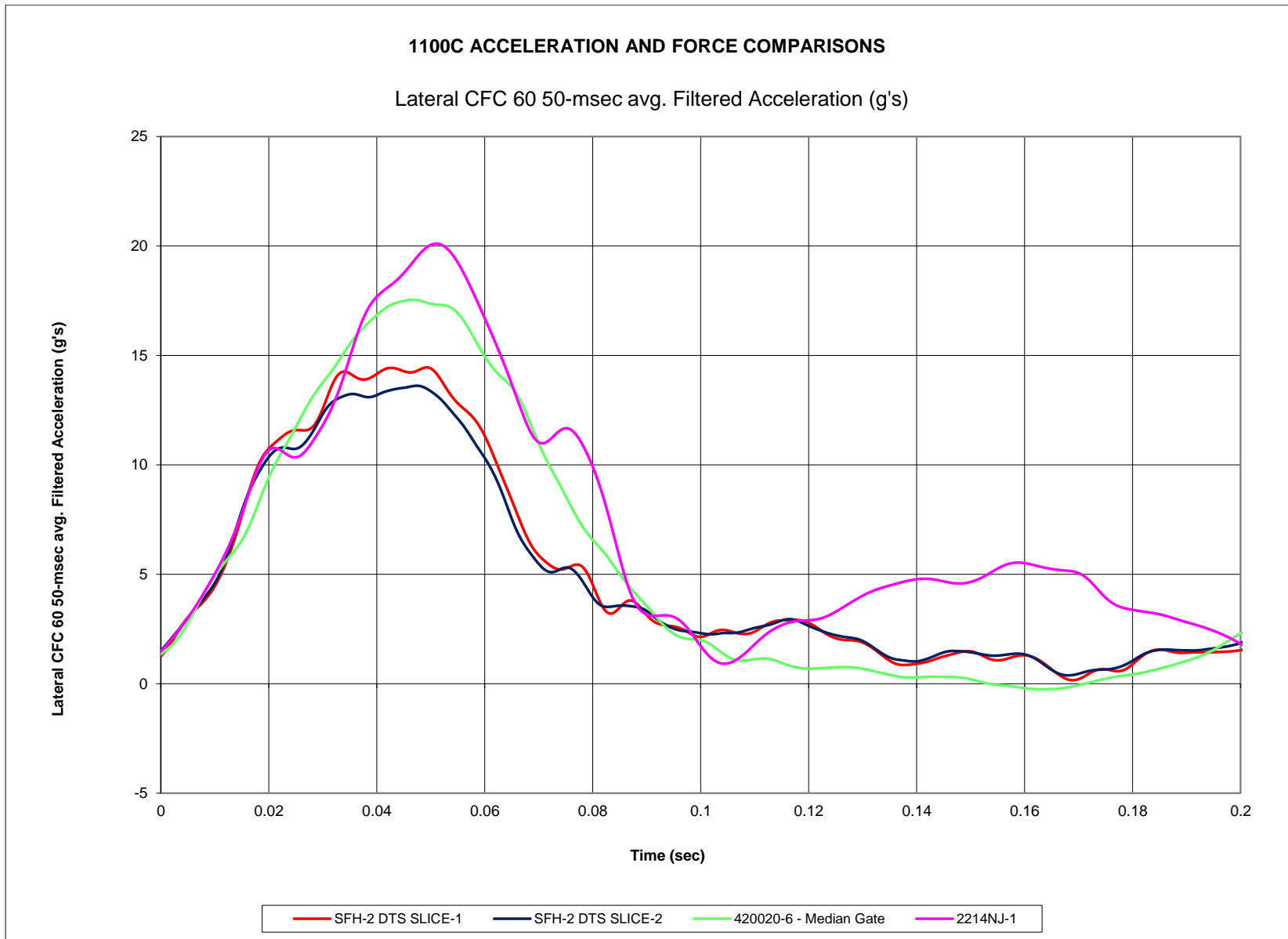

Figure 77. Lateral Acceleration Comparison, 1100C Vehicle

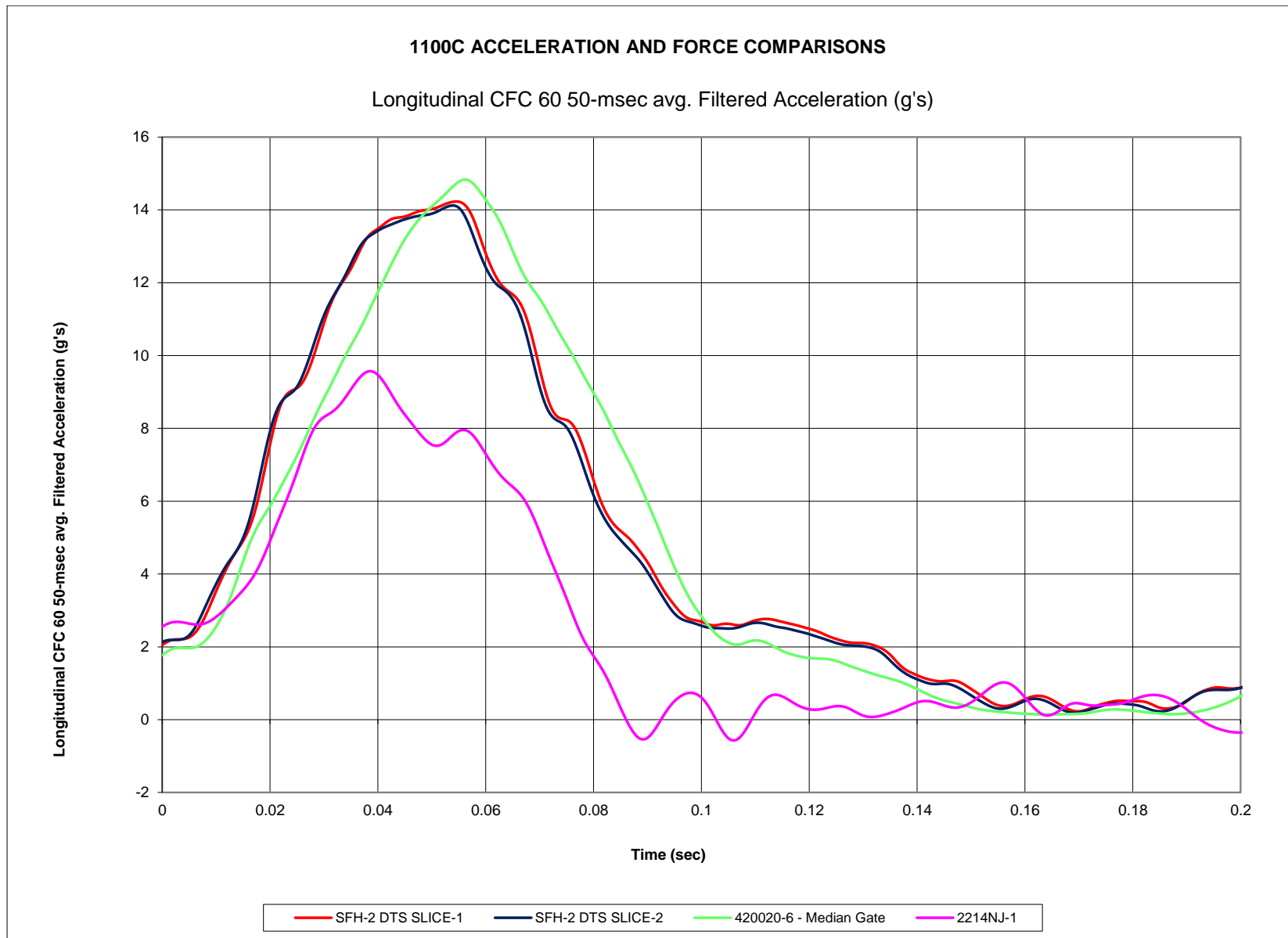

Figure 78. Longitudinal Acceleration Comparison, 1100C Vehicle

6.8 Discussion

The analysis of the test results for test no. SFH-2 showed that the RESTORE barrier adequately contained and redirected the 1100C vehicle with controlled lateral displacements of the barrier. There were no detached elements or fragments which showed potential for penetrating the occupant compartment or for presenting undue hazard to other traffic. Deformations of, or intrusions into, the occupant compartment that could have caused serious injury did not occur. The test vehicle did not penetrate or ride over the barrier and remained upright during and after the collision. Vehicle roll, pitch, and yaw angular displacements, as shown in Appendix D, were deemed acceptable, because they did not adversely influence occupant risk safety criteria or cause rollover. After impact, the vehicle exited the barrier at an angle of 4.6 degrees, and its trajectory did not violate the bounds of the exit box. Therefore, test no. SFH-2, conducted on the energy-absorbing concrete median barrier, was determined to be acceptable according to the MASH safety performance criteria for test designation no. 4-10.

7 DESIGN DETAILS, TEST NO. SFH-3

The installation for test no. SFH-3 was similar to the system used in test nos. SFH-1 and SFH-2, as shown in Figures 79 through 101. The impact point was moved, as shown in Figure 79. The components were rearranged to move previously-damaged components out of the impact region. The four threaded rods that attached the upper tube assembly, concrete beams, and rubber posts were replaced with four $\frac{3}{4}$ -in. (19-mm) diameter bolts to minimize the extent that the bolts protrude above the concrete beams and to reduce vehicle snag on the bolts, as shown in Figure 102.

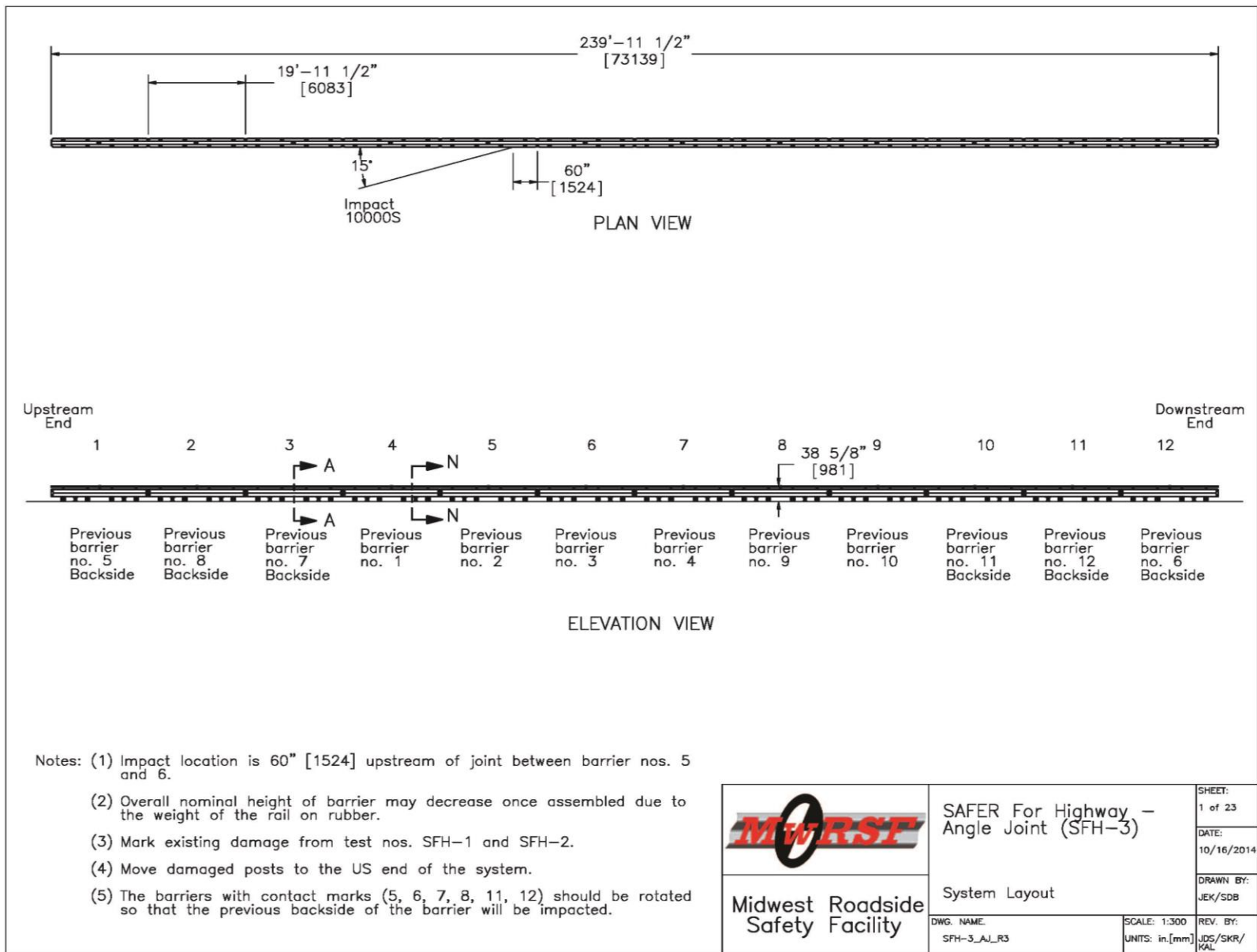

Figure 79. System Layout, Test No. SFH-3

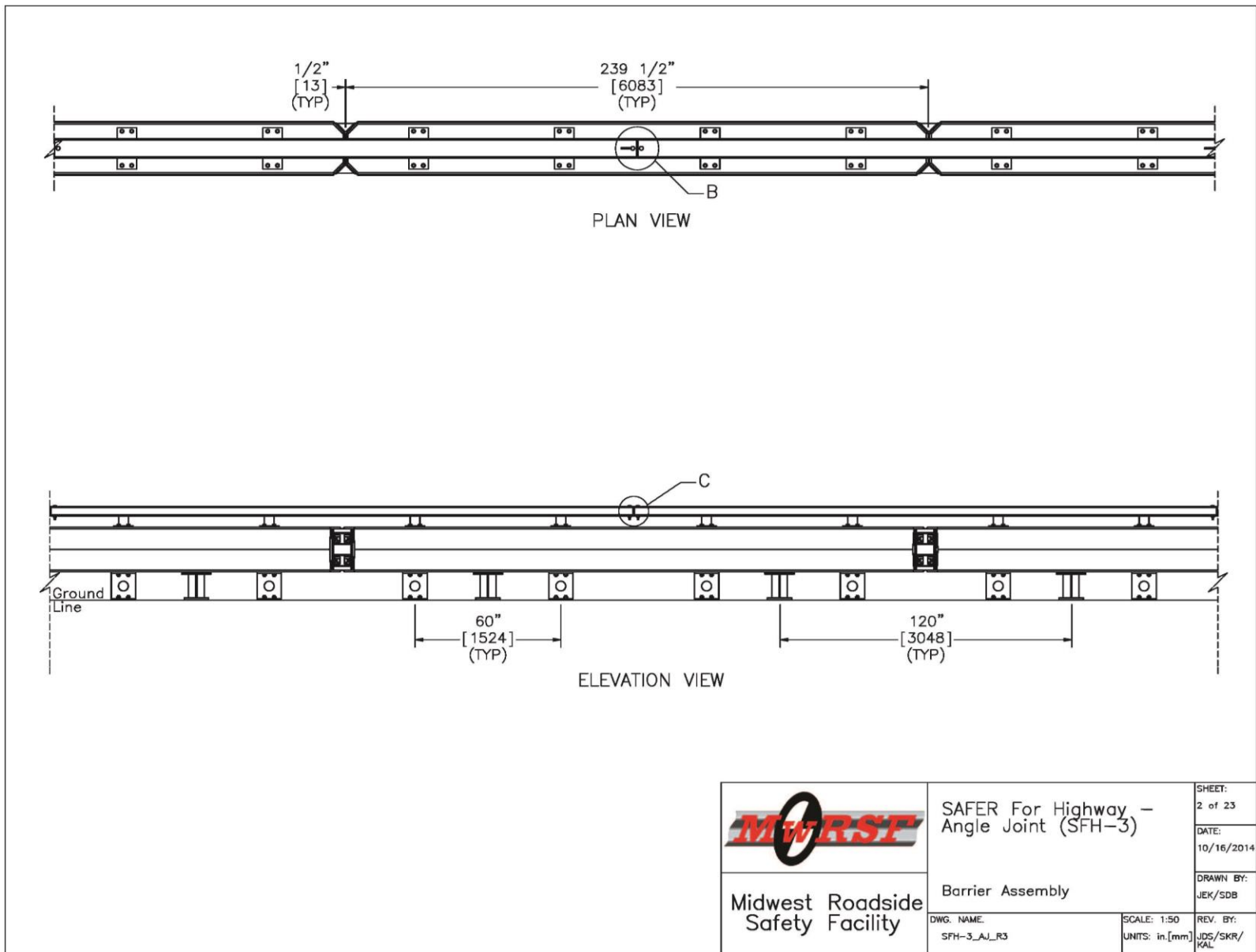

Figure 80. Barrier Assembly, Test No. SFH-3

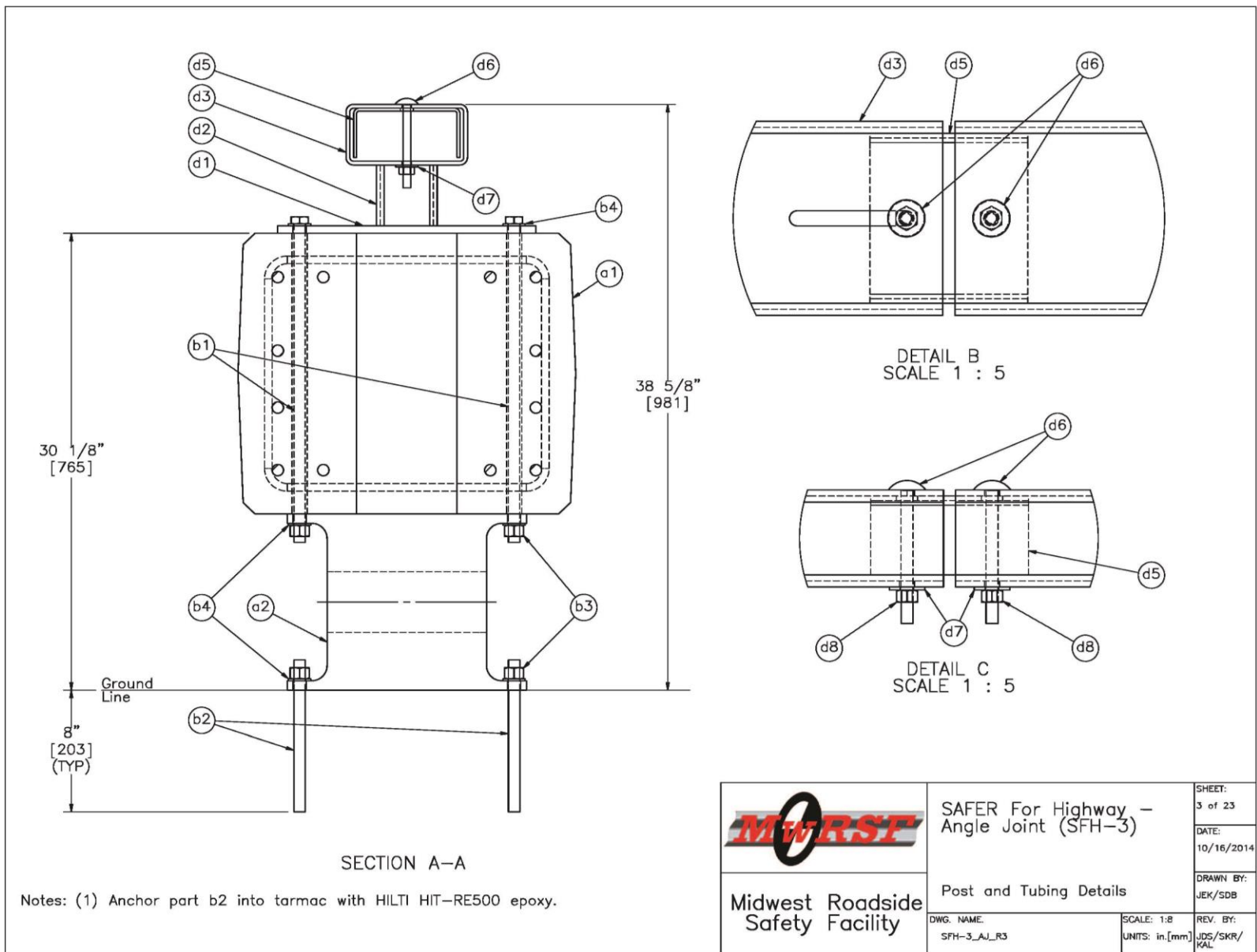

Figure 81. Post and Tubing Details, Test No. SFH-3

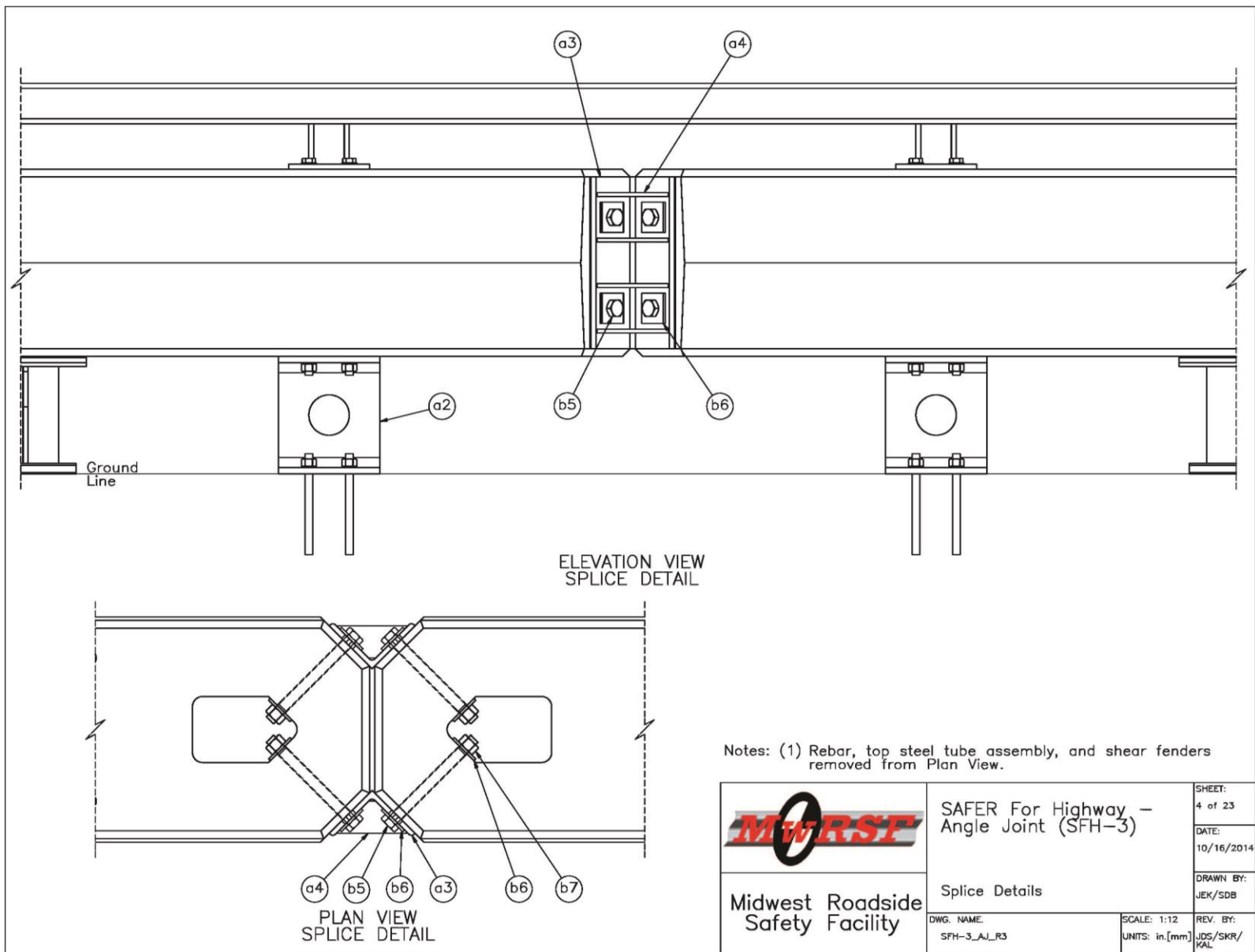

Figure 82. Splice Details, Test No. SFH-3

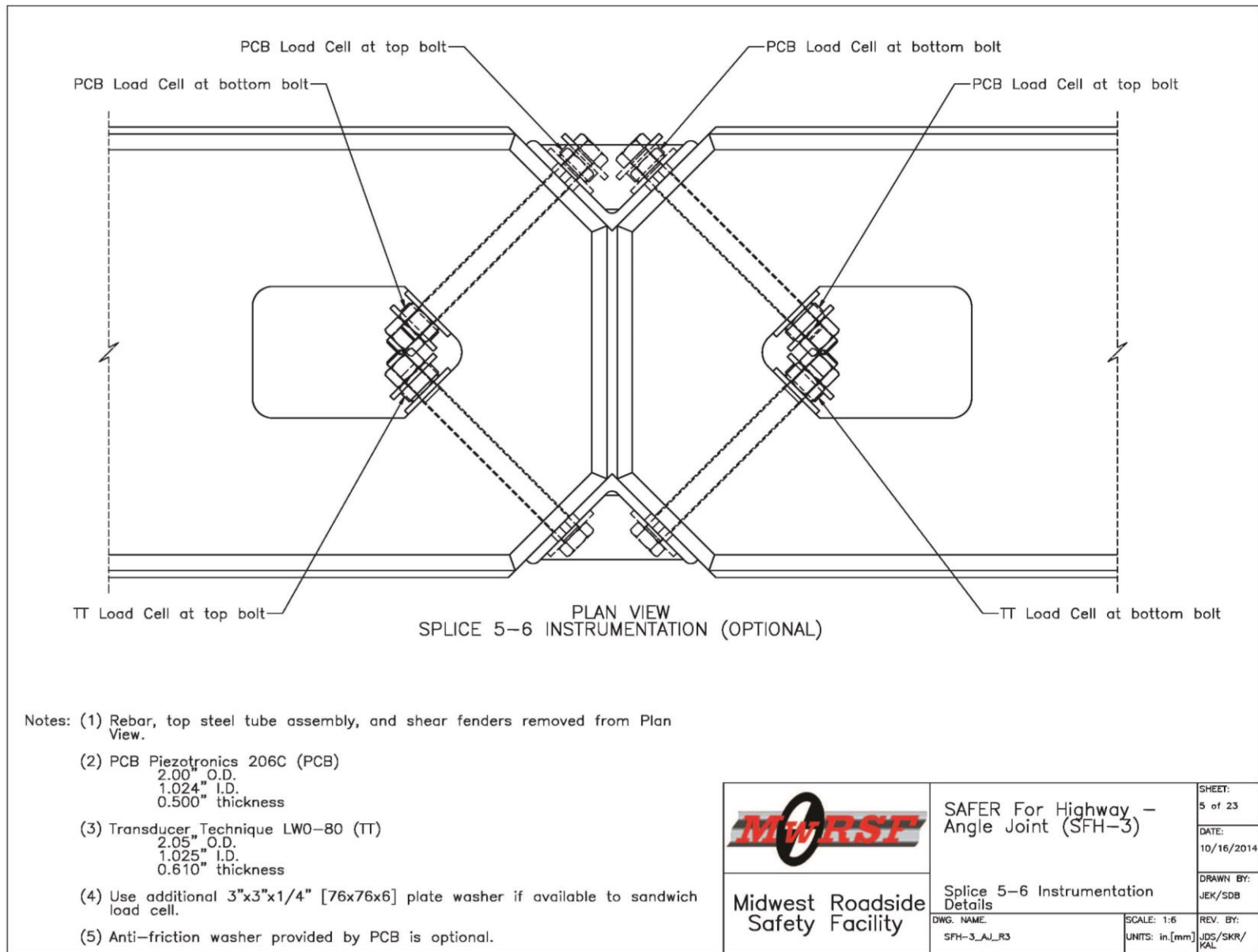

Figure 83. Splice 5-6 Instrumentation Details, Test No. SFH-3

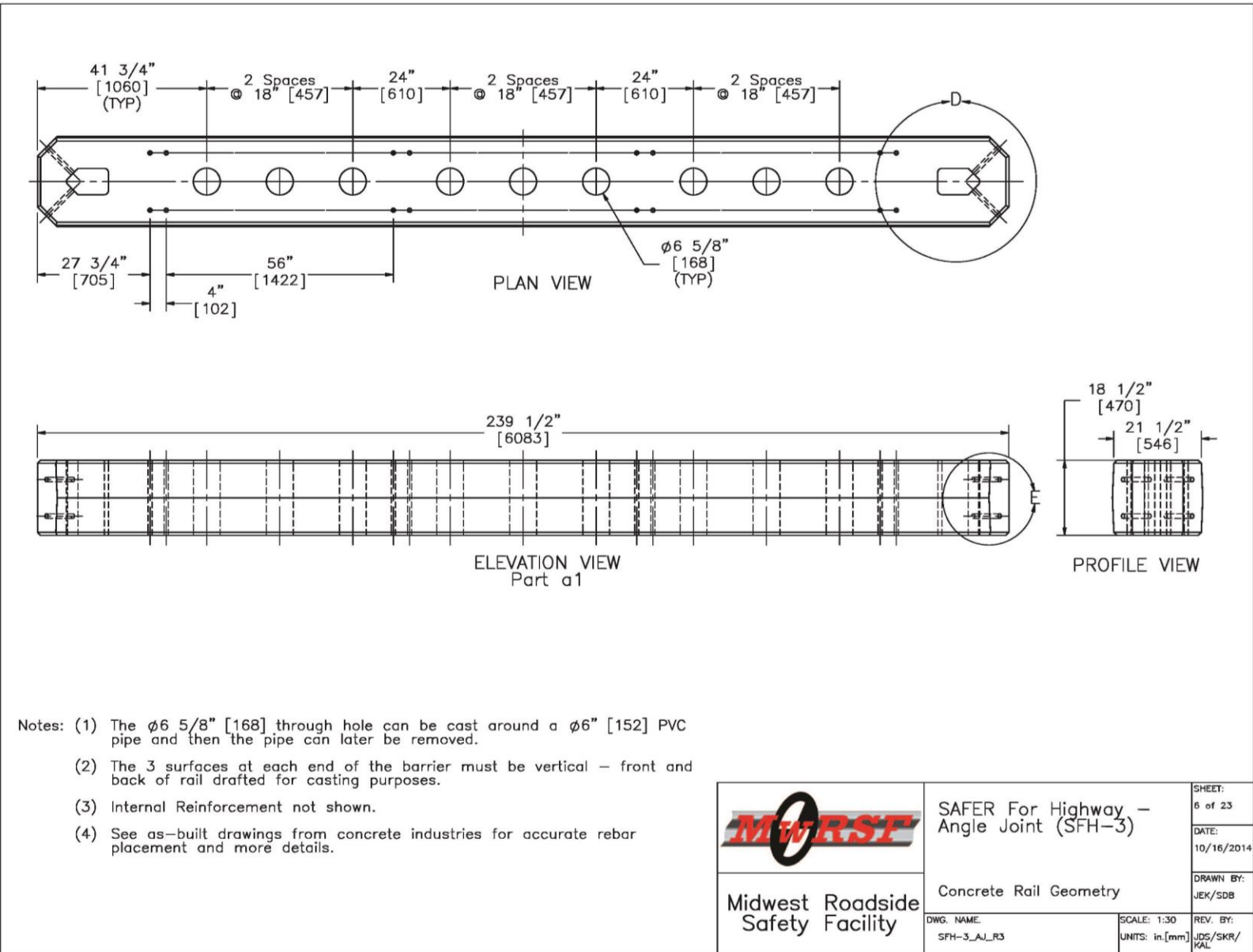

Figure 84. Concrete Beam Geometry, Test No. SFH-3

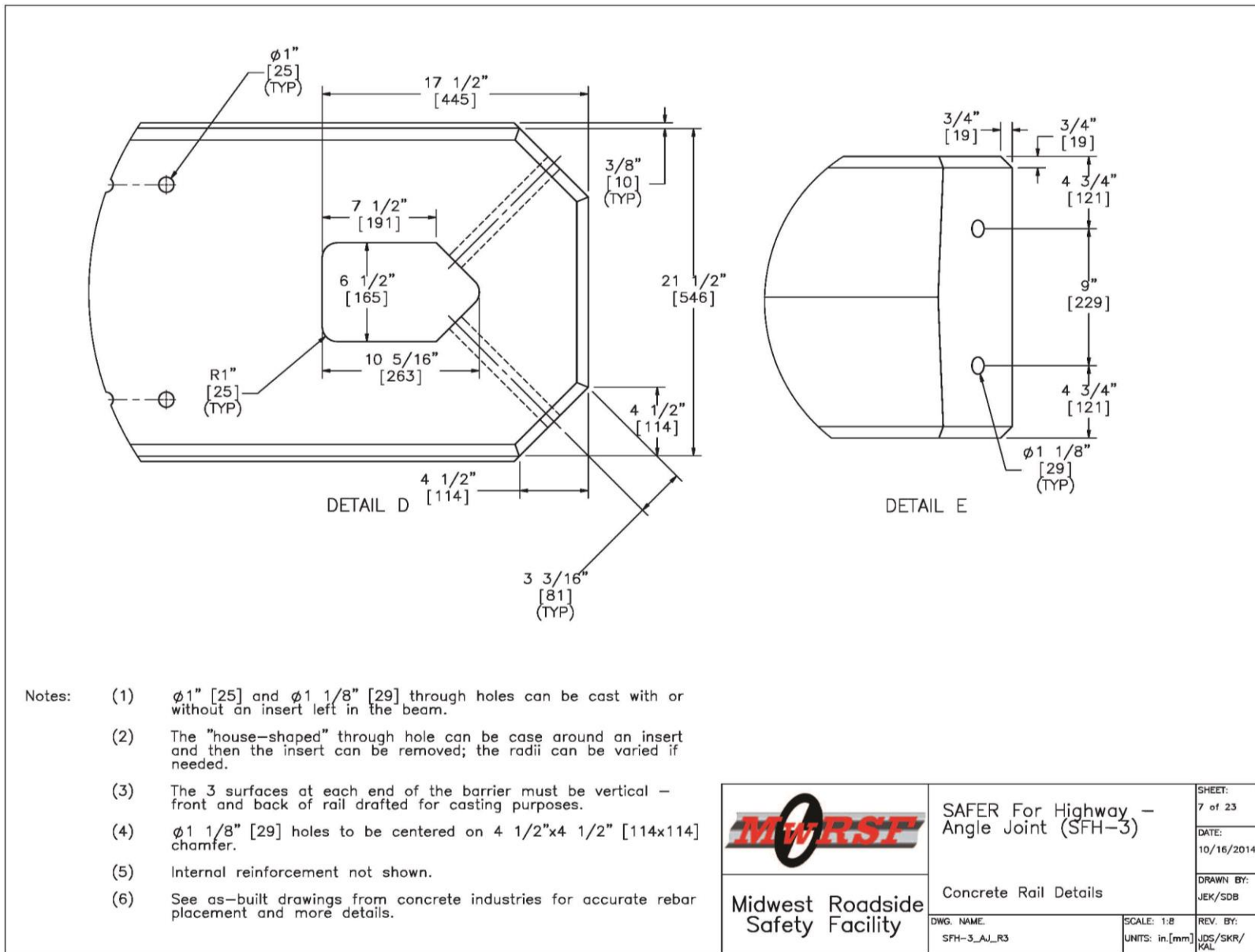

Figure 85. Concrete Beam Details, Test No. SFH-3

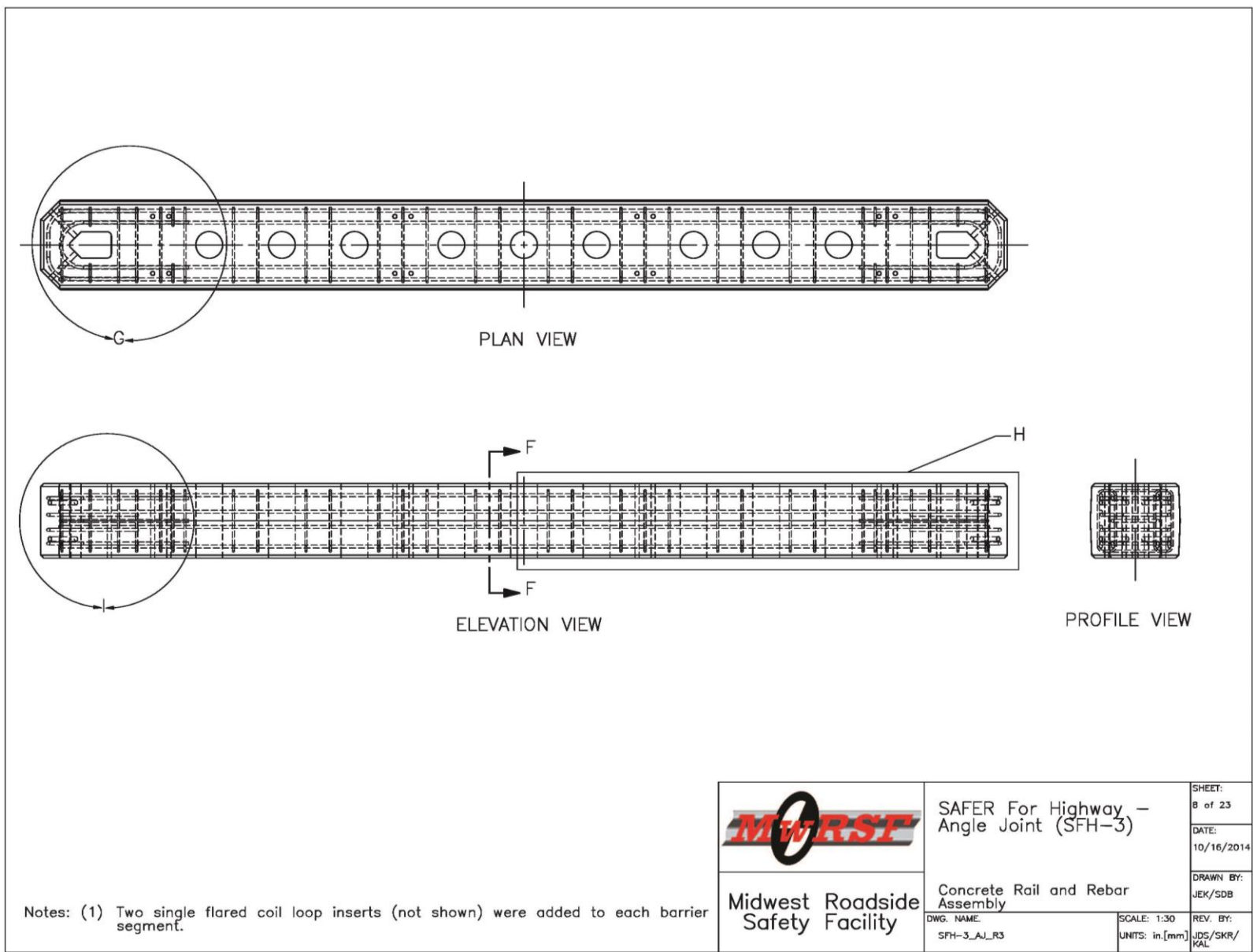

Figure 86. Concrete Beam and Rebar Assembly, Test No. SFH-3

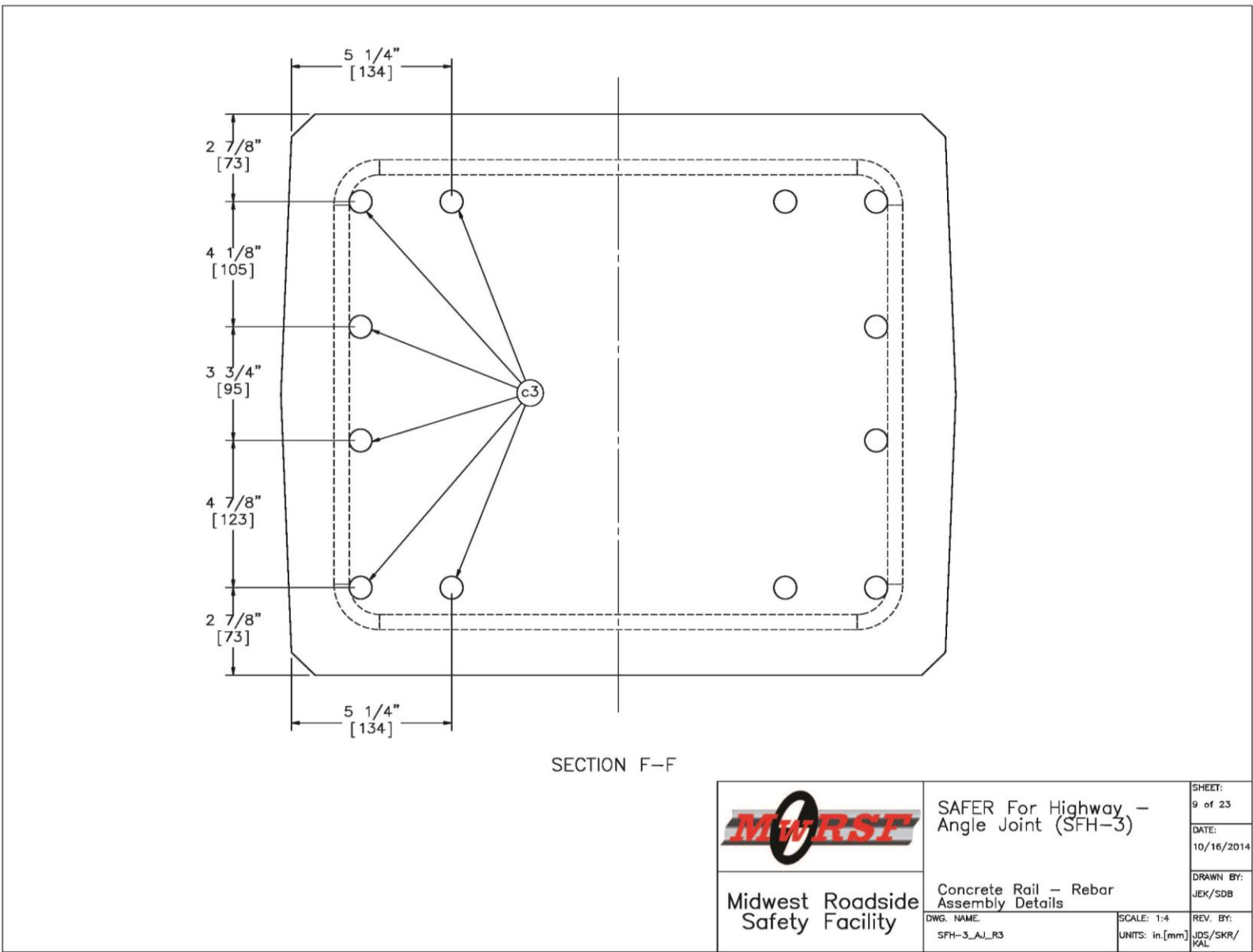

Figure 87. Concrete Beam, Rebar Assembly Details, Test No. SFH-3

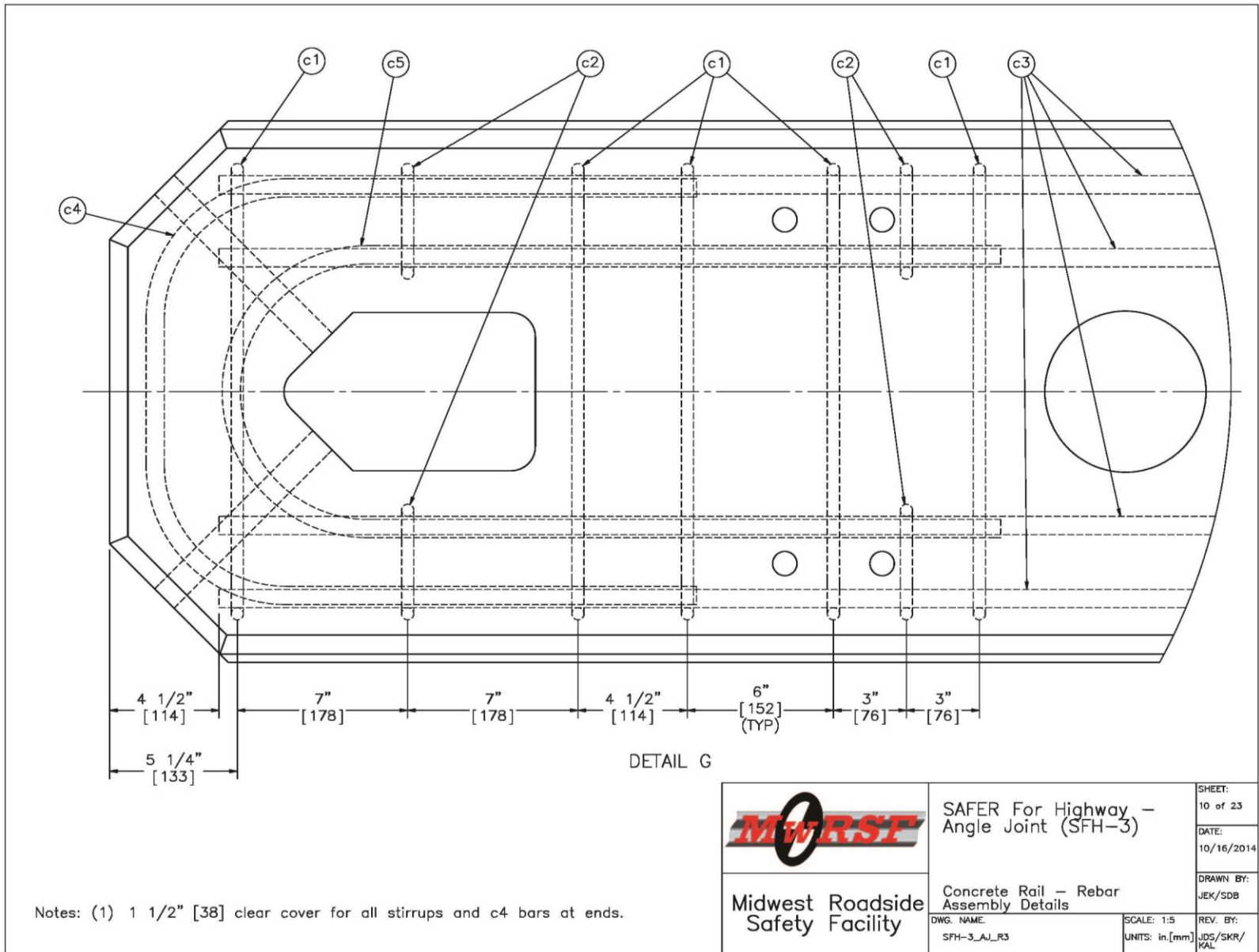

Figure 88. Concrete Beam, Rebar Assembly Details, Test No. SFH-3

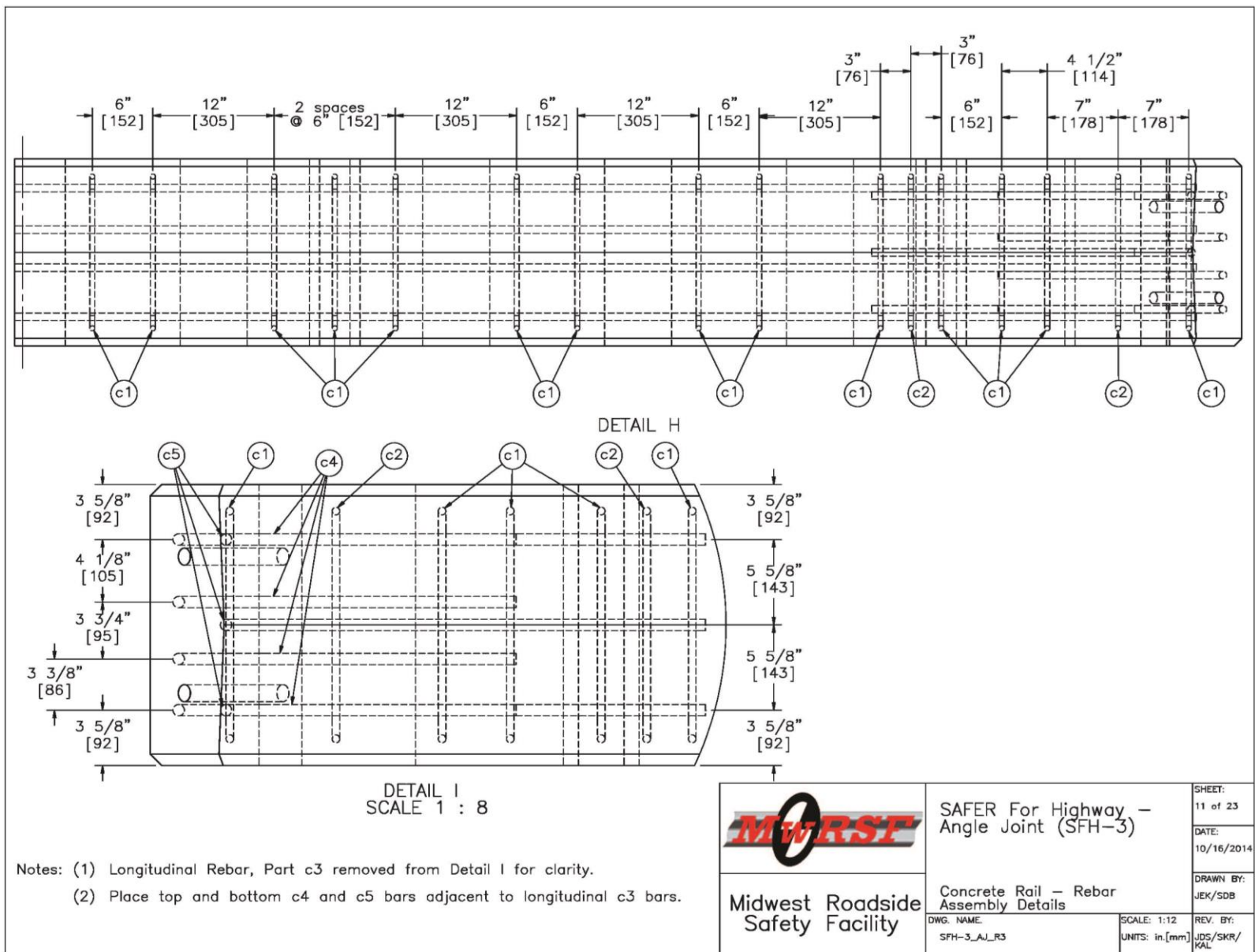

Figure 89. Concrete Beam, Rebar Assembly Details, Test No. SFH-3

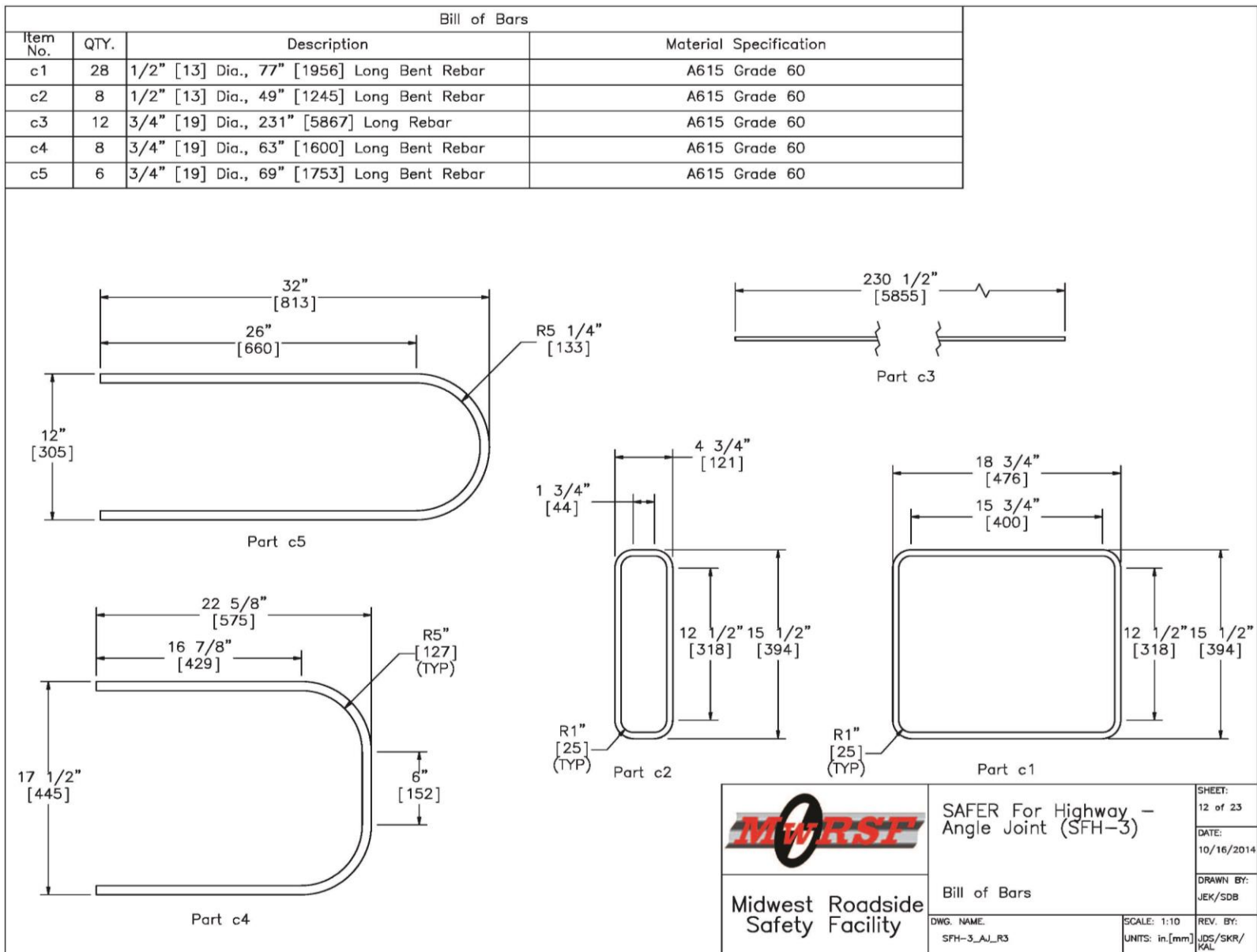

Figure 90. Bill of Bars, Test No. SFH-3

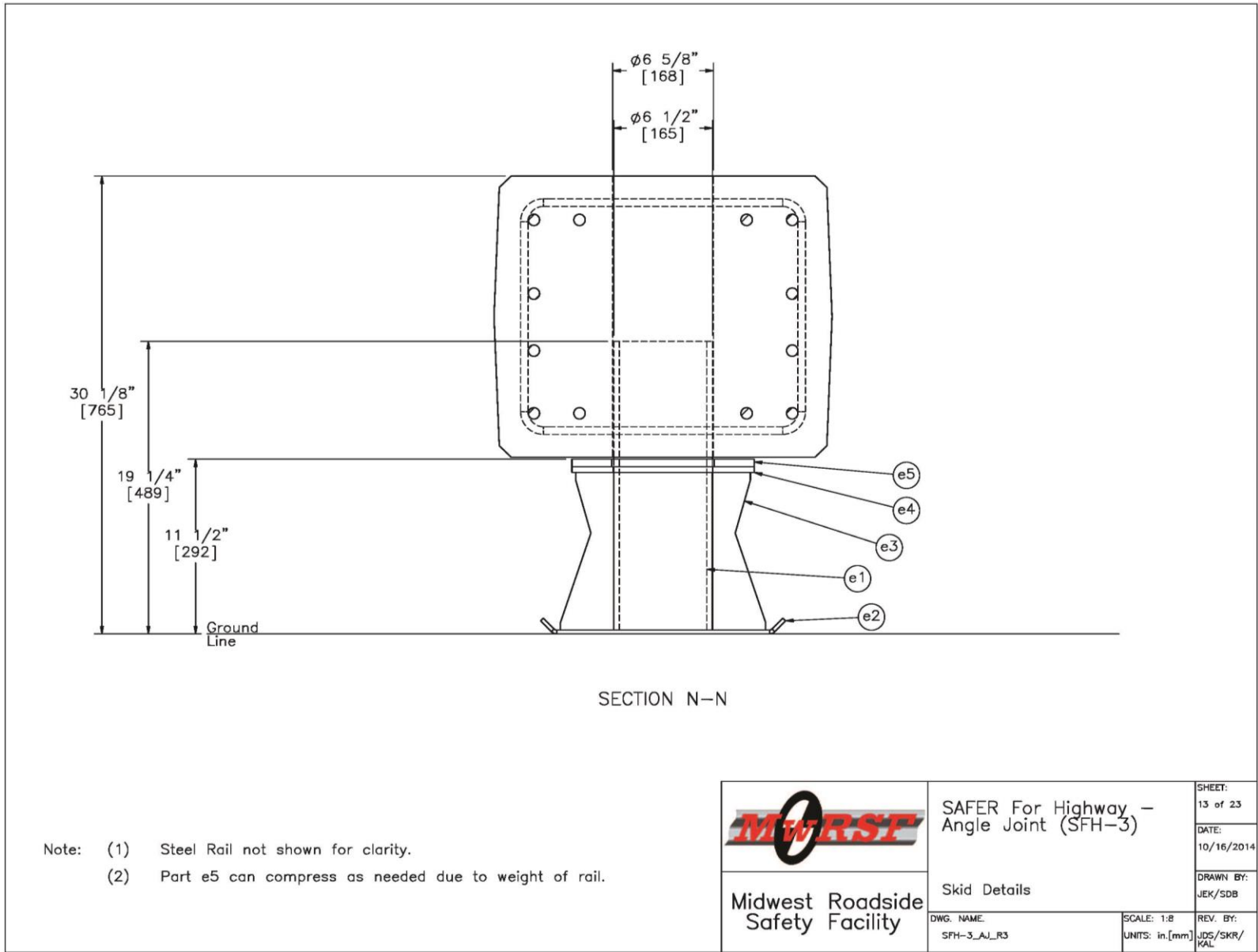

Figure 91. Skid Details, Test No. SFH-3

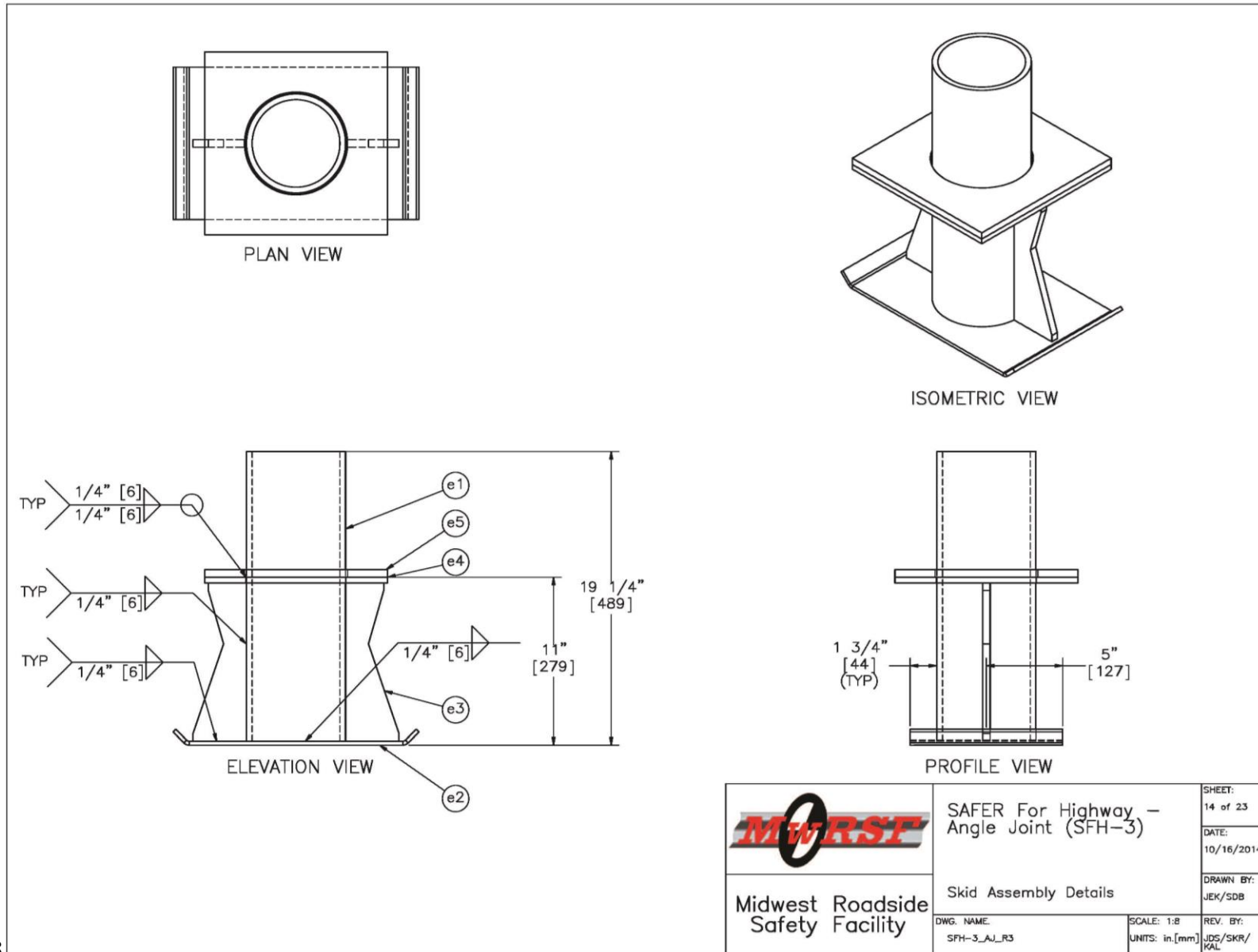

Figure 92. Skid Assembly Details, Test No. SFH-3

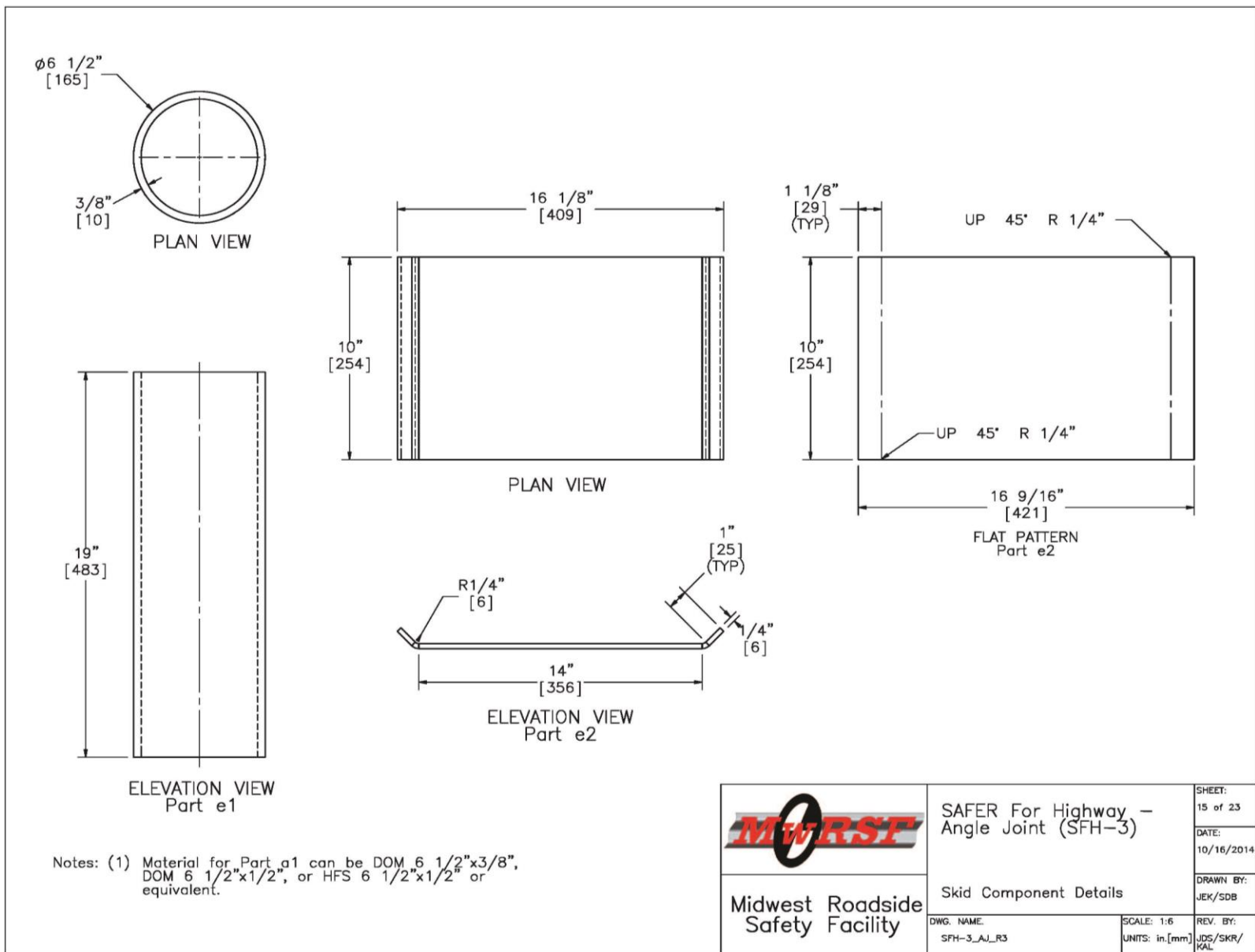

Figure 93. Skid Component Details, Test No. SFH-3

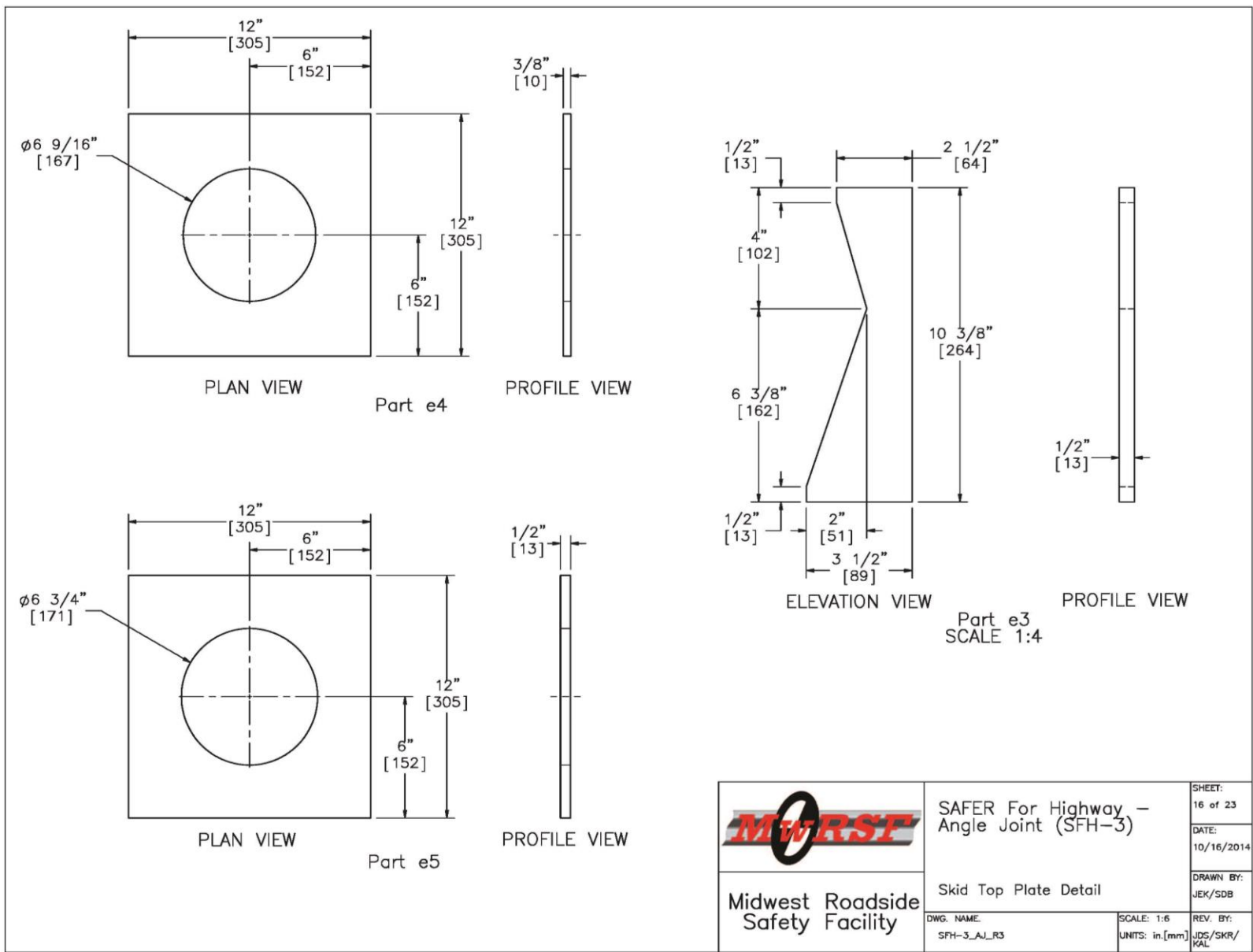

Figure 94. Skid Top Plate Detail, Test No. SFH-3

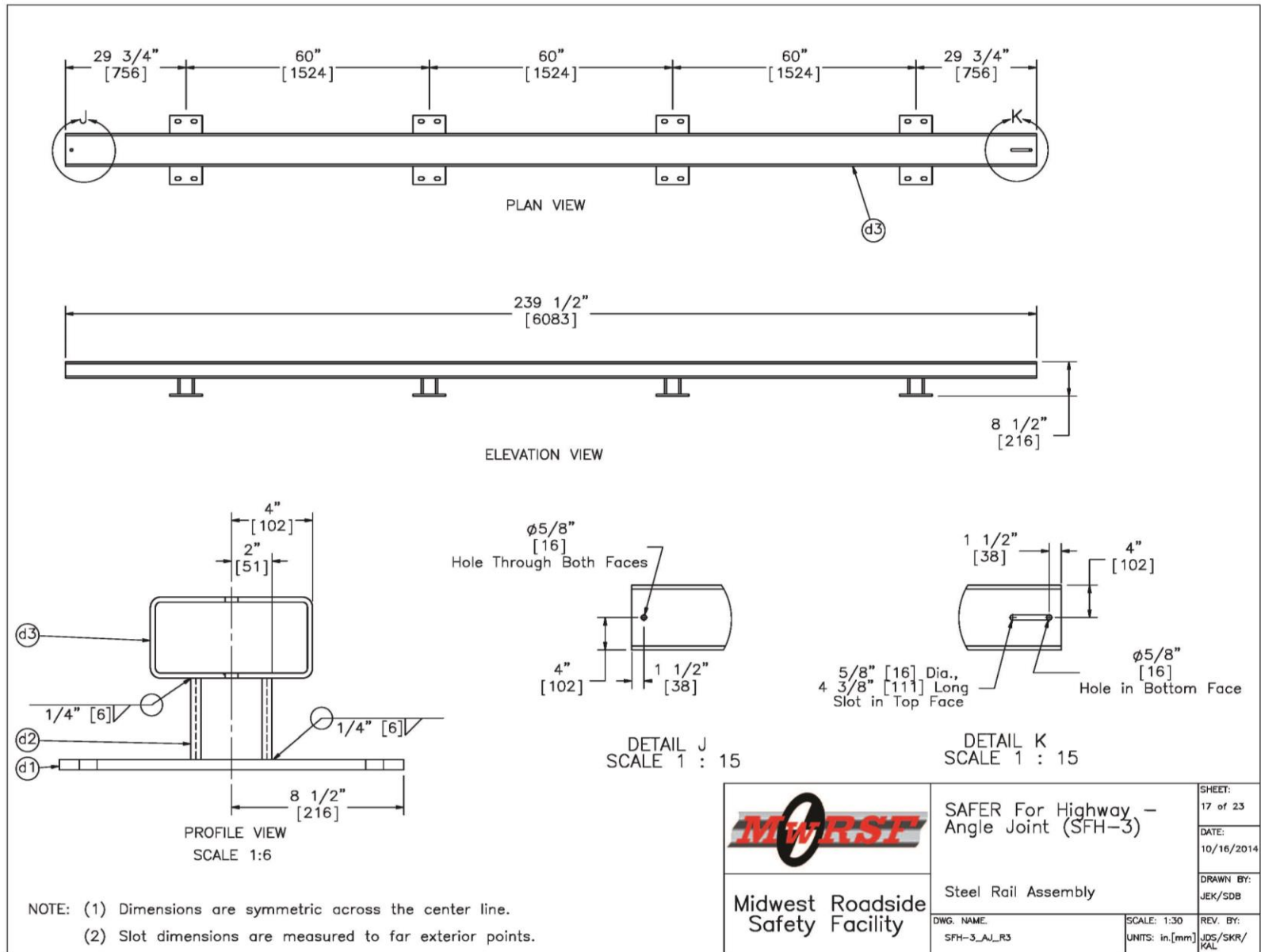

Figure 95. Upper Tube Assembly, Test No. SFH-3

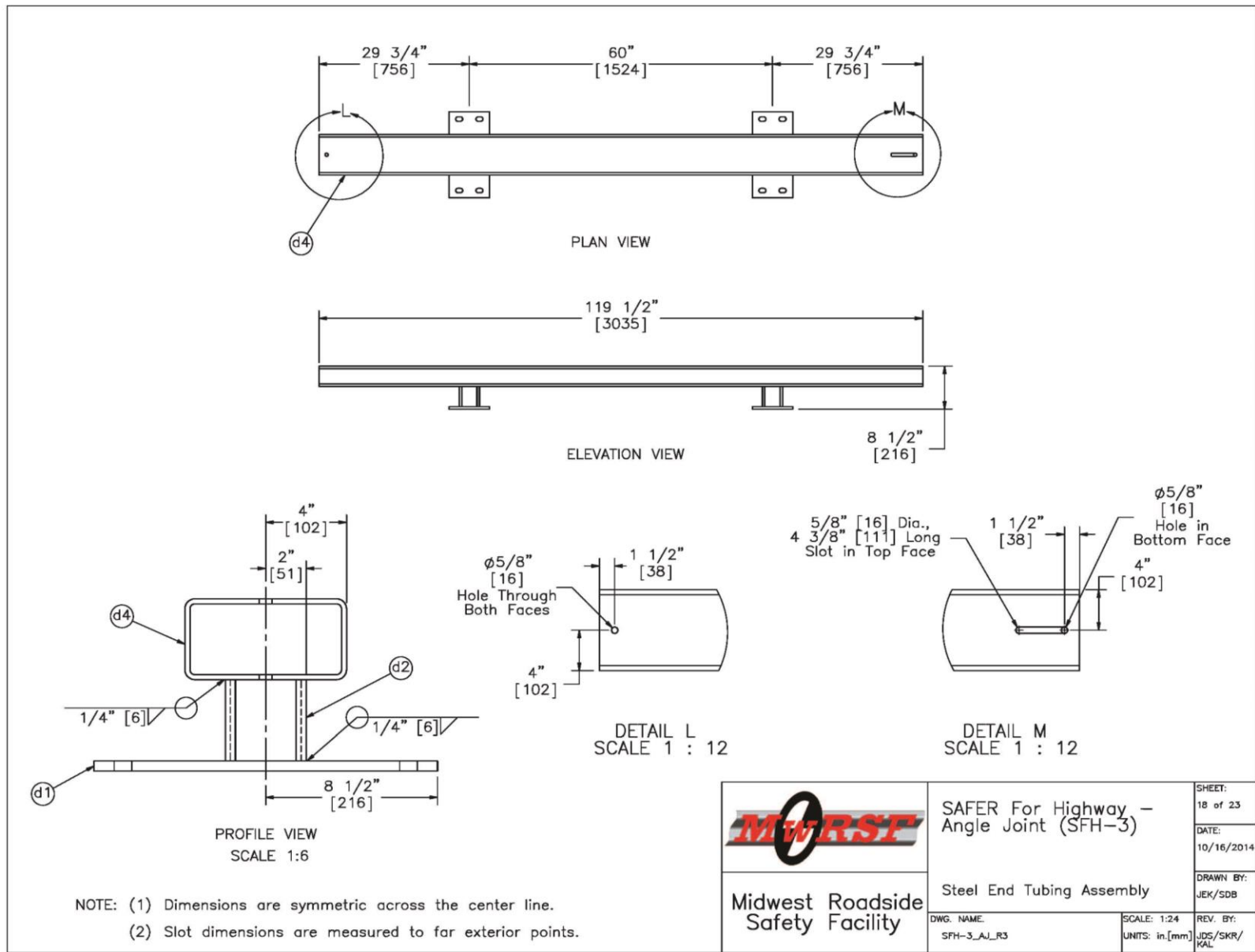

Figure 96. Steel End Tubing Assembly, Test No. SFH-3

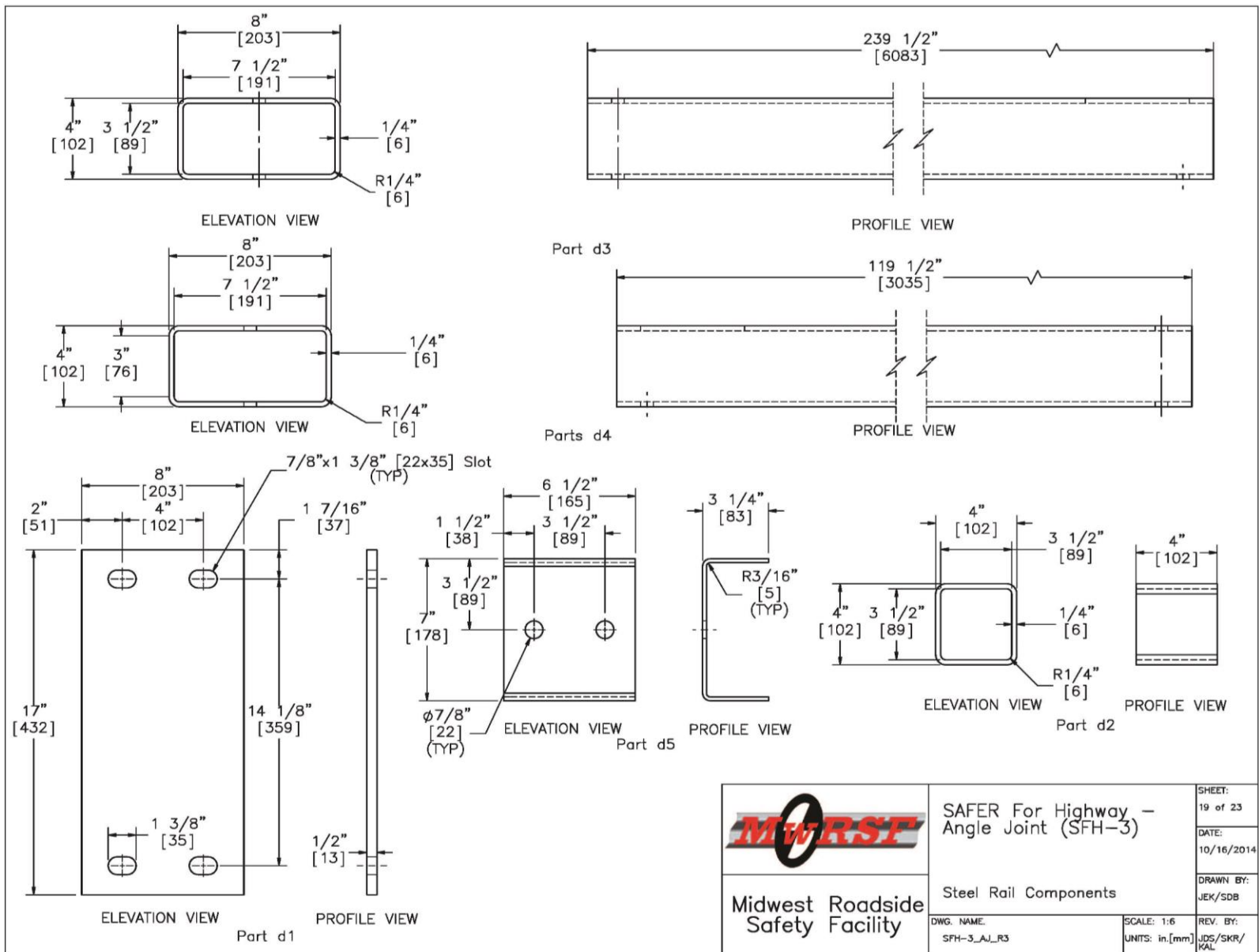

Figure 97. Steel Tubing Components, Test No. SFH-3

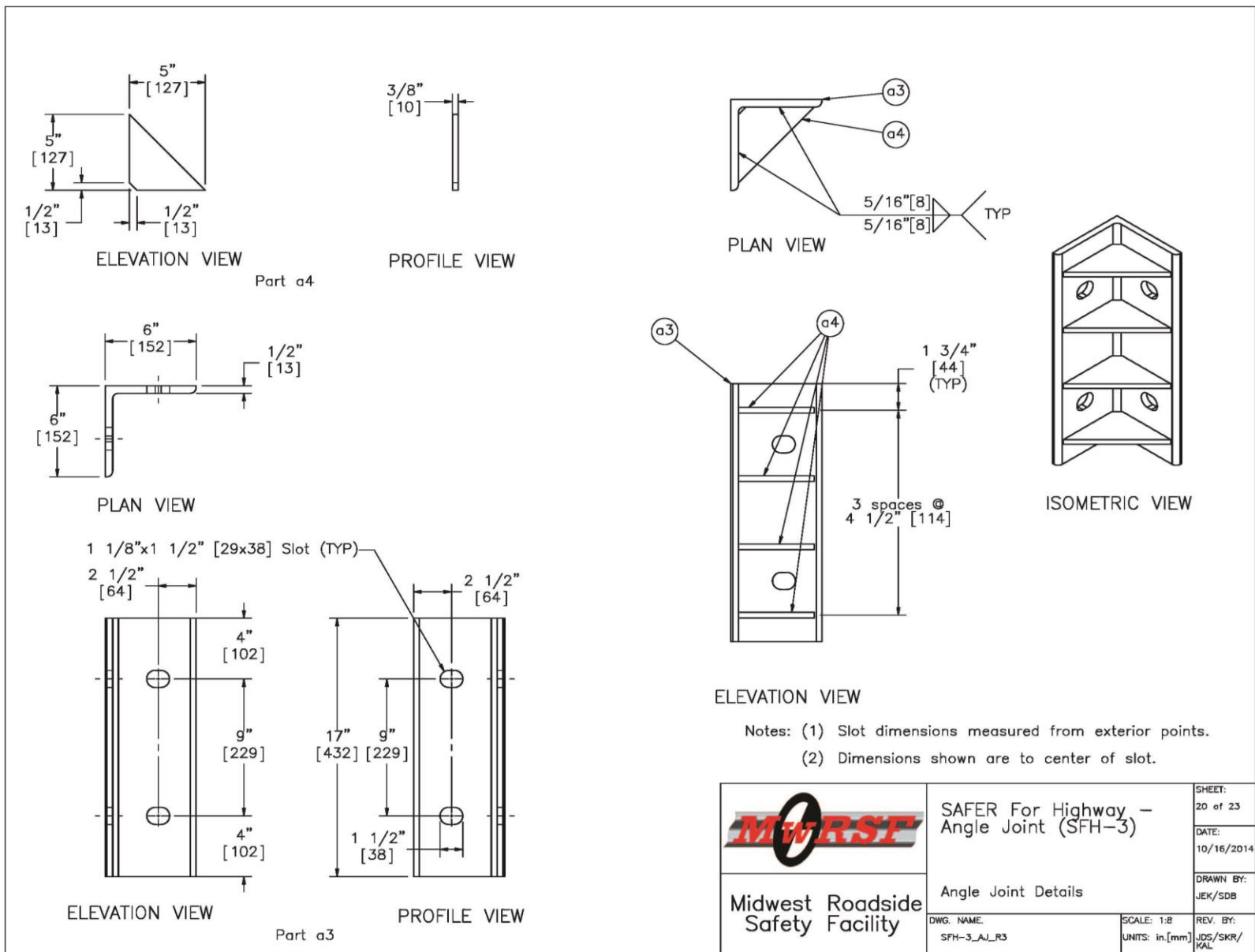

Figure 98. Angle Joint Details, Test No. SFH-3

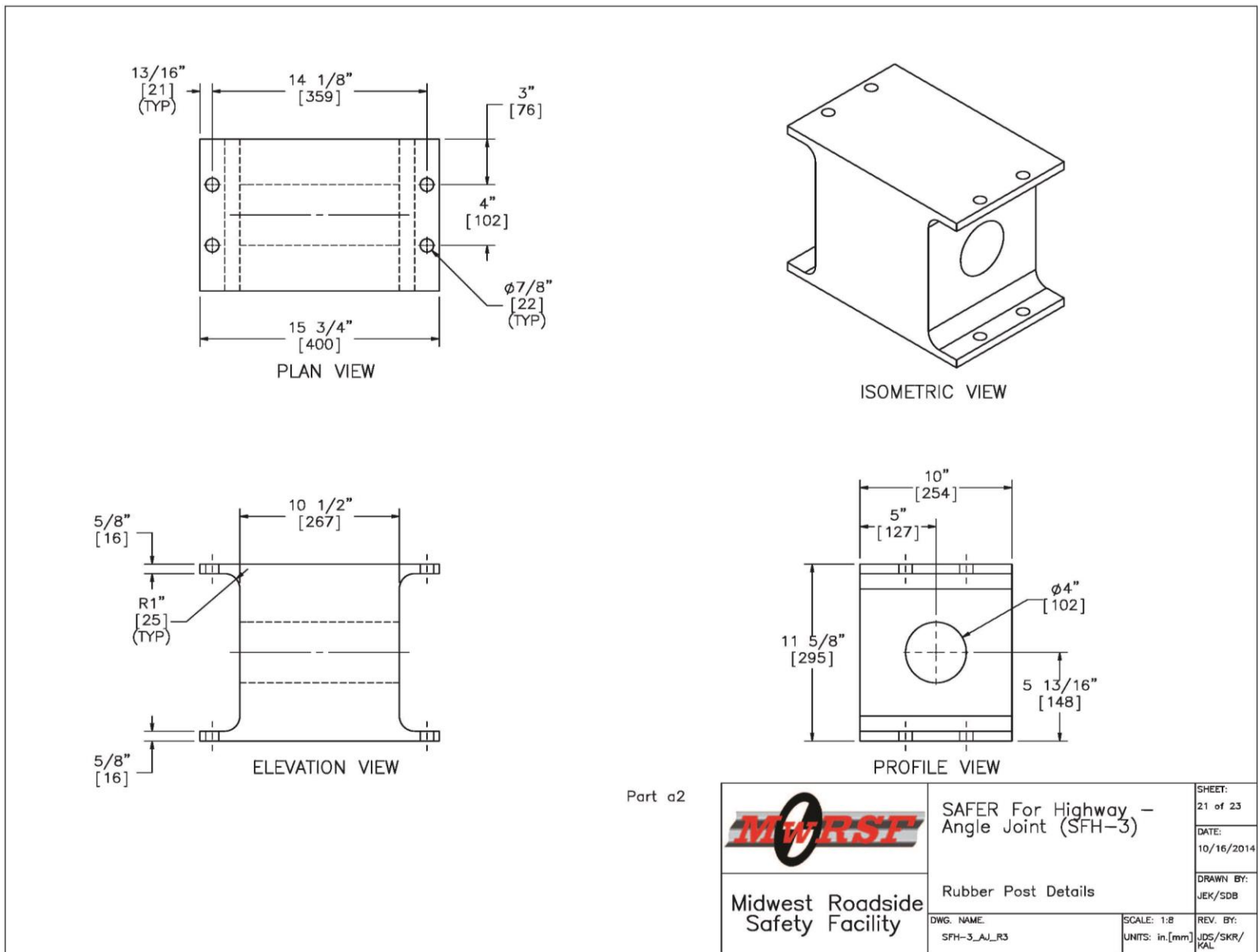

Figure 99. Rubber Post Details, Test No. SFH-3

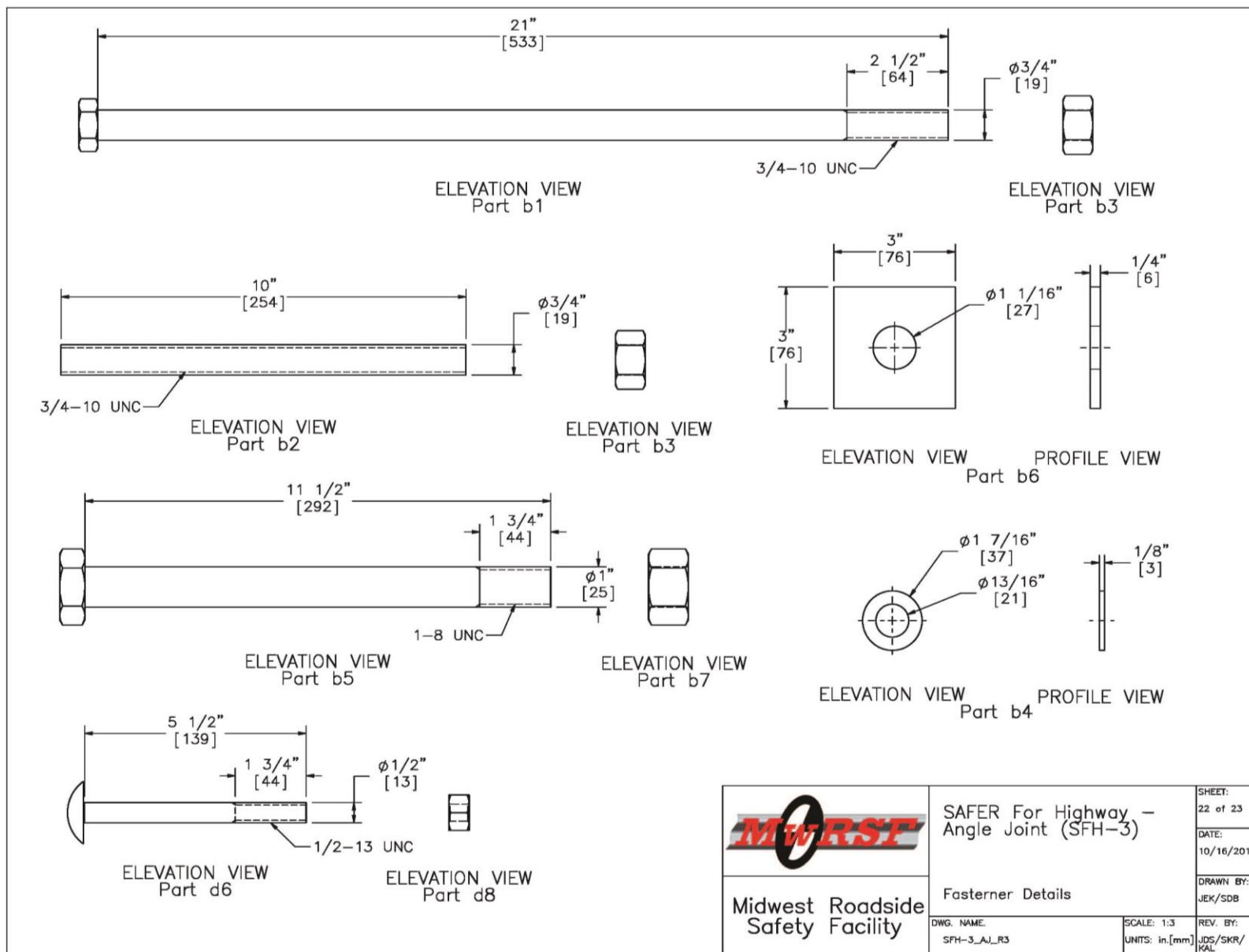

Figure 100. Fastener Details, Test No. SFH-3

Item No.	QTY.	Description	Material Specification	Hardware Guide
a1	12	Lightweight Concrete Rail	min f'c=5 ksi [34.5 MPa], density=110 pcf	—
a2	48	Morse E46496 Shear Fender	ASTM D2000	—
a3	22	6"x6"x1/2" [152x152x13], 17" [432] Long L-Bracket	A992 Galvanized	—
a4	88	5"x5"x3/8" [127x127x10] Gusset Plate	A572 Grade 50 Galvanized	—
b1	192	3/4" [19] Dia. UNC, 21" [533] Long Hex Bolt	Grade 5 Galvanized	FBX20a
b2	192	3/4" [19] Dia. UNC, 10" [254] Long Threaded Rod	ASTM A193 Grade B7 Galvanized	—
b3	384	3/4" [19] Dia. UNC Heavy Hex Nut	ASTM A194 Grade 2H Galv.	—
b4	576	3/4" [19] Dia. Flat Washer	ASTM F436 Galv.	—
b5	88	1" [25] Dia. UNC, 11 1/2" [292] Long Hex Head Bolt	ASTM A325 Galv.	FBX24b
b6	176	3"x3"x1/4" [76x76x6] Square Washer	A572 Grade 50 Galvanized	—
b7	88	1" [25] Dia. UNC Heavy Hex Nut	ASTM A563 DH Galv.	FNX24b
c1	336	1/2" [13] Dia., 77" [1956] Long Bent Rebar	A615 Grade 60	—
c2	96	1/2" [13] Dia., 49" [1245] Long Bent Rebar	A615 Grade 60	—
c3	144	3/4" [19] Dia., 231" [5867] Long Rebar	A615 Grade 60	—
c4	96	3/4" [19] Dia., 63" [1600] Long Bent Rebar	A615 Grade 60	—
c5	72	3/4" [19] Dia., 69" [1753] Long Bent Rebar	A615 Grade 60	—
d1	48	17"x8"x1/2" [431x203x13] Anchor Plate	ASTM A572 Grade 50 Galvanized	—
d2	48	4"x4"x1/4" [102x102x6], 4" [102] Long Tube	A500 Grade B Galvanized	—
d3	11	8"x4"x1/4" [203x102x6], 239 1/2" [6083] Long Tube	A500 Grade B Galvanized	—
d4	2	8"x4"x1/4" [203x102x6], 119 1/2" [3035] Long End Tube	A500 Grade B Galvanized	—
d5	12	12 3/4"x6 1/2"x3/16" [324x165x5] Bent Plate	ASTM A572 Grade 50 Galvanized	—
d6	24	1/2" [13] Dia. UNC, 5 1/2" [140] Long Dome (Round) Head Bolt	ASTM A307 Grade A Galvanized	—
d7	24	1/2" [13] Dia. Flat Washer	ASTM F844 Galvanized	FWC12a
d8	24	1/2" [13] Dia. UNC Heavy Hex Nut	A563A Galvanized	FNX12b
d9	—	Epoxy	HILTI HIT-RE500	—
e1	24	6 1/2" [165] Dia., 3/8" [10] Thick, 19" [483] Long Steel Pipe	AISI 1026	—
e2	24	16 9/16"x10"x1/4" [421x254x6] Base Plate	ASTM A572 Grade 50 Steel	—
e3	48	3 1/2"x10 3/8"x1/2" [89x264x13] Plate Gusset	ASTM A572 Grade 50 Steel	—
e4	24	12"x12"x3/8" [305x305x10] Top Plate	ASTM A572 Grade 50 Steel	—
e5	24	12"x12"x1/2" [305x305x13] EPDM Rubber Sheet	Minimum 50 durometer	—

 Midwest Roadside Safety Facility	SAFER For Highway – Angle Joint (SFH-3)	SHEET: 23 of 23
	Bill of Materials	DATE: 10/16/2014
DWG. NAME: SFH-3_AJ_R3	SCALE: 1:8 UNITS: in.[mm]	DRAWN BY: JEK/SDB
		REV. BY: JDS/SKR/ KAL

Figure 101. Bill of Materials, Test No. SFH-3



Figure 102. Upper Rail Assembly thru Bolt Connection, Test No. SFH-3

8 FULL-SCALE CRASH TEST NO. SFH-3

8.1 Weathering of the Barrier

After the system was installed, it was exposed to 6 months of winter weather conditions. With the rubber posts and steel plates attached, the vertical bolt holes in the concrete beams were allowed to fill with water and were subjected to several freeze-thaw cycles. After discussing with Concrete Industries, Inc., the fabricator of the concrete beams, it was believed that as the water froze within the holes, the front and back faces of the concrete beams expanded outward at twenty-three locations, which caused the beams to micro crack, as shown in Figure 103. The cracks were noted as existing damage; however, it was believed that they would not affect the structural integrity of the system and testing continued.



Figure 103. Concrete Beam Cracks Due to Freeze-Thaw

8.2 Test No. SFH-3

The 21,746-lb (9,864-kg) single-unit truck impacted the RESTORE barrier at a speed of 56.5 mph (90.9 km/h) and an angle of 14.9 degrees. A summary of the test results and sequential

photographs are shown in Figure 104. Additional sequential photographs are shown in Figures 105 and 106. Documentary photographs of the crash test are shown in Figures 107 and 108.

8.3 Weather Conditions

Test no. SFH-3 was conducted on March 13, 2015 at approximately 1:45 p.m. The weather conditions, as per the National Oceanic and Atmospheric Administration (station 14939/LNK), were reported and are shown in Table 15.

Table 15. Weather Conditions, Test No. SFH-3

Temperature	75° F
Humidity	22%
Wind Speed	20 mph
Wind Direction	0° from True North
Sky Conditions	Sunny
Visibility	10 Statute Miles
Pavement Surface	Dry
Previous 3-Day Precipitation	0.00 in.
Previous 7-Day Precipitation	0.50 in.

8.4 Test Description

Initial vehicle impact was to occur 60 in. (1,524 mm) upstream from the joint between barrier nos. 5 and 6, as shown in Figure 109. This location was selected based on recommendation for rigid barrier tests in MASH and verified through LS-DYNA simulation. The actual point of impact was 55.75 in. (1,416 mm) upstream from the joint between barrier nos. 5 and 6, as determined from video analysis. A sequential description of the impact events is contained in Table 16. The vehicle came to rest 270 ft (82.3 m) downstream from the original impact point and 19 ft – 9 in. (6.0 m) laterally behind the system. The vehicle trajectory and final position are shown in Figures 104 and 110.

Table 16. Sequential Description of Impact Events, Test No. SFH-3

TIME (sec)	EVENT
0.000	The left-front bumper contacted barrier no. 5 and began to deform.
0.036	The left fender contacted top rail at barrier no. 5.
0.054	Left-front bumper contacted ACJ between barrier nos. 5 and 6.
0.144	Barrier no. 7 began to deflect backward.
0.186	Vehicle left-front lower box compartment contacted top rail.
0.206	Right-front tire became airborne.
0.320	Left-front fender contacted ACJ between barrier nos. 6 and 7.
0.324	Right-rear tire became airborne.
0.326	Vehicle was parallel to barrier along length of barrier no. 6 with front axle perpendicular to ACJ between barrier nos. 6 and 7. .
0.374	Vehicle left-lower box compartment contacted top rail at upstream end of barrier no. 6.
0.388	Barrier reached maximum deflection.
0.746	Vehicle left-front bumper contacted ground.
0.980	Right-front tire regained contact with ground.
1.068	Right-front tire became airborne.
1.320	Vehicle exited system along barrier no. 7.
1.374	Right-front tire re-gained contact with ground.
1.958	Right-rear tire regained contact with ground.
4.276	Vehicle came to rest 270 ft (82.3 m) downstream from original impact point and 19 ft – 9 in. (6.0 m) laterally behind end of system.

8.5 Barrier Damage

Damage to the barrier was minimal, as shown in Figures 110 through 120. Barrier damage consisted of contact marks and gouging on the front face of the concrete beams, cracking and spalling at the joint connections, contact marks along the top of the concrete beams and along the upper tube assembly, and contact with the rubber posts. The length of the vehicle contact along the barrier was approximately 59 ft – 3 in. (18.1 m), which spanned from 60½ in. (1,537 mm) upstream from the joint between barrier nos. 5 and 6 to 29 in. (737 mm) upstream from the joint between barrier nos. 8 and 9. The majority of the contact marks were found on the front face of the concrete beam starting at the impact point and extending through the end of

barrier no. 6. Additional contact marks were found on the top of the concrete rail and upper tube assembly, due to contact with the cargo box.

The front face of barrier no. 5 had spalling downstream from the point of impact that extended 36 in. (914 mm) longitudinally, 5 in. (127 mm) vertically, and 5 in. (127 mm) laterally located along the bottom of the concrete beam. The front of the concrete barriers were gouged from the impact point through the upstream half of barrier no. 6. The first post upstream from the joint between barrier nos. 5 and 6 had a ¼-in. deep (6-mm) x 1-in. (25-mm) diameter 180 degree circular cut on the front face from contact with the left-front tire lug nuts. The top of barrier nos. 6 and 7 were gouged from contact with the underside of the cargo box. The cargo box contacted the downstream upper tube assembly base plate on barrier no. 6, causing part of the box to snag on the base plate, as shown in Figure 115. Other upper tube assembly connection plates were contacted and gouged along the length of barrier no. 7, as shown in Figure 116. Gouging was present on the top chamfer of barrier no. 8 located 32 in. (813 mm) downstream from the midpoint and extending approximately 59 in. (1,499 mm) downstream.

The joints between barrier nos. 4 and 5 through barrier nos. 8 and 9 were damaged, as shown in Figures 118 through 120. For all of the damaged joints, slight spalling occurred around the exterior face of the ACJ bolt holes. The upstream face of barrier no. 5 cracked between the bottom two ACJ bolt holes extending across the face. The downstream face of barrier no. 5 cracked starting at the non-impact-side, top ACJ bolt hole, and extended inward and upward 10½ and 9 in. (267 and 229 mm), respectively. The upstream face of barrier no. 6 spalled along the bottom, which exposed the rebar around the impact-side lower bolt hole. The concrete cracked and spalled at the downstream end of barrier no. 6 near the ACJ on the impact-side face, exposing the reinforcement near the impact-side top bolt hole. The upstream face of barrier no. 7 spalled extending approximately halfway up the side of the face, exposing approximately 5½ in.

(140 mm) of reinforcement. The downstream face of barrier no. 7 spalled with hairline cracks extending 2 in. (51 mm) up from the bottom impact-side ACJ bolt hole. The upstream and downstream faces of barrier nos. 8 and 9 spalled around the ACJ bolt holes.

The permanent set of the barrier was approximately 1½ in. (38 mm), which was measured in the field at the upstream end of barrier no. 6. The maximum lateral dynamic barrier deflection at the top upstream end of concrete barrier no. 6 and the top of the upper tube assembly at the same location, including barrier rotation backward, were 13.9 in. (353 mm) and 15.1 in. (384 mm), respectively, as determined from high-speed video analysis. Multiple barrier deflections with respect to the maximum deflection times are shown in Table 17. The working width of the system was found to be 60.2 in. (1,529 mm) due to the cargo box extension behind the rail, also determined from high-speed digital video analysis. The concrete beams that were cracked prior to the test did not experience any further cracking.

Table 17. Barrier Deflections at Maximum Deflection Times, Test No. SFH-3

Location At Time	Deflections in. (mm)	
	Concrete Beam	Upper Tube
	0.394 sec	0.388 sec
Upstream Barrier No. 5	7.0 (178)	7.7 (196)
Middle Barrier No. 5	9.3 (236)	11.4 (290)
Downstream Barrier No. 5	13.6 (345)	13.8 (351)
Upstream Barrier No. 6	13.9 (353)	15.1 (384)
Middle Barrier No. 6	11.4 (290)	12.4 (315)
Downstream Barrier No. 6	8.9 (226)	10.0 (254)
Upstream Barrier No. 7	8.2 (208)	9.5 (241)
Middle Barrier No. 7	6.2 (157)	7.6 (193)
Downstream Barrier No. 7	3.2 (81)	5.5 (140)

8.6 Vehicle Damage

The damage to the vehicle was moderate, as shown in Figures 121 through 123. The maximum occupant compartment deformations are listed in Table 18 along with the deformation limits established in MASH for various areas of the occupant compartment. Note that none of the MASH-established deformation limits were violated. Complete occupant compartment and vehicle deformations and the corresponding locations are provided in Appendix C.

The majority of the damage was concentrated on the left-front corner of the vehicle where the impact occurred and the frame under the cargo box. The left fender had multiple cracks and gouges starting at the left headlight and extending back along the fender to the back of the wheel well. The front bumper was separated 3½ in. (89 mm) from the grill and had a kink located 16 in. (406 mm) to the left of center. The left headlight was disengaged, and the left-front tire was deflated. Multiple gouges and dents were found along the left-front tire rim. The left-front U-bolts and centering pin were fractured, and the front axle displaced rearward 12 in. (305 mm) along the leaf spring on the left side. Similarly, the right-front U-bolts were fractured, and the front axle displaced 6 in. (152 mm) along the leaf spring on the right side. The top of the left door separated 2½ in. (64 mm) from the cab. The cargo box had multiple dents along the left-front corner, as well as scrapes extending the length of the box. The left-rear tire was deflated due to a gouge in the sidewall of the tire. A 3-in. (76-mm) wide tear occurred 100 in. (2,540 mm) longitudinally back from the front of the cargo box and 18 in. (457 mm) vertically above the bottom of the box. A steel angle disengaged from the lower left-front corner of the cargo box. The chassis frame twisted and displaced to the left, as shown in Figure 121. All of the additional U-bolts that were added to strengthen the box-frame connection were bent. Both the additional shear plates on the left side were bent at the connection between the frame and the sub-frame. The right-front shear plate was bent at the top, and the right-rear shear plate displaced with the

frame/sub-frame. The gas tank displaced rearward 6 in. (152 mm) and had a 1-in. (25-mm) long dent in the leading edge.

Table 18. Maximum Occupant Compartment Deformations by Location, Test No. SFH-3

LOCATION	MAXIMUM DEFORMATION in. (mm)	MASH-ALLOWABLE DEFORMATION in. (mm)
Wheel Well & Toepan	2 ³ / ₈ (60)	≤ 9 (229)
Floorpan & Transmission Tunnel	2 (51)	≤ 12 (305)
Side Front Panel (in Front of A-Pillar)	² / ₃ (17)	≤ 12 (305)
Side Door (Above Seat)	1 ¹ / ₂ (38)	≤ 9 (229)
Side Door (Below Seat)	1 (25)	≤ 12 (305)
Roof	0 (0)	≤ 4 (102)
Windshield	0 (0)	≤ 3 (76)

8.7 Occupant Risk

Occupant risk values are not required evaluation criteria for test designation no. 4-12. However, the occupant risk values were calculated with the same procedure as the 1100C and 2270P vehicles, for comparison only. The calculated OIVs and maximum 0.010-sec ORAs in both the longitudinal and lateral directions are shown in Table 19. The calculated ASI values are also shown in Table 19. The results of the occupant risk analysis, as determined from the accelerometer data, are summarized in Figure 104. The recorded data from the accelerometers and the rate transducers are shown graphically in Appendix D.

Table 19. Summary of OIV, ORA, and ASI Values, Test No. SFH-3

Evaluation Criteria		Transducer and Location			MASH Limits
		SLICE-1 (Under cargo box)	SLICE-2 (Under cargo box)	DTS (Inside cab)	
OIV ft/s (m/s)	Longitudinal	-8.20 (-2.50)	-8.30 (-2.53)	-5.25 (-1.60)	not required
	Lateral	12.63 (3.85)	13.25 (4.04)	11.68 (3.56)	not required
ORA g's	Longitudinal	-6.65	-6.70	-4.70	not required
	Lateral	9.29	7.82	6.83	not required
MAX. ANGULAR DISPL. deg.	Roll	-39.1	-33.8	-33.0	not required
	Pitch	-11.9	-10.7	5.6	not required
	Yaw	30.6	25.7	23.9	not required
ASI		0.48	0.53	0.56	not required

Note: These values are not required by MASH and reported for comparison

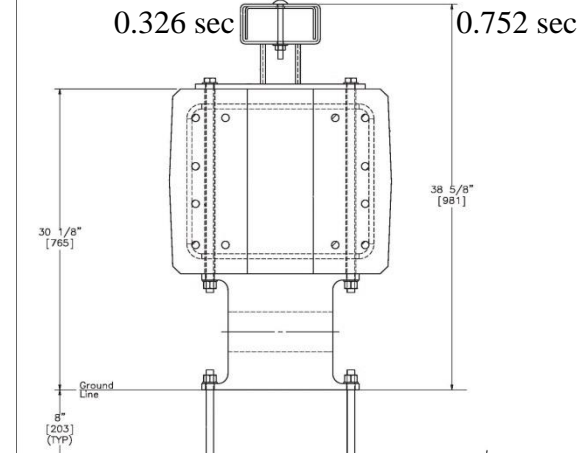
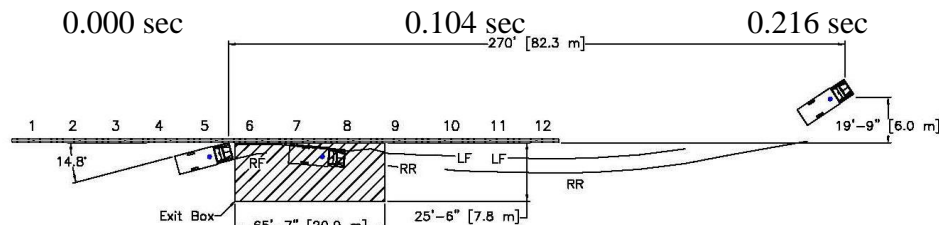

- Test AgencyMwRSF
- Test Number..... SFH-3
- Date 3/13/2015
- MASH Test Designation 4-12
- Test Article..... Low-Maintenance, Energy-Absorbing Concrete Median Barrier
- Total Length 239 ft 11½ in. (73.1 m)
- Key Component – Concrete Barrier Section
 - Length 239½ in. (6,083 mm)
 - Height 18½ in. (470 mm)
 - Depth 21½ in. (546 mm)
- Key Component – Post
 - Height 11½ in. (295 mm)
 - Width 10 in. (254 mm)
 - Depth 15¾ in. (400 mm)
 - Spacing 60 in. (1,524 mm)
- Vehicle Make /Model..... 1998 Ford F-800
- Curb..... 11,180 lb (5,071 kg)
- Test Inertial..... 21,746 lb (9,864 kg)
- Gross Static..... 21,912 lb (9,939 kg)
- Impact Conditions
 - Speed 56.5 mph (90.9 km/h)
 - Angle 14.9 deg
 - Impact Location..... 55.75 in. (1,416 mm) upstream of the joint between barrier nos. 5 and 6
- Exit Conditions
 - Speed 38.7 mph (62.3 km/h)
 - Angle 9 deg
- Exit Box Criterion..... Pass
- Vehicle Stability..... Satisfactory
- Vehicle Stopping Distance 270 ft (82.3 m) downstream of impact
- 19 ft – 9 in. (6.0 m) laterally behind the system
- Vehicle Damage..... Moderate
 - VDS [11] 11-LFQ-4
 - CDC [12] 11-LPEW-9
 - Maximum Interior Deformation 2½ in. (60 mm)

- Impact Severity (IS)..... 154.4 kip-ft (209.3 kJ) > 142 kip-ft (193 kJ) limit from MASH
- Test Article Damage Moderate
- Maximum Test Article Deflections
 - Permanent Set 1½ in. (38 mm)
 - Dynamic of Concrete Beam 13.9 in. (353 mm)
 - Dynamic of Upper Tube Assembly 15.1 in. (384 mm)
 - Working Width..... 60.2 in. (1,529 mm)
- Transducer Data

Evaluation Criteria		Transducer and Location			MASH Limit
		SLICE-1 (Under cargo box)	SLICE-2 (Under cargo box)	DTS (Inside cab)	
OIV ft/s (m/s)	Longitudinal	-8.20 (-2.50)	-8.30 (-2.53)	-5.25 (-1.60)	not required
	Lateral	12.63 (3.85)	13.25 (4.04)	11.68 (3.56)	not required
ORA g's	Longitudinal	-6.65	-6.70	-4.70	not required
	Lateral	9.29	7.82	6.83	not required
MAX ANGULAR DISP. deg.	Roll	-39.1	-33.8	-33.0	not required
	Pitch	-11.9	-10.7	5.6	not required
	Yaw	30.6	25.7	23.9	not required
ASI		0.48	0.53	0.56	not required

147

Figure 104. Summary of Test Results and Sequential Photographs, Test No. SFH-3



0.000 sec



0.092 sec



0.206 sec



0.400 sec



0.980 sec



1.446 sec



0.000 sec



0.042 sec



0.092 sec



0.186 sec



0.324 sec



0.818 sec

Figure 105. Additional Sequential Photographs, Test No. SFH-3



0.000 sec



0.374 sec



0.042 sec



0.474 sec



0.092 sec



0.962 sec

Figure 106. Additional Sequential Photographs, Test No. SFH-3



Figure 107. Documentary Photographs, Test No. SFH-3

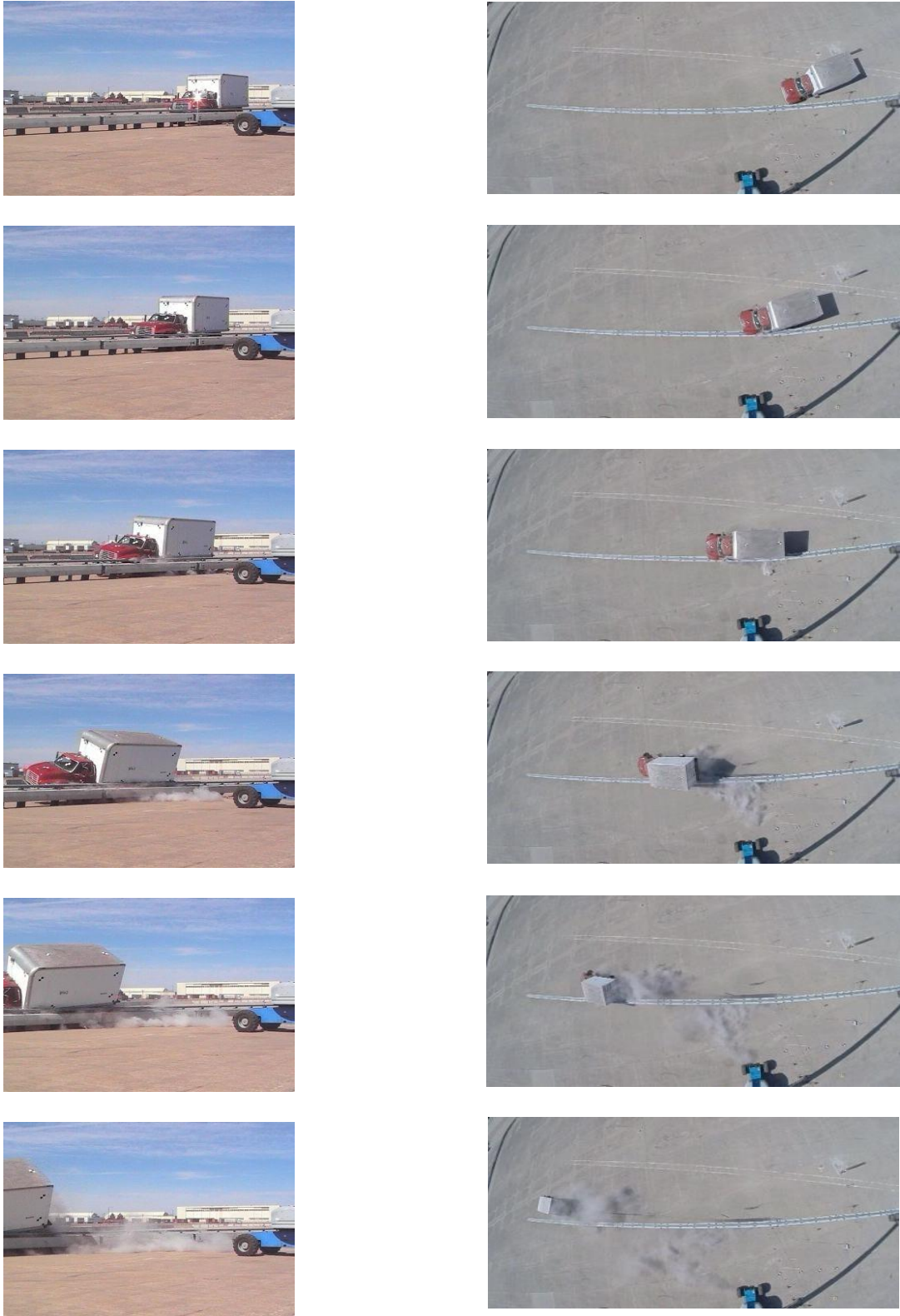

Figure 108. Documentary Photographs, Test No. SFH-3



Figure 109. Impact Location, Test No. SFH-3



Figure 110. Vehicle Final Position and Trajectory Marks, Test No. SFH-3



154



Figure 111. System Damage, Barrier No. 5 and Joint Between Barrier Nos. 5 and 6, Test No. SFH-3



First Post Upstream from Joint between Barrier Nos. 5 and 6



Figure 112. System Damage, Post Contact and Joint between Barrier Nos. 5 and 6, Test No. SFH-3



Figure 113. System Damage, Barrier No. 6, Test No. SFH-3



Figure 114. System Damage, Joint between Barrier Nos. 6 and 7, Test No. SFH-3



Figure 115. System Damage, First Upper Tube Assembly Connection Upstream from Joint between Barrier Nos. 6 and 7, Test No. SFH-3



First Connection Downstream from Joint No. 6/7



Second Connection Downstream from Joint No. 6/7



Third Connection Downstream from Joint No. 6/7



Fourth Connection Downstream from Joint No. 6/7

Figure 116. System Damage, Upper Tube Assembly Connection Damage, Barrier No. 7, Test No. SFH-3



Figure 117. System Damage, Barrier No. 8, Test No. SFH-3



Upstream

Barrier No. 5



Downstream



Upstream

Barrier No. 6



Downstream

Figure 118. System Damage, Joint Damage, Barrier Nos. 5 and 6, Disassembled, Test No. SFH-3



Upstream

Barrier No. 7



Downstream



Upstream

Barrier No. 8



Downstream

Figure 119. System Damage, Joint Damage, Barrier Nos. 7 and 8, Disassembled, Test No. SFH-3



Downstream Barrier No. 4



Upstream Barrier No. 9

Figure 120. System Damage, Joint Damage, Barrier Nos. 4 and 9, Disassembled, Test No. SFH-3



Figure 121. Vehicle Damage, Test No. SFH-3



Left-Front



Right-Front



Left-Rear



Right-Rear

Figure 122. Vehicle Damage, Shear Plate Damage, Test No. SFH-3



Figure 123. Vehicle Damage, Test No. SFH-3

8.8 10000S Peak Lateral Force Calculation

The longitudinal and lateral vehicle accelerations, as measured at the vehicle's c.g., were also processed using a 50-msec moving average. The 50-msec moving average vehicle accelerations were then combined with the uncoupled yaw angle versus time data in order to estimate the vehicular loading applied to the barrier system. From the data analysis, the perpendicular impact force was determined for the RESTORE barrier, as shown in Figure 124. The maximum perpendicular, or lateral, load imparted to the barrier was 94.9 kips (422 kN) and 105.0 kips (467 kN) as determined by the SLICE-1 and SLICE-2, respectively.

8.9 Discussion

The analysis of the test results for test no. SFH-3 showed that the RESTORE barrier adequately contained and redirected the 10000S vehicle with controlled lateral displacements of the barrier. There were no detached elements or fragments which showed potential for penetrating the occupant compartment or for presenting undue hazard to other traffic. Deformations of, or intrusions into, the occupant compartment that could have caused serious injury did not occur. The test vehicle did not penetrate or ride over the barrier and remained upright during and after the collision. Vehicle roll, pitch, and yaw angular displacements, as shown in Appendix D, were deemed acceptable, because they did not adversely influence occupant risk safety criteria or cause rollover. After impact, the vehicle exited the barrier at an angle of 9.0 degrees, and its trajectory did not violate the bounds of the exit box. Therefore, test no. SFH-3, conducted on the RESTORE barrier, was determined to be acceptable according to the MASH safety performance criteria for test designation no. 4-12.

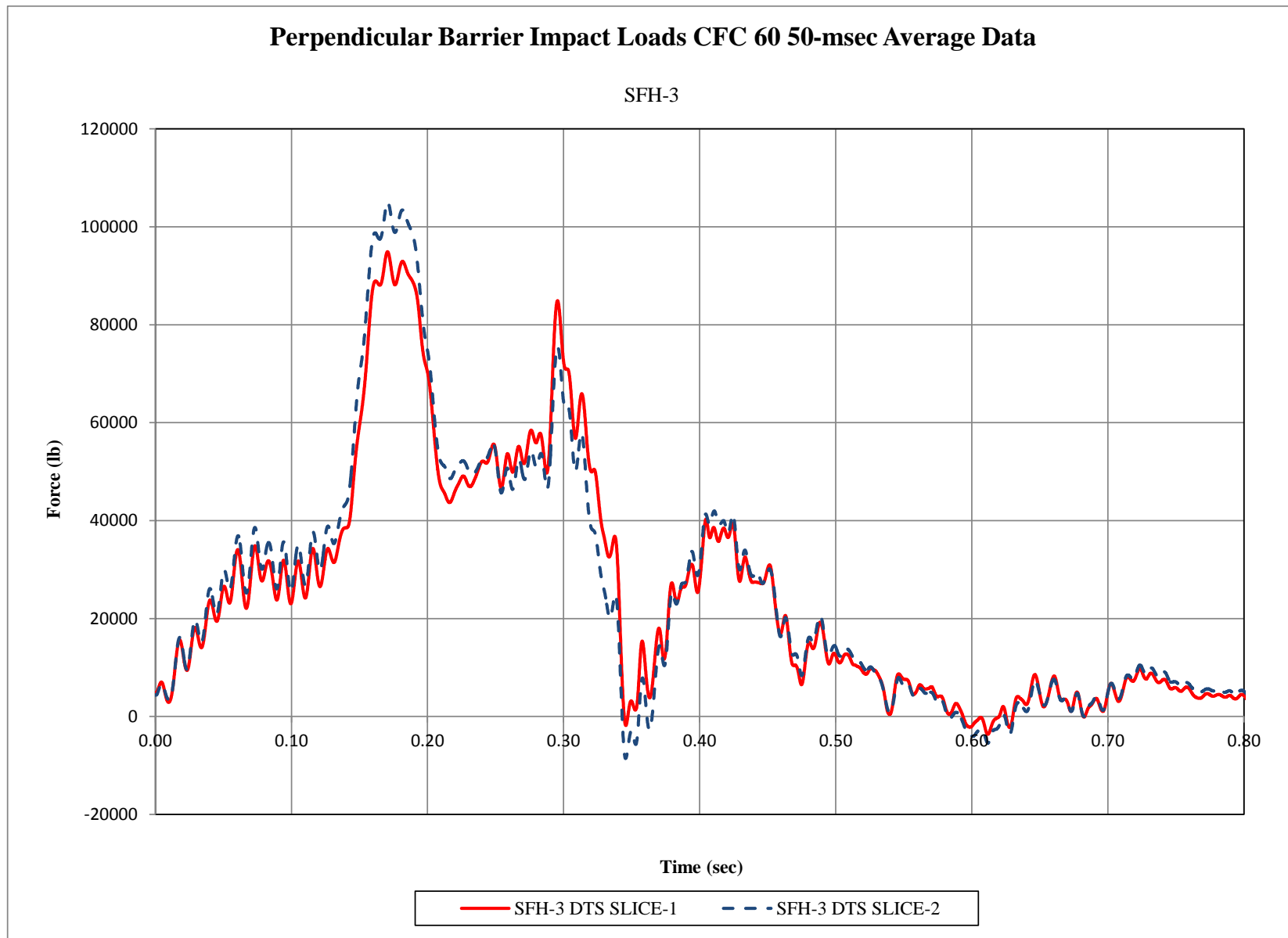

Figure 124. Perpendicular Forces Imparted to the Barrier System, Test No. SFH-3

9 SUMMARY, CONCLUSIONS, AND RECOMMENDATIONS

The objective of the research project was to evaluate the safety performance of a restorable and reusable, energy-absorbing, roadside/median barrier, designated the RESTORE barrier, that was previously developed by Schmidt, et al. [1-3]. The new barrier was designed to fit in current roadside and median footprints and lower lateral accelerations to passenger vehicle occupants during impact events as compared to crashes with rigid concrete barriers. The RESTORE barrier was subjected to three full-scale crash tests and evaluated according to the TL-4 impact safety standards provided in MASH. The safety performance criteria is summarized in Table 20.

The system installation for test nos. SFH-1 through SFH-3 was 239 ft – 11½ in. long (73.1 m) with a nominal height of 38⁵/₈ in. (981 mm). In test no. SFH-1, the 5,021- lb (2,277-kg) pickup truck impacted the system at an angle of 24.8 degrees and a speed of 63.4 mph (102.1 km/h). The vehicle was contained and redirected, and all occupant risk values were within MASH limits. When compared to two similar impacts with rigid barriers according to MASH test designation no. 4-11 tests, the peak lateral accelerations were reduced by up to 47 percent. Similarly, the peak lateral barrier force in test no. SFH-1 was 58 and 62 kip (258 and 278 kN) as determined from the two accelerometers, which is a reduction of up to 38 percent when compared to the similar tests. The lateral and longitudinal OIV values were also reduced.

After test no. SFH-1, the concrete joint directly downstream from the point of impact spalled between the front and back ACJ hardware components. Hairline cracks and gouges were also found on the concrete beams near impact. The dynamic lateral barrier deflection was 11.2 in. (284 mm), and the barrier may have had up to ⁷/₈ in. (22 mm) of permanent displacement, although this was not measured in the field until after the joint was disassembled. The system

damage should not affect the structural capacity of the system, and test no. SFH-1 was deemed acceptable according to MASH test designation no. 4-11.

The barrier in test no. SFH-2 was the same barrier as that used in test no. SFH-1, without replacing any of the hardware or components. In test no. SFH-2, the 2,406-lb (1,091-kg) sedan impacted the system at an angle of 24.8 degrees and a speed of 64.3 mph (103.5 km/h). The vehicle was contained and redirected, and all occupant risk values were within MASH limits. When compared to two similar impacts with rigid barriers according to MASH test designation no. 4-10 tests, the peak lateral acceleration and peak lateral barrier force were reduced by up to 23 percent. The lateral OIV values were reduced by up to 31 percent when compared to similar impacts, but the longitudinal OIV values did not change. However, all occupant risk values were well below MASH limits, and the lateral accelerations were reduced.

During the impact, the concrete beam deflected, which exposed the bottom of the rubber posts. The left-front tire deflated, and the wheel rim cut the bottom of the first two posts downstream from the point of impact. Therefore, the barrier did not fully restore to its original position. The permanent set was approximately 1¾ in. (44 mm), and dynamic deflection was 7.3 in. (185 mm). The concrete beams were also gouged and scraped. The system damage sustained during test no. SFH-2 should not affect the structural capacity of the system, and test no. SFH-2 was deemed acceptable according to MASH test designation no. 4-10.

The barrier in test no. SFH-3 was the same barrier as that used in test nos. SFH-1 and SFH-2, with the exception of replacing the threaded rods connecting the upper tube assembly, concrete rail, and rubber posts with bolts. In test no. SFH-3, the 21,746-lb (9,864-kg) single-unit truck impacted the system at an angle of 14.9 degrees and a speed of 56.5 mph (90.9 km/h). The maximum perpendicular, or lateral, load imparted to the barrier was up to a maximum of 105.0

kins (467 kN), as determined by the SLICE-2. The vehicle was successfully contained and redirected.

After test no. SFH-3, five joints experienced varying levels of damage including concrete cracking and spalling between the front and back ACJ hardware components. The concrete spalled and was gouged on the front face of barrier nos. 5 and 6. The top of the concrete beams were gouged from contact with the cargo box from barrier no. 5 through barrier no. 8. Additionally, the first post downstream from the point of impact had a 1-in. (25-mm) diameter semi-circular cut from impact with one of the left-front tire's lugnuts. The concrete beams dynamically deflected 13.9 in. (353 mm), and the barrier had approximately 1½ in. (38 mm) of permanent displacement. The working width was determined to be 60.2 in. (1,529 mm) as determined from video analysis. The system damage should not affect the structural capacity of the system, and test no. SFH-3 was deemed acceptable according to MASH test designation no. 4-12.

The bolts that connected the upper tube assembly, concrete beams, and posts that were utilized in test no. SFH-3 are recommended in lieu of the threaded rods that were utilized in test nos. SFH-1 and SFH-2. The bolt heads will reduce the profile on top of the concrete beams that vehicles could potentially snag on.

The original design criteria for the barrier included: (1) MASH Test Level 4 performance; (2) a 30 percent reduction in lateral acceleration; (3) a maximum of a 36-in. (914-mm) barrier width; and (4) minimized construction and maintenance cost [1-3]. The system has passed all of the required tests to provide acceptable safety performance according to MASH TL-4 safety performance criteria. In test no. SFH-1, the peak lateral acceleration was reduced by 43 percent. The lateral OIV and ORA values were also reduced by up to 29 and 28 percent, respectively. In test no. SFH-2, the peak lateral acceleration was reduced by up to 21 percent and

the lateral OIV was reduced by up to 31 percent. However, lateral ORA was reduced by up to 11 percent. Still, the barrier provided significant reductions in occupant risk measures.

Up to 10 in. (254 mm) of barrier deflection was estimated to be necessary for a 30 percent reduction in peak lateral acceleration for 2270P pickup truck impacts [1]. In test no. SFH-1, the barrier dynamically deflected 11.2 in. (284 mm), but peak lateral acceleration was up to 47 percent lower than a similar impact into a rigid barrier. So, the initial estimates were fairly accurate.

The barrier width was 22¼ in. (565 mm), which is less than the maximum desired width of 36 in. (914 mm). The initial cost for the new system was recommended to be less than 200 dollars per linear foot. With only a small prototype system, the cost was more than desired. However, the initial cost of the RESTORE barrier will decrease for longer installations. The installation time, and cost associated with installation time, is anticipated to be much less than a typical slipformed, rigid concrete barrier. Since the RESTORE barrier is constructed of prefabricated components, lane closures and work-zone areas are only needed during installation. However, a slipformed concrete barrier needs longer lane closure time and work-zone area, so that the concrete can cure properly.

The system was to have virtually zero maintenance costs due to impacts with passenger vehicles. However, some damage occurred in all three crash tests. Prior to test no. SFH-3, water accumulated in the bolt holes in the concrete beams. The water froze in the bolt holes, which caused cracking in the beams. The cracking was not believed to reduce the structural strength of the barrier. However, modification of the bolt hole to post connection is necessary to prevent water accumulation in the system and maintenance. Drainage holes are also recommended to be added to the base of the skids to prevent water from accumulating inside the pipe.

Due to the concrete spalling that occurred in all three crash tests, and the post damage in test no. SFH-2, refinements are recommended to eliminate damage and the need for maintenance. The concrete beam may be strengthened near the ends to minimize the spalling and cracking that occurred at the joints in test nos. SFH-1 and SFH-3. The concrete beam surface gouging may also be minimized by changing the concrete mix, by increasing the concrete density, or by adding reinforcing fibers. However, completely eliminating concrete gouges is not likely, as this is common in all concrete barriers. There are several possible modifications to prevent significant wheel contact with the rubber posts, including: reducing the clear opening below the concrete beam; widening the concrete beams; and modifying the posts.

Further research is recommended to transition and terminate the RESTORE longitudinal barrier. The barrier system was tested with no upstream or downstream anchorages to evaluate the maximum deflection and backward rotation that could be experienced by the barrier, similar to a long installation when the termination is far from the impact region. However, the upstream and downstream ends of the RESTORE barrier should be transitioned into another barrier system, such as a rigid concrete barrier or buttress. The rigid concrete barrier or buttress could then be protected with a crash cushion or transitioned to a different longitudinal barrier. The effects of a transition and of constraining the ends of the RESTORE barrier will be evaluated to determine any limitations on barrier installation length in the continuing phases of this research effort.

Table 20. Summary of Safety Performance Evaluation Results

Evaluation Factors	Evaluation Criteria	Test No. SFH-1	Test No. SFH-2	Test No. SFH-3		
Structural Adequacy	A. Test article should contain and redirect the vehicle or bring the vehicle to a controlled stop; the vehicle should not penetrate, underride, or override the installation although controlled lateral deflection of the test article is acceptable.	S	S	S		
Occupant Risk	D. Detached elements, fragments or other debris from the test article should not penetrate or show potential for penetrating the occupant compartment, or present an undue hazard to other traffic, pedestrians, or personnel in a work zone. Deformations of, or intrusions into, the occupant compartment should not exceed limits set forth in Section 5.3 and Appendix E of MASH.	S	S	S		
	F. The vehicle should remain upright during and after collision. The maximum roll and pitch angles are not to exceed 75 degrees.	S	S	S		
	G. It is preferable, although not essential, that the vehicle remain upright during and after collision.	NA	NA	S		
	H. Occupant Impact Velocity (OIV) (see Appendix A, Section A5.3 of MASH for calculation procedure) should satisfy the following limits:	S	S	NA		
	Occupant Impact Velocity Limits					
	Component				Preferred	Maximum
Longitudinal and Lateral	30 ft/s (9.1 m/s)	40 ft/s (12.2 m/s)				
I. The Occupant Ridedown Acceleration (ORA) (see Appendix A, Section A5.3 of MASH for calculation procedure) should satisfy the following limits:	S	S	NA			
Occupant Ridedown Acceleration Limits						
Component				Preferred	Maximum	
Longitudinal and Lateral	15.0 g's	20.49 g's				
MASH Test Designation		4-11	4-10	4-12		
Pass/Fail		Pass	Pass	Pass		

S – Satisfactory U – Unsatisfactory NA - Not Applicable

10 REFERENCES

1. Schmidt, J.D., Faller, R.K., Sicking, D.L., Reid, J.D., Lechtenberg, K.A., Bielenberg, R.W., Rosenbaugh, S.K., and Holloway, J.C., *Development of a New Energy-Absorbing Roadside/Median Barrier System with Restorable Elastomer Cartridges*, Final Report to the Nebraska Department of Roads and the Federal Highway Administration – Nebraska Division, MwRSF Research Report No. TRP-03-281-13, Midwest Roadside Safety Facility, University of Nebraska-Lincoln, Lincoln, Nebraska, July 16, 2013.
2. Schmidt, J.D., Schmidt, T.L., Faller, R.K., Sicking, D.L., Reid, J.D., Lechtenberg, K.A., Bielenberg, R.W., Rosenbaugh, S.K., and Holloway, J.C., *Evaluation of Energy Absorbers for Use in a Roadside/Median Barrier*, Final Report to the Nebraska Department of Roads and the Federal Highway Administration – Nebraska Division, MwRSF Research Report No. TRP-03-280-14, Midwest Roadside Safety Facility, University of Nebraska-Lincoln, Lincoln, Nebraska, February 6, 2014.
3. Schmidt, J.D., Rosenbaugh, S.K., Faller, R.K., Bielenberg, R.W., Reid, J.D., Holloway, J.C., Lechtenberg, K.A., and Kohtz, J.E., *Design and Evaluation of an Energy-Absorbing, Reusable, Roadside/Median Barrier, Phase 3*, Draft Report to the Nebraska Department of Roads and the Federal Highway Administration, MwRSF Research Report No. TRP-03-317-15, Midwest Roadside Safety Facility, University of Nebraska-Lincoln, Lincoln, Nebraska, February 10, 2015.
4. *Manual for Assessing Safety Hardware (MASH)*, American Association of State Highway and Transportation Officials (AASHTO), Washington, D.C., 2009.
5. Hinch, J., Yang, T.L., and Owings, R., *Guidance Systems for Vehicle Testing*, ENSCO, Inc., Springfield, Virginia, 1986.
6. *Center of Gravity Test Code - SAE J874 March 1981*, SAE Handbook Vol. 4, Society of Automotive Engineers, Inc., Warrendale, Pennsylvania, 1986.
7. MacInnis, D., Cliff, W., and Ising, K., *A Comparison of the Moment of Inertia Estimation Techniques for Vehicle Dynamics Simulation*, SAE Technical Paper Series – 970951, Society of Automotive Engineers, Inc., Warrendale, Pennsylvania, 1997.
8. Taborck, J.J., *Mechanics of Vehicle – 7*, Machine Design Journal, May 30, 1957.
9. Ford Motor Company. *2005 Body Builder Layout Book, Truck Body Builder Advisory Service, Appendix-Design Recommendations, Second Unit Body Mounting*. Ford Motor Company, 2005, pp. 186-194. [<https://www.fleet.ford.com/truckbbas/topics/2005/subm.html>]
10. Society of Automotive Engineers (SAE), *Instrumentation for Impact Test – Part 1 – Electronic Instrumentation*, SAE J211/1 MAR95, New York City, NY, July, 2007.
11. *Vehicle Damage Scale for Traffic Investigators*, Second Edition, Technical Bulletin No. 1, Traffic Accident Data (TAD) Project, National Safety Council, Chicago, Illinois, 1971.

12. *Collision Deformation Classification – Recommended Practice J224 March 1980*, Handbook Volume 4, Society of Automotive Engineers (SAE), Warrendale, Pennsylvania, 1985.
13. Williams, W.F., Bligh, R.P., and Menges, W.L., *MASH Test 4-11 of the TxDOT Single Slope Bridge Rail (Type SSTR) on Pan-Formed Bridge Deck*, Final Report to the Texas Department of Transportation, Report No. FHWA/TX-11/9-1002-3, Texas Transportation Institute, Texas A&M University, College Station, Texas, March 2011.
14. Schmidt, J.D., Faller, R.K., Lechtenberg, K.A., Sicking, D.L., and Reid, J.D., *Development and Testing of a New Vertical-Faced Temporary Concrete Barrier for use on Composite Panel Bridge Decks*, Final Report to the Kansas Department of Transportation, MwRSF Research Report No. TRP-03-220-09, Midwest Roadside Safety Facility, University of Nebraska-Lincoln, Lincoln, Nebraska, October 13, 2009.
15. Bligh, R.P., Arrington, D.R., Sheikh, N.M., Silvestri, C., and Menges, W.L., *Development of a MASH TL-4 Median Barrier Gate*, Final Report to the Texas Department of Transportation, Report No. FHWA/TX-11/9-1002-2, Texas A&M University, College Station, Texas, Texas Transportation Institute, June 2011.
16. Polivka, K.A., Faller, R.K., Sicking, D.L., Rohde, J.R., Bielenberg, R.W., Reid, J.D., and Coon, B.A., *Performance Evaluation of the Permanent New Jersey Safety Shape Barrier – Update to NCHRP 350 Test No. 4-10 (2214NJ-1)*, Final Report to the National Cooperative Highway Research Program, MwRSF Research Report No. TRP-03-177-06, Midwest Roadside Safety Facility, University of Nebraska-Lincoln, Lincoln, Nebraska, October 13, 2006.

11 APPENDICES

Appendix A. Material Specifications

Table A-1. Bill of Materials, Test Nos. SFH-1 and SFH-2

Item	Qty	Description	Material Specification	Reference
a1	12	Lightweight Concrete Beam	min f'c=5 ksi [34.5 MPa], density=110 pcf	No designation but the CERTS were provided
a2	48	Morse E46496 Post	ASTM D2000	Part No. EF6496 Order# 54803 and 52730
a3	22	6"x6"x1/2" [152x152x13], 17" [432] Long L-Bracket	A992 Galvanized	H# L92705
a4	88	5"x5"x3/8" [127x127x10] Gusset Plate	A572 Grade 50 Galvanized	H# A3V3389
b1	192	3/4" [19] Dia., 22" [559] Long Threaded Rod	A193 Grade B7 Galvanized	L # 213B201-29
b2	192	3/4" [19] Dia., 10" [254] Long Threaded Rod	A193 Grade B7 Galvanized	L # 213B201-29
b3	576	3/4" [19] Dia. UNC Heavy Hex Nut	ASTM A194 Grade 2H Galv.	L# 320062A H# DL12104577
b4	576	3/4" [19] Dia. Flat Washer	ASTM F436 Galv.	L# C7602D H# 326352
b5	88	1" [25] Dia. UNC, 11 1/2" [292] Long Hex Head Bolt	Bolt ASTM A325 Galv. (FBX24b)	L# 36046 H# 133782
b6	176	3"x3"x1/4" [76x76x6] Square Washer	A572 Grade 50 Galvanized	L# 2031289
b7	88	1" [25] Nut	Nut ASTM A563 A Galv. (FBX24b)	L# 315776B H# DL12104575
c1	336	1/2" [13] Dia., 77" [1956] Long Bent Rebar	A615 Grade 60	H# 566673
c2	96	1/2" [13] Dia., 49" [1245] Long Bent Rebar	A615 Grade 60	H# 566673
c3	144	3/4" [19] Dia., 231" [5867] Long Rebar	A615 Grade 60	H# 62133268/02
c4	96	3/4" [19] Dia., 63" [1600] Long Bent Rebar	A615 Grade 60	H# 62133268/02
c5	72	3/4" [19] Dia., 69" [1753] Long Bent Rebar	A615 Grade 60	H# 62133268/02
d1	48	17"x8"x1/2" [432x203x13] Anchor Plate	ASTM A572 Grade 50 Galvanized	H# 248447/48
d2	48	4"x4"x1/4" [102x102x6], 4" [102] Long Tube	A500 Grade B Galvanized	H# C66401
d3	11	8"x4"x1/4" [203x102x6], 239 1/2" [6083] Long Tube	A500 Grade B Galvanized	H# GA7242 and H# NC7160
d4	2	8"x4"x1/4" [203x102x6], 119 1/2" [3035] Long End Tube	A500 Grade B Galvanized	H# GA7242 and H# NC7160
d5	12	12 3/4"x6 1/2"x3/16" [324x165x5] Bent Plate	ASTM A572 Grade 50 Galvanized	H# A3F10
d6	24	1/2" [13] Dia., 5 1/2" [140] Long Dome (Round) Head Bolt	Bolt ASTM A307 Grade A Galvanized	L# 36048 H# 2027007
d7	24	1/2" [13] Nut	Nut A563A Galvanized	L# 325254B H# NF12104365
d8	24	1/2" [13] Dia. Flat Washer	ASTM F844 Galvanized	Supplier Bag # 109047
d9	-	Epoxy	HILTI HIT-RE500	Tech Data is provided

Table A-1 Continued. Bill of Materials, Test Nos. SFH-1 and SFH-2

Item	Qty	Description	Material Specification	Reference
e1	24	6 1/2" [165] Dia., 3/8" [10] Thick, 19" [483] Long Steel Pipe	AISI 1026	R# 14-0519 H# NLK1474573
e2	24	16 9/16"x10"x1/4" [421x254x6] Base Plate	ASTM A572 Grade 50 Steel	R# 14-0559 H# A31030
e3	48	3 1/2"x10 3/8"x1/2" [89x264x13] Plate Gusset	ASTM A572 Grade 50 Steel	R# 14-0559 H# A3D099
e4	24	12"x12"x3/8" [305x305x10] Top Plate	ASTM A572 Grade 50 Steel	R# 14-0559 H# A3V3389
e5	24	12"x12"x1/2" [305x305x13] EPDM Rubber Sheet	Minimum 50 durometer	Rubber Material Invoice

Table A-2. Bill of Materials, Test Nos. SFH-3

Item	Qty	Description	Material Specification	Reference
a1	12	Lightweight Concrete Rail	min f _c =5 ksi [34.5 MPa], density=110 pcf	No designation but the CERTS were provided SMT
a2	48	Morse E46496 Shear Fender	ASTM D2000	Part No. EF6496 Order# 54803 and 52730
a3	22	6"x6"x1/2" [152x152x13], 17" [432] Long L-Bracket	A992 Galvanized	H# L92705
a4	88	5"x5"x3/8" [127x127x10] Gusset Plate	A572 Grade 50 Galvanized	H# A3V3389
b1	192	3/4" [19] Dia., 21" [559] Long Hex Bolt	Grade 5 Galvanized	KD Fastener's COC says Grade 5
b2	192	3/4" [19] Dia., 10" [254] Long Threaded Rod	A193 Grade B7 Galvanized	H# E11400347 L# 213B249-13
b3	384	3/4" [19] Dia. UNC Heavy Hex Nut	ASTM A194 Grade 2H Galv.	L# 320062A H# DL12104577
b4	576	3/4" [19] Dia. Flat Washer	ASTM F436 Galv.	L# C7602D H# 326352
b5	88	1" [25] Dia. UNC, 11 1/2" [292] Long Hex Head Bolt	Bolt ASTM A325 Galv. (FBX24b)	L# 36046 H# 133782
b6	176	3"x3"x1/4" [76x76x6] Square Washer	A572 Grade 50 Galvanized	L# 2031289
b7	88	1" [25] Nut	Nut ASTM A563 A Galv. (FBX24b)	L# 315776B H# DL12104575
c1	336	1/2" [13] Dia., 77" [1956] Long Bent Rebar	A615 Grade 60	H# 566673
c2	96	1/2" [13] Dia., 49" [1245] Long Bent Rebar	A615 Grade 60	H# 566673
c3	144	3/4" [19] Dia., 231" [5867] Long Rebar	A615 Grade 60	H# 62133268/02
c4	96	3/4" [19] Dia., 63" [1600] Long Bent Rebar	A615 Grade 60	H# 62133268/02
c5	72	3/4" [19] Dia., 69" [1753] Long Bent Rebar	A615 Grade 60	H# 62133268/02
d1	48	17"x8"x1/2" [431x203x13] Anchor Plate	ASTM A572 Grade 50 Galvanized	H# 248447/48
d2	48	4"x4"x1/4" [102x102x6], 4" [102] Long Tube	A500 Grade B Galvanized	H# C66401
d3	11	8"x4"x1/4" [203x102x6], 239 1/2" [6083] Long Tube	A500 Grade B Galvanized	H# GA7242 and H# NC7160
d4	2	8"x4"x1/4" [203x102x6], 119 1/2" [3035] Long End Tube	A500 Grade B Galvanized	H# GA7242 and H# NC7160
d5	12	12 3/4"x6 1/2"x3/16" [324x165x5] Bent Plate	ASTM A572 Grade 50 Galvanized	H# A3F10
d6	24	1/2" [13] Dia., 5 1/2" [140] Long Dome (Round) Head Bolt	Bolt ASTM A307 Grade A Galvanized	L# 36048 H# 2027007
d7	24	1/2" [13] Dia. Flat Washer	ASTM F844 Galvanized	Plastic bag labeled 109047
d8	24	1/2" [13] Nut	Nut A563A Galvanized	L# 325254B H# NF12104365
d9	-	Epoxy	HILTI HIT-RE500	Tech Data is provided

Table A-2 Continued. Bill of Materials, Test Nos. SFH-3

Item	Qty	Description	Material Specification	Reference
e1	24	6 1/2" [165] Dia., 3/8" [10] Thick, 19" [483] Long Steel Pipe	ASTM 513 Grade: 1026	H# NLK1474573
e2	24	16 9/16"x10"x1/4" [421x254x6] Base Plate	ASTM A572 Grade 50 Steel	H# A3I030
e3	48	3 1/2"x10 3/8"x1/2" [89x264x13] Plate Gusset	ASTM A572 Grade 50 Steel	H# A3D099
e4	24	12"x12"x3/8" [305x305x10] Top Plate	ASTM A572 Grade 50 Steel	H# A3V3389
e5	24	12"x12"x1/2" [305x305x13] EPDM Rubber Sheet	Minimum 50 durometer	Invoice only

Shear Fenders
October 2013

Morse Rubber

CERTIFICATE OF CONFORMANCE

University of Nebraska-Lincoln 10/16/13 EF6496
Company Date Part Number

We hereby certify that all items shipped on our Order No. 54803 &
Shipper No. 61145, against your Purchase Order No. 4500265407
comply with all published requirements and specifications.



John E. Rector
Name

Vice President
Title

Morse Rubber L.L.C.
3588 Main Street, Keokuk, IA 52632
Telephone (319) 524-8430 Telefax (319) 524-7290

Figure A-1. Rubber Post, Test Nos. SFH-1 through SFH-3

Atlas Tube Inc.
5039N County Road 1015
Blytheville, Arkansas, USA
72315
Tel: 870-838-2000
Fax: 870-762-6630



Ref.B/L: 80561702
Date: 09.18.2013
Customer: 179

MATERIAL TEST REPORT

Sold to

Steel & Pipe Supply Compan
PO Box 1688
MANHATTAN KS 66505
USA

Shipped to

Steel & Pipe Supply Compan
310 Smith Road
JONESBURG MO 63351
USA

Material: 2.0x2.0x188x20'0"0(10x5). Material No: 200201882000 Made in: USA
Melted in: USA

Sales order: 848727 Purchase Order: C452000968 Cust Material #: 6520018820

Heat No	C	Mn	P	S	Si	Al	Cu	Cb	Mo	Ni	Cr	V	Ti	B	N
Y67950	0.160	0.480	0.009	0.006	0.019	0.048	0.020	0.001	0.002	0.010	0.040	0.001	0.001	0.000	0.005

Bundle No	PCs	Yield	Tensile	Eln.2in	Certification	CE: 0.25
W002043397	50	064300 Psi	071100 Psi	35 %	ASTM A500-10A GRADE B&C	

Material Note:
Sales Or.Note:

Material: 2.0x2.0x188x20'0"0(10x5). Material No: 200201882000 Made in: USA
Melted in: USA

Sales order: 848727 Purchase Order: C452000968 Cust Material #: 6520018820

Heat No	C	Mn	P	S	Si	Al	Cu	Cb	Mo	Ni	Cr	V	Ti	B	N
Y67950	0.160	0.480	0.009	0.006	0.019	0.048	0.020	0.001	0.002	0.010	0.040	0.001	0.001	0.000	0.005

Bundle No	PCs	Yield	Tensile	Eln.2in	Certification	CE: 0.25
W002043398	50	064300 Psi	071100 Psi	35 %	ASTM A500-10A GRADE B&C	

Material Note:
Sales Or.Note:

Material: 4.0x4.0x250x48'0"0(5x2). Material No: 400402504800 Made in: USA
Melted in: USA

Sales order: 849671 Purchase Order: 45-211043 Cust Material #: 6540025048

Heat No	C	Mn	P	S	Si	Al	Cu	Cb	Mo	Ni	Cr	V	Ti	B	N
C66401	0.210	0.480	0.009	0.001	0.030	0.040	0.110	0.000	0.020	0.050	0.040	0.001	0.001	0.000	0.008

Bundle No	PCs	Yield	Tensile	Eln.2in	Certification	CE: 0.32
M400075272	10	069580 Psi	081590 Psi	25 %	ASTM A500-10A GRADE B&C	

Material Note:
Sales Or.Note:

Marvin Phillips
Marvin Phillips

Authorized by Quality Assurance:
The results reported on this report represent the actual attributes of the material furnished and indicate full compliance with all applicable specification and contract requirements.
CE calculated using the AWS D1.1 method.



Figure A-2. Top Steel Beam Supporting Posts, Test Nos. SFH-1 through SFH-3

20Nov13 15:39 TEST CERTIFICATE No: MAR 100729

INDEPENDENCE TUBE CORPORATION P/O No 4500214923
6226 W. 74TH STREET Rel
CHICAGO, IL 60638 S/O No MAR 250654-001
Tel: 708-496-0380 Fax: 708-563-1950 B/L No MAR 146104-001 Shp 14Nov13
Inv No Inv

Sold To: (5017) Ship To: (1)
STEEL & PIPE SUPPLY STEEL & PIPE SUPPLY
401 NEW CENTURY PARKWAY 401 NEW CENTURY PKWY
KANSAS CITY WHSE. NEW CENTURY, KS 66031
NEW CENTURY, KS 66031

Tel: 913-768-4333 Fax: 913 768-6683

CERTIFICATE-of ANALYSIS and TESTS Cert: No: MAR 100729
12Nov13

Part No 0010
TUBING A500 GRADE B(C) Pcs Wgt
8" X 4" X 1/4" X 20' 16 6,086
Heat Number Tag No Pcs Wgt
GA7242 762417 8 3,043
YLD=53160/TEN=69050/ELG=38.1
GA7242 762418 8 3,043

Heat Number *** Chemical Analysis ***
GA7242 C=0.2300 Mn=0.7900 P=0.0120 S=0.0060 Si=0.0140 Al=0.0400
Cu=0.0200 Cr=0.0400 Mo=0.0020 V=0.0010 Ni=0.0100

WE PROUDLY MANUFACTURE ALL OF OUR HSS IN THE USA.
INDEPENDENCE TUBE PRODUCT IS MANUFACTURED, TESTED,
AND INSPECTED IN ACCORDANCE WITH ASTM STANDARDS.

CURRENT STANDARDS:
.....A500/A500M-10a
.....A513-07
.....A252-98 (2002)
.....A847/A847M-11

Page: 1 Last

Figure A-3. Top Steel Beam, Test Nos. SFH-1 through SFH-3



СЕРТИФИКАТ КАЧЕСТВА И КОЛИЧЕСТВА № 76865 29.09.2011
CERTIFICATE OF QUALITY AND QUANTITY

Система качества сертифицирована на соответствие требованиям МС ИСО 9001-2008
Quality system was certified for compliance with IS ISO 9001-2008

ОАО "СЕВЕРСТАЛЬ" ЧЕРЕПОВЕЦ РОССИЯ, 162600, ул. МИРА
JSC "SEVERSTAL" CHEREPOVETS RUSSIA, 162600, 30, MIRA str

Свидетельство о приемочных испытаниях
Inspection certificate EN10204/3.1

Продавец/Производитель
Seller/Manufacturer

ОАО "СЕВЕРСТАЛЬ", РОССИЯ
JSC "SEVERSTAL", RUSSIA

Грузополучатель, адрес
Consignee, Address

"СЕВЕРСТАЛЬ ЭКСПОРТ ГМБХ"
"SEVERSTAL EXPORT GMBH"
ШТАНШТАДТ ФИШЕРГАССЕ 3
STANSSTAD FISCHERGASSE 3

Заказ № 540014/519C Поз. № 2
Order № Poz №

Контракт № 756/00186217-80112
Contract №

Спецификация № 98650
Specification №

Фондодержатель 3851/00/000

Страна назначения 840 СОЕДИНЕННЫЕ ШТАТЫ
Country of destination UNITED STATES

Разрешение на вывоз № НЕ ЛИЦЕНЗИРУЕТСЯ
Export Licence № NO SUBJECT OF LICENCE

Вагон N 67263368
Freight Car No

Лист № 1 Листов № 2
Sheet Sheets

Наименование и код товара Description and Code of Goods	ОКПО NAVS	Стандарт Standard	Вид груз. мест Type of Packages	МН мест Package No.
ЛИСТОВАЯ ГОРЯЧЕКАТАНАЯ СТАЛЬ HOT-ROLLED STEEL PLATES	97100	ASTM A572/A572M-07	ЛИСТЫ PLATES	12
	402413240	ASTM A572/A572M-07		
		ASTM A6/A6M-10		

№ Item	Номера плавок Nos. of Heats	Номера партий Nos. of	Марка Grades	Категория Category	Размеры, мм Dimensions, mm	Кол-во штук Qty	Масса теоретич. Mass calculated, кг / фунт	Брутто Gross	Нетто Net
1	248448	8101	50(345)	Type 2	12.70x2438x6096 0.5x98x240	6	9264 20424	9264	20424
2	248447	8038	50(345)	Type 2	12.70x2438x6096 0.5x98x240	6	9264 20424	9264	20424
						12	18528	18528	
							40848	40848	

СТАЛЬ ЭСПП. НЕПРЕРЫВНАЯ РАЗЛИВКА. Состояние поставки: ГОРЯЧЕКАТАНАЯ ПЛАВКА ВАКУУМИРОВАНА
CONTINUOUS CASTING E.A.F. Delivery condition: AS-ROLLED THE HEATS IS VACUUM TREATED

Кромки ОБРЕЗНАЯ
Edge SE

ВЕС ЛИСТА РАСЧЕТНЫЙ, КГ(ФУНТ)(WEIGHT CALCULATION PLATE, KG(LB)) 1544(3404)

ВЕС МЕТАЛЛОПРОКАТА ОПРЕДЕЛЕН РАСЧЕТНЫМ ПУТЕМ - STEEL FLAT PRODUCT WEIGHT HAS BEEN CALCULATED.

Указанный в настоящем ДОКУМЕНТЕ товар соответствует по качеству действующим стандартам, техническим условиям и спецификации и может быть отгружен на экспорт. It is hereby certified that the quality of goods mentioned in this shipping DOCUMENT is in conformity with standards and specifications, and the goods may be exported.

Показатели качества товара Quality Characteristics of Goods

№ п/п Item No.	C% *100	Si% *100	Mn% *100	P% *1000	S% *1000	Cr% *100	Ni% *100	Cu% *100	Al% *100	MO% *100	V% *1000	Nb% *1000
1	19	30	104	17	7	9	8	25	3	0.6	2.2	2
2	19	36	105	12	14	9	8	22	3.2	0.7	2.3	2

СЖС Восток Трд № 24

Figure A-4. Upper Steel Tube Mounting Plate, Test Nos. SFH-1 through SFH-3

CERTIFIED TEST REPORT

C7602
10/09/13

*HORIZON STEEL
50390 UTICA DRIVE
SHELBY TWP., MICH. 48315
800-575-9914

TO: PRESTIGE STAMPING
23513 GROESBECK HWY.
WARREN, MI 48090

SHIP TO: PRESTIGE STAMPING, INC.
23513 GROESBECK HIGHWAY
WARREN, MI. 48090
586-773-2700

SIZE: .122 MIN X 3.50 X COIL
GRADE: HRPO F436 GRADE
MELTED & MFG IN USA

B/L Date 10/09/13 Bill/Ladng# 117811 Sales Ord# 810286 01
Cust. P/O#: 22153-1 Part No.: Z25500122 FOR PT# P1480H00

Tag# 746017 01 Heat# 326352 MasterTag# 234034 01
C : .251 Mn: 1.31 P : .010 S : .001 Al: .042 Si: .204
Ni: .010 Cb: .001 Mo: .003 Cu: .014 Va: .001 Cr: .249
Ca: .002 N : .006 Ti: .002
Rock: 89 Olsn: 550

Tag# 746018 01 Heat# 326352 MasterTag# 234034 01
C : .251 Mn: 1.31 P : .010 S : .001 Al: .042 Si: .204
Ni: .010 Cb: .001 Mo: .003 Cu: .014 Va: .001 Cr: .249
Ca: .002 N : .006 Ti: .002
Rock: 89 Olsn: 550

Tag# 746019 01 Heat# 326352 MasterTag# 234034 01
C : .251 Mn: 1.31 P : .010 S : .001 Al: .042 Si: .204
Ni: .010 Cb: .001 Mo: .003 Cu: .014 Va: .001 Cr: .249
Ca: .002 N : .006 Ti: .002
Rock: 89 Olsn: 550

Tag# 746035 01 Heat# 326352 MasterTag# 234034 01
C : .251 Mn: 1.31 P : .010 S : .001 Al: .042 Si: .204
Ni: .010 Cb: .001 Mo: .003 Cu: .014 Va: .001 Cr: .249
Ca: .002 N : .006 Ti: .002
Rock: 89 Olsn: 550

Tag# 746037 01 Heat# 326352 MasterTag# 234034 01
C : .251 Mn: 1.31 P : .010 S : .001 Al: .042 Si: .204
Ni: .010 Cb: .001 Mo: .003 Cu: .014 Va: .001 Cr: .249
Ca: .002 N : .006 Ti: .002
Rock: 89 Olsn: 550

Tag# 746038 01 Heat# 326352 MasterTag# 234034 01
C : .251 Mn: 1.31 P : .010 S : .001 Al: .042 Si: .204
Ni: .010 Cb: .001 Mo: .003 Cu: .014 Va: .001 Cr: .249
Ca: .002 N : .006 Ti: .002
Rock: 89 Olsn: 550

WE HEREBY CERTIFY THE ABOVE IS CORRECT AS CONTAINED IN THE RECORDS OF THE
Continued...

Figure A-5. 3/4-in. (19-mm) Diameter Flat Washer, Test Nos. SFH-1 through SFH-3

CERTIFICATE OF INSPECTION

Purchaser: PFC Date: 2013-11-3
P.O.NO: PO 13062519 ISO NO: 15/11Q5220R11
INV NO: 98017RB133167B Expire: 2014-03-22
Manufacturer: ZHEJIANG GUORUI CO.,LTD.
Address: No.283 Chengxi North Road,Wuyuan Town,Haiyan Zhejiang_P.R.China
ASTM A193 ALLOY GR.B7 FULL THREAD ROD, "B7" &MFG'S
I.D. STAMPED ON END OF RODS(END TO END,NO
CHAMFERED AT ENDS) CUSTOMER PART NO.: 04170-3212-020
Commodity: MANUFACTURING DATE: 2013.10.3
Size: 3/4-10 X 12FT
Lot NO.: 213B201-29
Ship quantity: 0.125 MPCS MATERIAL: AISI 4140
Finish: PLN

DIMENSIONAL INSPECTION ACCORDING TO ASME B18.31.3-2009

TEST DATE: 2013-09-25 SAMPLED BY:WEIHAIJUN TITLE:QC MANAGER SAMPLING DATE: 2013-09-25

INSPECTION ITEM	SAMPLE SIZE	SPECIFICATION	ACTUAL RESULT	UNIT	ACCEPT	REJECT
Marking	46	B7&CF	OK		46	0
Major Diameter	14	0.7482-0.7353	0.738-0.741	INCH	14	0
Length	14	144.5-143.5	144.2-143.8	INCH	14	0
Straightness	8	1.152 MAX	OK	INCH	8	0
Go-Gage	14	UNC-2A	OK		14	0
No-Go Gage	14	UNC-2A	OK		14	0

CHEMICAL ANALYSIS: HEAT NO : 6613040032

CHEMICAL ELEMENT (%)	C	Mn	P	S	Si	Cr	Mo	Ni	Al	Ti	V
SPECIFICATION ASTM A 193 GRADE B7	0.37-0.49	0.65-1.10	0.035 MAX	0.04 MAX	0.15-0.35	0.75-1.20	0.15-0.25				
TEST RESULT	0.39	0.76	0.010	0.005	0.17	0.9	0.18	0.09			
MACROETCH EXAMINATION			SUB-SURFACE CONDITIONS			RANDOM CONDITIONS		CENTER SEGREGATION			
SPECIFICATION ASTM A 193 GRADE B7			S 1 / S 2			R 1 / R 2		C 1 / C 2 / C 3			
TEST RESULT			S 1			R 1		C 1			

MECHANICAL PROPERTIES: ACCORDING TO ASTM A 193/A 193M-2010a GR.B7

TEST DATE: 2013-09-25 SAMPLED BY:WEIHAIJUN TITLE:QC MANAGER SAMPLING DATE: 2013-09-25

TEST ITEM	SAMPLE SIZE	SPECIFICATION	ACTUAL RESULT	ACCEPT	REJECT
TENSILE STRENGTH(KSD)	1	125 MIN	140	1	0
YIELD STRENGTH(KSD)	1	105 MIN	126	1	0
ELONGATION (%)	1	16.00 MIN	17.5	1	0
REDUCTION OF AREA (%)	1	50.00 MIN	56	1	0
TEMPERING TEMPERATURE(°C)		593 MIN	700		
HARDNESS(HRC)	1	35 MAX	30	1	0

DECARBURIZATION:OPTICAL METHOD ACCORDING TO ASTM A 193/A 193M-2010a GR.B7

TEST DATE: 2013-09-25 SAMPLED BY:WEIHAIJUN TITLE:QC MANAGER SAMPLING DATE: 2013-09-25

TEST ITEM	SAMPLE SIZE	SPECIFICATION	ACTUAL RESULT	UNIT	ACCEPT	REJECT
0.75hs From Root to Crest	1	0.046 MIN	0.055	INCH	1	0
0.1hs at Root	1	0.006 MAX	0.003	INCH	1	0

HEAT TREATMENT : INDUCTION-TYPE WITH POLYMER QUENCHING & TEMPERING
EN10204:2004.3.1 Certified SIGNATURE: WEIHAIJUN TITLE: QC MANAGER

Figure A-6. 3/4-in. (19-mm) Diameter Threaded Rod, Test Nos. SFH-1 and SFH-2

CERTIFICATE OF INSPECTION

Purchaser: PPC Date: 2014-6-10
 P.O.NO: PO 13082751 ISO NO: 15/14QS234R20
 INV NO: 214ZL070L-PPC Expire: 2017-03-21
 Manufacturer: ZHEJIANG GUORUI CO.,LTD.
 Address: No.283 Chengzi North Road,Wuyuan Town,Haiyan Zhejiang,P.R.China
 Commodity: ASTM A193 GR.B7 STUD, END TO END, W/B7*2MPG'S ID CUSTOMER PART NO.: 04175-3209-040
ON ENDS, CHAMFERED ON BOTH ENDS
 Size: 3/4-10 X 10-1/4 MANUFACTURING DATE: 2014.5.10
 Lot NO.: 213B249-13
 Ship quantity: 1960 MPCS MATERIAL: AISI 4140
 Finish: PLN

DIMENSIONAL INSPECTION ACCORDING TO ASME B18.31.2-2008
 TEST DATE: 2014-04-12 SAMPLED BY: LIUTAO TITLE: QC MANAGER SAMPLING DATE: 2014-04-12

INSPECTION ITEM	SAMPLE SIZE	SPECIFICATION	ACTUAL RESULT	UNIT	ACCEPT	REJECT
APPEARANCE	46	ASME B18.31.2-2008	OK		46	0
Marking	46	B7 AND CF	OK		46	0
Major Diameter	14	0.7482-0.7353	0.738-0.741	INCH	14	0
Length	14	10.37-10.13	10.18-10.27	INCH	14	0
Straightness	8	0.082 MAX	OK	INCH	8	0
Go-Go Gage	14	UNC-2A	OK		14	0
No-Go Gage	14	UNC-2A	OK		14	0

CHEMICAL ANALYSIS: HEAT NO: E11400347

CHEMICAL ELEMENT (%)	C	Mn	P	S	Si	Cr	Mo	Ni	Al	Ti	V
SPECIFICATION ASTM A 193 GRADE B7	0.37-0.49	0.65-1.10	0.035 MAX	0.04 MAX	0.15-0.35	0.75-1.20	0.15-0.25				
TEST RESULT	0.41	0.78	0.017	0.005	0.21	0.94	0.169				
MACROETCH EXAMINATION			SUB-SURFACE CONDITIONS			RANDOM CONDITIONS		CENTER SEGREGATION			
SPECIFICATION ASTM A 193 GRADE B7			S 1/S 2			R 1/R 2		C 1/C 2/C 3			
TEST RESULT			S 1			R 1		C 1			

MECHANICAL PROPERTIES: ACCORDING TO ASTM A 193/A 193M-2010a GR.B7
 TEST DATE: 2014-04-12 SAMPLED BY: LIUTAO TITLE: QC MANAGER SAMPLING DATE: 2014-04-12

TEST ITEM	SAMPLE SIZE	SPECIFICATION	ACTUAL RESULT	ACCEPT	REJECT
TENSILE STRENGTH(KSI)	1	125 MIN	137	1	0
YIELD STRENGTH(KSI)	1	105 MIN	119	1	0
ELONGATION (%)	1	16.00 MIN	19.5	1	0
REDUCTION OF AREA (%)	1	50.00 MIN	58	1	0
TEMPERING TEMPERATURE(°C)		593 MIN	630		
HARDNESS(HRC)	1	35 MAX	29	1	0

DECARBURIZATION OPTICAL METHOD ACCORDING TO ASTM A 193/A 193M-2010a GR.B7
 TEST DATE: 2014-04-12 SAMPLED BY: LIUTAO TITLE: QC MANAGER SAMPLING DATE: 2014-04-12

TEST ITEM	SAMPLE SIZE	SPECIFICATION	ACTUAL RESULT	UNIT	ACCEPT	REJECT
0.75hs From Root to Crest	1	0.046 MIN	0.052	INCH	1	0
0.1hs at Root	1	0.006 MAX	0.003	INCH	1	0

HEAT TREATMENT: CONTINUOUS-TYPE WITH OIL QUENCHING & TEMPERING
 EN10204:2004 3.1 Certified SIGNATURE: LIUTAO TITLE: QC MANAGER

Figure A-7. 3/4-in. (19-mm) Diameter Threaded Rod, Test No. SFH-3

KD FASTENERS, INC.

1440 Jeffrey Drive
Addison IL 60101

Tel: (630)543-1160
Fax: (630)543-4180

CERTIFICATE OF CONFORMANCE

TO: MIDWEST ROADSIDE SAFETY FACILITY
4800 NW 35TH ST
LINCOLN, NE 68524

SHIP DATE: 9/5/2014

This is to certify that all parts and/or materials included in this shipment have been manufactured and/or process in conformance with all applicable drawings, instructions and specifications.

SAFER FOR HIGHWAY-3
September 2014 SMT

PO NUMBER: SAFER

PART NUMBER	QTY SHIPPED
3/4-10 X 21" HEX C/S GRADE 5 PLAIN W/2-1/2" THREAD MIN	209 PIECES



KEVIN GRESCHUK, PRESIDENT

Figure A-8. 3/4-in. (19-mm) Diameter Hex Bolt, Test No. SFH-3

**KENNEDY
GALVANIZING
INC.**

Post Office Box 367 • Morris, Alabama 35116
Office (205) 647-6439 • Plant (205) 647-3806 • Fax (205) 647-4948

GALVANIZING CERTIFICATION:

We hereby certify that the following materials have been galvanized in accordance with the specifications as set forth by ASTM A 123/A 123 M-09 and ASTM-153/A 153 M-09. We further certify that fasteners we galvanize comply with the coating, workmanship, finish and appearance requirements of ASTM F2329-05.

Final inspection has been made and materials meet all requirements.

Customer Name: Atlanta Rod & Manufacturing
P.O. Box 435
Lavonia, GA 30553

Customer Order No.: NONE

Load Date: 2/19/2014
Load Number: NONE
Our Invoice No: 54744

Material Galvanized: TIMBER BOLT, U-BOLT, HHB, PW, DER, ATR & EYE BOLT

James Kennedy
James Kennedy, Plant Manager
Kennedy Galvanizing, Inc.

Figure A-9. 3/4-in. (19-mm) Diameter Hex Nut, Test Nos. SFH-1 through SFH-3

Raw Material Cert for Lot 320062A

NUCOR
NUCOR CORPORATION
NUCOR STEEL SOUTH CAROLINA

Mill Certification
8/14/2012

300 Steel Mill Road
DARLINGTON, SC 29540
(843) 393-5841
Fax: (843) 395-8701

Sold To: NUCOR FASTENER INDIANA
PO BOX 6100
ST JOE, IN 46785-0000
(800) 955-6826
Fax: (219) 337-1726

Ship To: NUCOR FASTENER
6730 COUNTY ROAD 60
ST JOE, IN 46785
(800) 955-6826
Fax: (219) 337-1722

RM 27738

Customer P.O.	131898	Sales Order	161814.1
Product Group	Special Bar Quality	Part Number	30001000396V780
Grade	1045L	Lot #	DL1210457701
Size	1" (1.0000) Round	Heat #	DL12104577
Product	1" (1.0000) Round 33 1045L	B.L. Number	C1-586023
Description	1045L	Load Number	C1-268799
Customer Spec		Customer Part #	025012

I hereby certify that the material described herein has been manufactured in accordance with the specifications and standards listed above and that it satisfies those requirements.

C	Mn	V	Si	S	P	Cu	Cr	Ni	Mo	Al	Cb
0.44%	0.61%	0.004%	0.17%	0.021%	0.008%	0.16%	0.10%	0.07%	0.01%	0.002%	0.002%
Pb	Sn	Ca	B	Ti	NICUMO						
0.002%	0.039%	0.0009%	0.0002%	0.001%	0.24						

NICUMO: Cu+Ni+Mo

Reduction Ratio 62 :1

ASTM E381
Surface: 2 Mid Radius: 2 Center: 2

Specification Comments: CHEMICAL ANALYSIS WAS PERFORMED BY NUCOR NE L.A.B. ACREDITIED CHEMICAL TESTING. CERT L-2232 EXPIRES 12-16-2012 ALL MATERIAL PRODUCED BY NUCOR SC IS EAF MELTED MATERIAL TESTED IN CONFORMANCE WITH ASTM A29-05, AND E415-08

1. WELDING OR WELD REPAIR WAS NOT PERFORMED ON THIS MATERIAL
2. MELTED AND MANUFACTURED IN THE USA
3. MERCURY, RADIUM, OR ALPHA SOURCE MATERIALS IN ANY FORM HAVE NOT BEEN USED IN THE PRODUCTION OF THIS MATERIAL

Chemistry Verification Checks

Part# 25012 RM# 27738

Checked By Date
Receiving OK: JGT 8-23-12
Certifications OK: 375 8-22-12

James H. Blew

James H. Blew
Division Metallurgist

Figure A-10. 1-in. (25-mm) Hex Head Bolt, Test Nos. SFH-1 through SFH-3



23513 Groesbeck Highway
Warren, Michigan 48089
(586)773-2700 * Fax (586)773-2298
www.PrestigeStamping.com

PRODUCT CERTIFICATION
CERTIFICATION NUMBER

118363

THIS IS TO CERTIFY THE PRODUCT STATED BELOW WAS FABRICATED AND PROCESSED TO THE ORDER AS INDICATED AND CONFORMS TO THE APPLICABLE SPECIFICATIONS AND STANDARDS.

Customer: THE STRUCTURAL BOLT CO 2140 CORNHUSKER HWY LINCOLN, NE 68521	
Customer Part: 3/4" F436 H/DIP Prestige Part: P1480HP300 Part Name: 3/4"F436 H/DIP Purchase Order: 15314-1 Shipment BOL: B172372 Shipment ID: A0183208 Quantity: 4200 Manufacturers Marking: "P"	Steel Supplier: HORIZON STEEL CO. Grade: CF436 GRADE STEEL Lot: C7602D Heat: 326352 Carbon: .251 (.21 - .93) Manganese: 1.31 (.43 - 1.6) Phosphorous: .01 (.03 Max.) Sulfur: .001 (.05 Max.) Silicon: .204
<u>SPECIFICATIONS</u> HARDNESS: TEST METHOD: ASTM E18 HRC 38 - 45 CHECK TO ASTM F606 PLATING: TEST METHOD: ASTM B499 0.0017" Min. HOT DIP GALV TO ASTM F-2329	<u>TEST RESULTS</u> HARDNESS: HRC 41 - 42 PLATING: 0.0020" - 0.0025"
<p>Chemistry is as reported from raw material certification and does not fall under Prestige Stamping's accreditation. This product was produced under an ISO/TS 16949 Quality Assurance System. ISO/TS 16949 Certification No: 0082933. Material was melted and manufactured in the U.S.A. This product was manufactured in Warren, Michigan U.S.A. This product conforms to all requirements for washers as produced according to A.S.T.M. F-436-10. Sampling Plan per P.S.I W.I. # 5.4.18.015. The test results only apply to the items tested. This test report must not be reproduced except in full without prior written approval. Materials used to manufacture these products are mercury, asbestos and radio activity free. No weld repairs made to material.</p>	

FRANK SCHUBERT
Quality Assurance Manager

Figure A-11. 3/4-in. (19-mm) Diameter Flat Washer, Test Nos. SFH-1 through SFH-3

NUCOR
FASTENER DIVISION

LOT NO.
3252548

Post Office Box 6100
Saint Joe, Indiana 46785
Telephone 260/337-1800

TEST REPORT SERIAL# FB410424
TEST REPORT ISSUE DATE 7/24/13
MANUFACTURE DATE 5/14/13
NAME OF LAB SAMPLER: JEFFREY HOERING, LAB TECHNICIAN

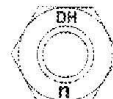

*****CERTIFIED MATERIAL TEST REPORT*****
PART NO. LOT NO. DESCRIPTION
175597 3252548 1/2-13 GR DH HV HX NUT H.D.G.
HEX NUT H.D.G.

--CHEMISTRY MATERIAL GRADE -1026L
MATERIAL HEAT **CHEMISTRY COMPOSITION (WT% HEAT ANALYSIS) BY MATERIAL SUPPLIER
NUMBER NUMBER C MN P S SI NUCOR STEEL - NEBRASKA
RM028016 NF12104365 .23 .75 .011 .021 .25
MIN .20 .60
MAX .55 .040 .050

--MECHANICAL PROPERTIES IN ACCORDANCE WITH ASTM A563-07a
SURFACE CORE PROOF LOAD TENSILE STRENGTH
HARDNESS HARDNESS 21300 LBS DEG-WEDGE STRESS (PSI)
(R30N) (RC) (LBS)
N/A 28.4 PASS N/A N/A
N/A 28.5 PASS N/A N/A
N/A 31.0 PASS N/A N/A
N/A 31.6 PASS N/A N/A
N/A 28.0 PASS N/A N/A
AVERAGE VALUES FROM TESTS PRODUCTION LOT SIZE 98500 PCS
29.5

ROTATIONAL CAPACITY TESTED IN ACCORDANCE WITH A325-10, A563-07a
SAMPLE #1 PASSED SAMPLE #2 PASSED

--VISUAL INSPECTION IN ACCORDANCE WITH ASTM A563-07a 80 PCS. SAMPLED LOT PASSED

--COATING - HOT DIP GALVANIZED TO ASTM F2329-11 - GALVANIZING PERFORMED IN THE U.S.A.
1. 0.00283 2. 0.00916 3. 0.00335 4. 0.00213 5. 0.00217 6. 0.00295 7. 0.00455
8. 0.00635 9. 0.00243 10. 0.00343 11. 0.00584 12. 0.00337 13. 0.00251 14. 0.00235
15. 0.00249
AVERAGE THICKNESS FROM 15 TESTS .00359
HEAT TREATMENT - AUSTENITIZED, OIL QUENCHED & TEMPERED (MIN 800 DEG F)

--DIMENSIONS PER ASME B18.2.6-2010
CHARACTERISTIC #SAMPLES TESTED MINIMUM MAXIMUM
Width Across Corners 8 0.9790 0.9900
Thickness 32 0.4750 0.4810

ALL TESTS ARE IN ACCORDANCE WITH THE LATEST REVISIONS OF THE METHODS PRESCRIBED IN THE APPLICABLE SAE AND ASTM SPECIFICATIONS. THE SAMPLES TESTED CONFORM TO THE SPECIFICATIONS AS DESCRIBED/LISTED ABOVE AND WERE MANUFACTURED FREE OF MERCURY CONTAMINATION. NO INTENTIONAL ADDITIONS OF BISMUTH, SELENIUM, TELLURIUM, OR LEAD WERE USED IN THE STEEL USED TO PRODUCE THIS PRODUCT. THE STEEL WAS MELTED AND MANUFACTURED IN THE U.S.A. AND THE PRODUCT WAS MANUFACTURED AND TESTED IN THE U.S.A. PRODUCT COMPLIES WITH DFARS 252.225-7014. WE CERTIFY THAT THIS DATA IS A TRUE REPRESENTATION OF INFORMATION PROVIDED BY THE MATERIAL SUPPLIER AND OUR TESTING LABORATORY. THIS CERTIFIED MATERIAL TEST REPORT RELATES ONLY TO THE ITEMS LISTED ON THIS DOCUMENT AND MAY NOT BE REPRODUCED EXCEPT IN FULL.



MECHANICAL FASTENER
CERTIFICATE NO. A2LA 0139.01
EXPIRATION DATE 12/31/13

NUCOR FASTENER
A DIVISION OF NUCOR CORPORATION

John W. Ferguson
JOHN W. FERGUSON
QUALITY ASSURANCE SUPERVISOR

Figure A-12. 1/2-in. (13-mm) Diameter Nut, Test Nos. SFH-1 through SFH-3

Raw Material Cert for Lot 325254B

Nucor Steel 2/9/2013 9:27:41 AM PAGE 2/002 Fax Server

NUCOR
NUCOR CORPORATION
NUCOR STEEL NEBRASKA

Mill Certification
2/9/2013

278016
2911 East Nucor Road
NORFOLK, NE 68701
(402) 644-0200
Fax: (402) 644-0328

Sold To: NUCOR FASTENER INDIANA
PO BOX 6100
6730 COUNTY RD 60
ST JOE, IN 46785-0000
(260) 337-1600
Fax: (435) 734-4581

Ship To: NUCOR FASTENER INDIANA
COUNTY RD 60
ST JOE, IN 46785-0000

Customer P.O.	135757	Sales Order	126701.14
Product Group	Special Bar Quality	Part Number	31B00875000W680
Grade	1026L	Lot #	NF1210436511
Size	.8750-7/8 Round Coil	Heat #	NF12104365
Product	.8750-7/8 Round Coil 1026L	B.L. Number	N1-246876
Description	1026L	Load Number	N1-193067
Customer Spec		Customer Part #	CH5008

I hereby certify that the material described herein has been manufactured in accordance with the specifications and standards listed above and that it satisfies those requirements.

Roll Date: 2/8/2013 Melt Date: 12/5/2012 Qty Shipped LBS: 160,995 Qty Shipped Pcs: 32

C	Mn	V	Si	S	P	Cu	Cr	Ni	Mo	Al	Cb
0.23%	0.75%	0.003%	0.25%	0.021%	0.011%	0.06%	0.08%	0.04%	0.01%	0.001%	0.002%
Pb	Sn	Ca	B	Ti							
0.000%	0.005%	0.0007%	0.0002%	0.001%							

Reduction Ratio 73 :1

Specification Comments: Coarse Grain Practice

Selenium, Tellurium, Lead, Bismuth or Boron were not intentionally added to this heat.

- All manufacturing processes of the steel materials in this product, including melting, have been performed in the United States.
- All products produced are weld free.
- Mercury, in any form, has not been used in the production or testing of this material.
- Test conform to ASTM A29-12, ASTM E415 and ASTM E1019-resulphurized grades or applicable customer requirements.
- All material melted at Nucor Steel Nebraska is produced in an Electric Arc Furnace
- Strand Cast
- ISO-17025 LAB accreditation cert. available upon request

Chemistry Verification Checks

Part# CH5008 RM# 278016

Checked By Date
Receiving OK: 297 2-18-13
Certifications OK: 375 2-18-13

[Signature]

Jim Hill
Division Metallurgist

Figure A-13. 1/2-in. (13-mm) Diameter Nut, Test Nos. SFH-1 through SFH-3

GAFFNEY BOLT COMPANY
6100 MATERIAL AVENUE
ROCKFORD, IL 61111

FASTENER TEST REPORT

DATE SHIPPED:	FEB. 24, 2014	LOT NO:	36046
CUSTOMER:	THE STRUCTURAL BOLT COMPANY		
P.O. NO:	15243	QUANTITY:	88
DESCRIPTION:	1-8 X 11 1/2 A325 HVYHEX HDG	HEAT NO:	133782

HEAT CHEMICAL ANALYSIS ATTACHED

MATERIAL:	1045	ROCKWELL:	31-32 30.7
TENSILE:	96,940 LBS	PROOFLOAD:	51,500 LBS

PASSED VISUAL INSPECTION

ALL TEST ARE IN ACCORDANCE WITH THE METHODS PRESCRIBED IN THE APPLICABLE SAE AND ASTM SPECIFICATIONS. PRODUCT MEETS ASME B18.2.6 DIMENSIONAL SPECIFICATION AND THREADS MEET ANSI B1.1 CLASS 2A. WE CERTIFY THAT THIS DATA IS TRUE REPRESENTATION OF INFORMATION PROVIDED BY THE MATERIAL SUPPLIER AND OUR TESTING LABORATORY.

THESE PARTS WERE MANUFACTURED BY GAFFNEY BOLT COMPANY FROM STEEL MELTED AND MANUFACTURED IN THE USA.

GAFFNEY BOLT COMPANY
Mary P. Gaffney
MARY P. GAFFNEY
SECRETARY

Figure A-14. 1-in. (25-mm) Diameter Hex Head Bolt, Test Nos. SFH-1 through SFH-3

From: Perlow Steel Corporation
Heat#: 133782

Date: 2/26/2014 Ln#: 0 Part: C1.0001045ALT

Qty: 0



CERTIFIED MILL TEST REPORT

Alton Steel Test Lab
#5 Cut Street
Alton, IL 62002-9011
(618) 463-4490 EXT 2486
(618) 463-4491 (Fax)

BILL TO	SHIP TO
Perlow Steel 2900 South 25th Avenue Broadview, IL 60155	Perlow Steel 2900 South 25th Avenue Broadview, IL 60155

Date: 01/08/2014	Customer PO: P4466	Specifications: SAE 1045, ASTM A 29-12, ASTM A 576-90b (12)
ASI Ord No: 64317	Customer PT: C1.0001045ALT	
ASI Ord Line Item: 1		

Item Description: Steel Bar, Hot Rolled, 1.0000, 20' 0" Strand Cast, RR =62.39:1

Heat Number Yield PSI Tensile PSI % Elongation % ROA Bend Test

CHEMICAL ANALYSIS TEST METHODS ASTM E-415 & E-1019

Heat Number	C	Mn	P	S	Si	Cu	Ni	Cr	Mo	Sn	Al	Nb/Cb	V	B	Ti	N	Ca
133782	0.45	0.79	0.012	0.022	0.20	0.26	0.082	0.159	0.027	0.011	0.004	0.024	0.005	0.0003	0.0008	0.0134	0.0060

JOMINY HARDENABILITY USING ASTM A-255 CALCULATED FROM CHEMICAL DI

Heat Number	GS	DI
133782	7	1.55

SPECIAL TEST RESULTS

Heat Number	ASTM E-45 Method A:				ASTM E-45 Method C:				SAE J422		ASTM E-381		PW 12286		Ferritic GS		Hardness			
	TA	TB	TC	TD	HA	HB	HC	HD	S	O	S	O	S	R	C	A	B	RC	RB	BHN
133782											3	2								193

ADDITIONAL COMMENTS

No mercury, lead, radium, or alpha containing material or equipment is used or deliberately added in the production of this steel. No weld or weld repairs were performed on this material. This Steel is 100% Electric Arc Furnace Melted and Rolled in the U.S.A. Material qualifies as NAFTA origination.

Alteration or reproduction of this report, except in full, is not allowed without written approval by a representative of Alton Steel Incorporated.

I hereby certify that the above tests are correct as contained in the records of ALTON STEEL INCORPORATED

Subscribed and sworn to before me, a Notary Public, in and for the county of Madison, State of Illinois

Quality Leader: Josh Levi

this _____ Day of _____

My commission expires _____

(Notary Public)



Figure A-15. 1-in. (25-mm) Diameter Hex Head Bolt, Test Nos. SFH-1 through SFH-3



W.W. Grainger, Inc.
100 Grainger Parkway
Lake Forest, IL. 60045-5201

August 03 2012

Attn: KEN KRENK
UNIVERSITY HEALTH CENTER
1500 U STREET
LINCOLN, NE, 68503-0000

Fax #

Grainger Sales Order #: 1157994181
Customer PO #: 045562765

Dear KEN KRENK
As you requested, we are providing you with the following information. We certify that, to the best of Grainger's actual knowledge, the products described below conform to the respective manufacturer's specifications as described and approved by the manufacturer.

Item #	Description	Vendor Part #	Catalog Page #
4FGZ8	Threaded Rod,Gr 2,3/4-10 x 6 Ft,RH,UNC	4FGZ8	3060
2FE85	Hex Nut,Grade 2,3/4-10,PK20	HNG20750010020Z	2929
6PU26	Flat Washer,Ylw Zinc,Fits 3/4 In,Pk 20	HS-0750SAEHZYBAGGR	2957

If you need any additional information, please contact our Compliance Team at 847-647-4649 or prod_mgmt_support@grainger.com.

Gary Figiel
Engineering Technician
Compliance Team
Grainger Industrial Supply

Figure A-16. 3/4-in. (19-mm) Hex Nut, Test Nos. SFH-1 through SFH-3

GENERAL TESTING LABORATORIES

TELEPHONE (402)434-1891
FAX (402)434-2161

P. O. BOX 29529
LINCOLN, NEBRASKA 68529

CONCRETE INDUSTRIES
STRUCTURAL DIVISION

April 29, 2014

CONCRETE MIX DESIGN FOR: University of Nebraska - Lincoln
Lightweight Concrete
Barrier Curb

Mix # 92443003

MATERIAL	WT/CU YD	SUPPLIER
Portland Cement Type III, Grey	658 lb	Central Plains Kansas City, MO
Lightweight Aggregate	984 lb *	Buildex, Inc. Ottawa, KS
C33 Sand (SSD)	1391 lb *	Western Sand & Gravel Ashland, NE
Total Water	27.0 gal	Lincoln Water System Lincoln, NE
Air Entraining Admixture, MB-AE-90	6 ± 1.5%	Master Builders, Inc Cleveland, OH
Viscosity Modifier Acti-Gel	1.5 lb/yd	Active Minerals
High Range Water Reducer Glenium 3030	5-10 oz/cwt (As needed for Slump Control)	Master Builders, Inc Cleveland, OH

* Exact quantity will vary
with changes in lightweight
SpG and Unit Weight.

General Testing Lab,



Rod Leber, Manager

Figure A-17. Concrete Beam, Test Nos. SFH-1 through SFH-3

GENERAL TESTING LABORATORIES

TELEPHONE (402)434-1891
 FAX (402)434-2161

P. O. BOX 29529
 LINCOLN, NEBRASKA 68529

CONCRETE INDUSTRIES
 STRUCTURAL DIVISION
 CONCRETE MIX DESIGN FOR:

April 29, 2014

University of Nebraska - Lincoln
 Lightweight Concrete
 Barrier Curb

Mix # 92443003

Strength Test Results

DATE	REL. DAYS	SURE AVG	7 DAY	28 AVG
4/1/2014	1	4560	5199	6652
4/3/2014	1	5505	6768	
4/4/2014	3	6755	6634	
4/7/2014	1	4430	5379	
4/8/2014	1	4510	7150	
4/9/2014	1	4140	5937	
4/10/2014	1	4280	6290	
4/11/2014	3	3895	5522	
4/14/2014	1	4855	6253	
4/15/2014	1	4175	5577	
4/16/2014	1	3665	5449	
4/17/2014	1	4090	5392	

Oven Dry and Equilibrium Densities

ASTM C567-9.1-05a

By Calculation	By Oven-Dry Density
104 lb/ft ³	108 lb/ft ³

General Testing Lab,



Rod Leber, Manager

Figure A-18. Concrete Beam, Test Nos. SFH-1 through SFH-3

GENERAL TESTING LABORATORIES

TELEPHONE (402)434-1891
FAX (402)434-1899

P. O. BOX 29529
LINCOLN, NEBRASKA 68529

AGGREGATE DATA

1/2" x 4 Expanded Shale Gradation

SCREEN:	3/4"	1/2"	3/8"	#4	#8	#16	#30	#50
ASTM C330 Spec:	0-10		50-90	85-100				
% Retained:	0	18	60	96	98	99	99	99

C33 SAND

SCREEN:	3/8"	#4	#8	#16	#30	#50	#100	#200
ASTM C33 Spec:	0	0/5	0/20	15/50	40/75	70/90	90/98*	100
% RETAINED:	0	1	15	39	69	92	99	

Bulk Specific Gravity (SSD): 2.62
24 Hour Absorption: 0.6%
LA Abrasion Loss: 27%
Sulfate Soundness Loss: 2.0%
Deleterious Materials: <0.5%
Soluble Chloride Ion Content: <0.001%
Organic Impurities: None
Fineness Modulus: 3.15
Sand Equivalent: >99%

Figure A-19. Concrete Beam, Test Nos. SFH-1 through SFH-3



**Central Plains
Cement Company**



Certified to NSF/ANSI 61

Cement Mill Test Report

Month of Issue: **Apr-14**

Plant: **Sugar Creek Plant**
Product: **Portland Cement Type III**
Shipped: **Mar-14**
Manufactured: **Mar-14**

The current version of ASTM C 150 and AASHTO M 85 Standard Requirements

CHEMICAL ANALYSIS			PHYSICAL ANALYSIS		
Item	Spec limit	Test Result	Item	Spec limit	Test Result
Rapid Method, X-Ray (C 114)			Air content of mortar (%) (C 185)	12 max	8
SiO ₂ (%)	---	20.2	Blaine Fineness (m ² /kg) (C 204)	---	582
Al ₂ O ₃ (%)	---	4.8	-325 (%) (C 430)	---	97.9
Fe ₂ O ₃ (%)	---	3.2	Autoclave expansion (%) (C 151)	0.80 max	-0.01
CaO (%)	---	63.6	Compressive strength (PSI) (C 109)		
MgO (%)	6.0 max	1.1	1 day	1740 min	3800
SO ₃ (%) *	3.5 max	4.4	3 days	3480 min	5130
Loss on ignition (%)	3.0 max	1.2	28 days (Reflects previous month's data)	---	8380
Insoluble residue (%)	0.75 max	0.70	Time of setting (minutes)		
Adjusted Potential Phase Composition (C 150)			Vicat Initial (C 191)	45 - 375	56
C3S (%)	---	56	Specific Gravity (C188)	---	3.15
C2S (%)	---	15	False Set (%) (C 451)	50 min	76
C3A (%)	15 max	7	Mortar Bar Expansion (%) (C 1038) *	0.020 max	0.006
C4AF (%)	---	10			
ASTM C 150-09 and AASHTO M 85-09 Optional Chemical Requirements:					
NaEq (%)	0.60 max	0.56			

* May exceed 3.5% SO₃ maximum based on our C 1038 results of <0.020% expansion at 14 days.

We certify that the above described cement meets the chemical and physical requirements of Type III for the current version of ASTM C 150 & AASHTO M 85 STANDARD.

Sugar Creek Plant
2200 N Courtney Rd.
Sugar Creek, MO 64050
816-257-3608

Certified By:

Adam Doppenberg - Quality Coordinator

4/10/2014

Figure A-20. Concrete Beam, Test Nos. SFH-1 through SFH-3

Dom 6.500 x .375

55720-9

TEST REPORT



Alliance Tubular Products LLC
A PTC Alliance Company
P.O. Box 2298
Alliance, OH 44601-0298

**BUY
AMERICAN**

SHIP TO NATIONAL TUBE SUPPLY CO. 925 CENTRAL AVE. UNIVERSITY PARK, IL 60484	PURCHASE ORDER NUMBER	PTC Order Number	PAGE	FORM:
	55720-009	505894	1	48-001
SHIP TO NATIONAL TUBE SUPPLY CO. 925 CENTRAL AVE. UNIVERSITY PARK, IL 60484	The following tests were successfully performed: NON-DESTRUCTIVE ELECTRICALLY TESTED			
	MELTED AND MFG. IN THE U.S.A. UNLESS NOTED OTHERWISE BY VENDOR NAME			
The following shipments are included in this report:				
SHIP DATE:	05/22/14			Killed Steel
B/L NUMBER:	05135814	ship# 0001		

Inches (mm)

ERW STEEL MECHANICAL TUBES- CD SIZE: 6.500 (165.10) OD x 5.750 (146.05) ID
SPEC: ASTM A513-12 1026, ERW, TYPE 5, SRA, AW, MECHANICAL TUBING
SPEC: Certification done in compliance with EN 10204:2004 Type 3.1
GRADE: 1026 / 228MC HT: STRESS RELIEVE

SFH SKID SUPPORT TUBING R#14-0519

HEAT NUMBER	PCS.	TOTAL LENGTH SHIPPED	YS- ksi (N/mm2)	TS- ksi (N/mm2)	% ELONG. IN 2"	HARDNESS	Y/T
NLK1474573	40	920'	88.2 (608)	97.6 (673)	15%	93 RB	
DLMK PENNSYLVANIA CORP Reduction Ratio: 21.8 MELTED IN RUSSIA THIS STATEMENT IS TO CONFIRM THAT ALL MATERIALS MANUFACTURED BY PTC ALLIANCE AND ITS SUBSIDIARIES ARE FREE OF MERCURY CONTAMINATION AND/OR MERCURY COMPOUNDS.* *AS DEFINED BY CADSL V1.0 2005-01-25, AND ROHS DIRECTIVE (2002/95/EC)							

HEAT NO.	TYPE	C	MN	P	S	SI	CR	NI	MO	CU	AL	CA	V	SN
NLK1474573	LADLE	0.23	0.66	.008	.005	0.04	0.01	0.01	<.01	0.02	.060	.002	.001	<.01

THIS IS TO CERTIFY THAT THE ABOVE PRODUCTS HAVE BEEN MADE IN THE U.S.A. AND HAVE BEEN INSPECTED AND TESTED IN ACCORDANCE WITH AND HAVE MET ALL REQUIREMENTS OF THE SPECIFICATION.
PTC ALLIANCE by

David E. Muntz

"THE RECORDING OF FALSE, FICTITIOUS OR FRAUDULENT STATEMENTS OR ENTRIES ON THIS DOCUMENT MAY BE PUNISHED AS A FELONY UNDER FEDERAL STATUTES, INCLUDING FEDERAL LAW, TITLE 18, CHAPTER 47."

Figure A-21. Skid Steel Tube, Test Nos. SFH-1 through SFH-3



BRANCH ADDRESS
LINCOLN BRANCH
4800 NORTH 57TH STREET
LINCOLN NE 68507

INVOICE

SHIP TO (SAME AS "SOLD TO" UNLESS SHOWN)
UNIVERSITY OF NEBRASKA
W342 NE HALL
LINCOLN, NE 68588

INVOICE DATE
06/17/14 ORIGINAL

INVOICE NUMBER
NE02-184020

PH (402) 467-1153 CREDIT CARD RECEIPT
FAX (402) 467-1157

SOLD TO
CARD NAME: VISA
CARD#: 5821
APP CODE: 092503 CNTRL #
MERCHANT: 001113812702

PO / RELEASE NUMBER
KEN
402-770-9121
REMIT TO:

ENT BY: NE020822 DIST: 0

TAKEN BY: SB US

PAGE 1 OF 1

ORDER DATE 06/12/14	TERMS CRDTCD	SHIP DATE 06/17/14	SHIP VIA CUST.PICK-UP	ACCT NUMBER BR 101501-01	F.O.B FOB ORG, FRT PP&ADD
ORDER DUE DATE 06/26/14	OCN OCN: 153425	COMMENTS			

LINE	VEN	MI NO.	DESCRIPTION	CUSTOMER INFORMATION	CUST PO ITEM	QUANTITIES			UNIT PRICE	UNIT	NET AMOUNT
						ORDER	B/O	SHIPPED			
1	03185	Z 44000	1/2"T 24"W 12"L EPDM 60 DURO RUBBER			1	0	1	458.790	EA	458.79

PLEASE BE SURE TO INCLUDE THE ENTIRE INVOICE NUMBER ON YOUR REMITTANCE ADVICE IN ORDER TO ENSURE YOUR FUNDS ARE PROPERLY APPLIED.

MDSE. TOTAL	FREIGHT	OTHER CHARGES	SALES TAX		CASH DISCOUNT	TOTAL DUE
458.79	32.43	RESTOCKING	PCT	AMOUNT		PAID IN FULL
	IN .00	.00	.0000	.00		491.2
	OUT	.00				

BUYER UNDERSTANDS AND AGREES THAT GOODS PRESENTED TO BUYER PURSUANT TO THIS INVOICE ARE BEING TENDERED CONTINGENT UPON BUYER'S AGREEMENT TO ALL TERMS AND CONDITIONS RELATED TO SALES. MOTION'S TERMS AND CONDITIONS ARE AVAILABLE AT THE MOTION BRANCH OR AT: WWW.MOTIONINDUSTRIES.COM. BUYER'S ACCEPTANCE OF THE DELIVERY OF THE GOODS SHALL CONFIRM BUYER'S AGREEMENT TO ALL OF MOTION'S TERMS AND CONDITIONS.

INVOICE

Figure A-22. Rubber Padding For Skid, Test Nos. SFH-1 through SFH-3



ArcelorMittal LaPlace
138 HWY 3217
LaPlace LOUISIANA 70068
Telephone (985) 652-4900

MATERIAL CERTIFICATION REPORT

STEEL & PIPE SUPPLY
555 Poyntz Avenue
66505-1688 Manhattan

STEEL & PIPE SUPPLY
GARDNER, KS
401 NEW CENTRY PKWY
66031 Gardner

Tested in Accordance
With: ASTM A6

Invoice NO.
Product Equal Angl
Heat NO. **L92705**
Length 40' 00"

Date 12/27/2013
Cust 40006650
Grade A3652950
Size 6"x6"x1/2"x19.600

PO: 4500211964
Ref. 80603760
Pieces 36

CHEMICAL ANALYSIS		MECHANICAL PROPERTIES	TEST 1		TEST 2		TEST 3	
			IMPERIAL	METRIC	IMPERIAL	METRIC	IMPERIAL	METRIC
C	0.12	YIELD STRENGTH	52000 PSI	359 MPa	54000 PSI	372 MPa		
Mn	0.90	TENSILE STRENGTH	72300 PSI	498 MPa	71600 PSI	494 MPa		
P	0.012	ELONGATION	26 %	26 %	20 %	20 %		
S	0.036	GAUGE LENGTH	8 IN	203 mm	8 IN	203 mm		
Si	0.20	BEND TEST DIAMETER						
Cu	0.21	BEND TEST RESULTS						
Ni	0.11	SPECIMEN AREA						
Cr	0.15	REDUCTION OF AREA						
Mo	0.034	IMPACT STRENGTH						
Cb	0.016							
V	0							
B								
Al		IMPACT STRENGTH	IMPERIAL	METRIC	INTERNAL CLEANLINESS	GRAIN SIZE		
Sn	0.012	AVERAGE			SEVERITY	HARDNESS		
N		TEST TEMP			FREQUENCY	GRAIN PRACTICE		
Ti		ORIENTATION			RATING	REDUCTION RATIO		

A36-08, A52950-05, C40.21-CSA50W, 44W, A70936-09a, AASHTO M270 Grade 36, AASHTO M270 Grade 50, AASHTO M270M Grade 345, ASME SA36-2010, A57250-07, A70950-10.

I hereby certify that the material test results presented here are from the reported heat and are correct. All tests were performed in accordance to the specification reported above. All steel is electric furnace melted (billets), manufactured, processed, and tested in the U.S.A with satisfactory results, and is free of Mercury contamination in the process. No weld repair was performed on this heat.

Notarized upon request:
Sworn to and subscribed before me in and for ST. John Parish on this 27th day of December, 2013

Notary Public

Signed Mark Edwards
MARK EDWARDS, QUALITY ASSURANCE SUPERVISOR

Direct any questions or necessary clarifications concerning this report to the Sales Department 1-800-535-7692(USA)

SAFER FOR HIGHWAY

R# 14-0340 PO# 4500267570

FEB 2014 SMT

205

Figure A-23. L-Bracket for ACJ, Test Nos. SFH-1 through SFH-3

METALLURGICAL TEST REPORT

SPS Coil Processing Tulsa
5275 Bird Creek Ave.
Port of Catoosa, OK 74015

PAGE 1 of 1
DATE 07/18/2013
TIME 16:44:18
USER MEHEULAL

S 21489
O Owens Specialty Company, Inc.
L Inc.
D 187
T Channelview TX 77530
O

S 21489
H Owens Specialty Company,
I Inc.
P 16014 Bear Bayou Drive
T Channelview TX 77530
O

Order	Material No.	Description	Quantity	Weight	Customer Part	Customer PO	Ship Date
1562123-0020	72696128A2	3/16 96 X 128 A572GR50 MILL PLATE				13-9602-607	07/18/2013

Chemical Analysis

Heat No.	Vendor	SSAB - MONTPELIER WORKS	DOMESTIC	Mill	SSAB - MONTPELIER WORKS	Melted and Manufactured in the USA															
Batch	2 EA	1,307.300 LB				Carbon	Manganese	Phosphorus	Sulphur	Silicon	Nickel	Chromium	Molybdenum	Boron	Copper	Aluminum	Titanium	Vanadium	Columbium	Nitrogen	Tin
A3F101						0.0500	1.1300	0.0130	0.0090	0.0200	0.1600	0.0900	0.0400	0.0000	0.2600	0.0230	0.0020	0.0500	0.0020	0.0000	0.0000

Mechanical/ Physical Properties

Mill Coil No.	Tensile	Yield	Elong	Rckwl	Grain	Charpy	Charpy Dr	Charpy Sz	Temperature	Olsen
0272	79300.000	69300.000	26.10	0	0.000	42	NA	3.3		
	76000.000	66700.000	30.50	0	0.000	39	NA	3.3		
						44	NA	3.3		

THE CHEMICAL, PHYSICAL, OR MECHANICAL TESTS REPORTED ABOVE ACCURATELY REFLECT INFORMATION AS CONTAINED IN THE RECORDS OF THE CORPORATION.

206

Figure A-24. Bent Plate, Test Nos. SFH-1 through SFH-3

SSAB

Test Certificate

Form TCI: Revision 1: Date 31 Oct 2000

1770 Bill Sharp Boulevard, Muscatine, IA 52761-9412

Customer: STEEL & PIPE SUPPLY P.O. BOX 1688 MANHATTAN KS 66502		Customer P.O. No.: 4500202317	Mill Order No.: 41-362422-02	Shipping Manifest : MT198825															
Product Description: ASTM A572-50/M345(07)/A709-50/M345(11)			Ship Date: 27 May 13	Cert No: 061388727															
Size: 0.500 X 96.00 X 240.0 (IN)			Cert Date: 27 May 13	(Page 1 of 1)															
Tested Pieces			Tensiles				Charpy Impact Tests												
Heat Id	Piece Id	Tested Thickness	Tst Loc	YS (KSI)	UTS (KSI)	%RA	Elong % 2in 8in	Tst Dir	Average Hardness	Abs. Energy(FTLB)			% Shear			Tst Tmp	Tst Dir	Tst Siz (mm)	BDWTT Twp %Str
A3D099	A27	0.495 (DISCRT)	L	66	86		30	T		1	2	3	Avg	1	2	3	Avg		
Chemical Analysis																			
Heat Id	C	Mn	P	S	Si	Tot Al	Cu	Ni	Cr	Mo	Cb	V	Ti	ORGN					
A3D099	.18	1.24	.011	.002	.19	.028	.32	.18	.08	.04	.001	.049	.007	USA					
MERCURY IS NOT A METALLURGICAL COMPONENT OF THE STEEL AND NO MERCURY WAS INTENTIONALLY ADDED DURING THE MANUFACTURE OF THIS PRODUCT MTR EN 10204:2004 INSPECTION CERTIFICATE 3.1 COMPLIANT 100% MELTED AND MANUFACTURED IN THE USA. PRODUCTS SHIPPED: A3D099 A27 PCS: 6, WGT: 19664																			
(9) Cust Part # :										WE HEREBY CERTIFY THAT THIS MATERIAL WAS TESTED IN ACCORDANCE WITH, AND MEETS THE REQUIREMENTS OF, THE APPROPRIATE SPECIFICATION							B. H. Wales SENIOR METALLURGIST-PRODUCT		

207

Figure A-25. Top Plate on Skid, Test Nos. SFH-1 through SFH-3

SPS Coil Processing Tulsa
 5275 Bird Creek Ave.
 Port of Catoosa, OK 74015



METALLURGICAL TEST REPORT

PAGE 1 of 1
 DATE 12/20/2013
 TIME 10:17:54
 USER GIANGRER

S
O
L
I
D

S
H
I
P
T
O

13716
 Warehouse 0040
 401 New Century Parkway
 New Century KS 66031

Order	Material No.	Description	Quantity	Weight	Customer Part	Customer PO	Ship Date
40214770-0020	72898120A2	1/4 96 X 120 A572GR50 MILL PLATE	1	816.800			12/20/2013

Chemical Analysis

Heat No.	Vendor	DOMESTIC											Melted and Manufactured in the USA				
Batch	EA	Mill SSAB - MONTPELIER WORKS											Produced from Coil				
Carbon	Manganese	Phosphorus	Sulphur	Silicon	Nickel	Chromium	Molybdenum	Boron	Copper	Aluminum	Titanium	Vanadium	Columbium	Nitrogen	Tin		
A31030	SSAB - MONTPELIER WORKS	0.0500	1.1300	0.0140	0.0040	0.0300	0.1300	0.0900	0.0300	0.0000	0.2900	0.0320	0.0020	0.0490	0.0020	0.0000	0.0000

Mechanical/ Physical Properties

Mill Coil No.	Tensile	Yield	Elong	Rckwl	Grain	Charpy	Charpy Dr	Charpy Sz	Temperature	Olsen
0193	66640.000	55949.000	30.10	0	0.000	0	NA			
	77043.000	66222.000	31.30	0	0.000	0	NA			

THE CHEMICAL, PHYSICAL, OR MECHANICAL TESTS REPORTED ABOVE ACCURATELY REFLECT INFORMATION AS CONTAINED IN THE RECORDS OF THE CORPORATION.

208

Figure A-26. Base Plate on Skid, Test Nos. SFH-1 through SFH-3

MILL TEST CERTIFICATE

1700 HOLT RD N.E.
 Tuscaloosa, AL 35404-1000
 800-827-8872

Load Number	Tally	Mill Order Number	PO NO Line NO	Part Number	Certificate Number	Prepared																
T043833	00000000522765	N-124831-003	4500211285 3		L440577-1	10/05/2013 13:40																
Grade				Customer:																		
Order Description: A572/A709, 0.3750 IN x 96.000 IN x 240.000 IN				Sold TO: STEEL AND PIPE SUPPLY CO INC GARDNER KS																		
Quality Plan Description: A57250/A70950: ASTM A572-50-07/A709-50-11				Ship TO: Kansas City Warehouse New Century KS																		
Shipped Item	Heat/Slab Number	Certified By	C	Mn	P	S	Si	Cu	Ni	Cr	Mo	Cb	V	Al	Ti	N2	B	Ca	Sn	CEV		
3I2051E	A3V3389-01 ***	A3V3389	0.16	1.21	0.011	0.007	0.04	0.22	0.05	0.08	0.016	0.034	0.048	0.022	0.001	0.009	0.0000	0.0019	0.007	0.41		
3I2276E	A3V3417-02 ***	A3V3417	0.06	1.13	0.008	0.004	0.18	0.19	0.06	0.07	0.020	0.031	0.004	0.032	0.014	0.008	0.0000	0.0043	0.007	0.28		
Shipped Item	Certified By	Heat Number	Yield ksi	Tensile ksi	Y/T %	ELONGATION %		Bend OK?	Hard HB	Charpy Impacts (ft-lbs)				Shear %			Test Temp					
						2"	8"			Size mm	1	2	3	Avg	1	2		3	Avg			
3I2051E	S3I2050FTT	A3V3389 ***	70.0	89.0	78.7	25.3																
3I2051E	S3I2053FTT	A3V3389 ***	69.0	87.9	78.5	25.3																
3I2051E	S3I2050MTT	A3V3389 ***	72.9	91.1	80.0	21.0																
3I2051E	S3I2053MTT	A3V3389 ***	70.3	90.0	78.1	21.7																
3I2276E	S3I2276FTT	A3V3417 ***	55.8	66.7	83.7	34.6																
3I2276E	S3I2276MTT	A3V3417 ***	58.8	66.8	88.0	29.4																

Items: 2 PCS: 9 Weight: 22053 LBS

Mercury has not come in contact with this product during the manufacturing process nor has any mercury been used by the manufacturing process. Certified in accordance with EN 10204 3.1. No weld repair has been performed on this material. Manufactured to a fully killed fine grain practice. NUTEMPER TEMPER PASSED plate from coil ISO 9001:2008 Registered, PED Certified

We hereby certify that the product described above passed all of the tests required by the specifications.

Quilin Yu
 Dr. Quilin Yu - Metallurgist

**** indicates Heats melted and Manufactured in the U.S.A.

209

Figure A-27. Skid Gusset Plate, Test Nos. SFH-1 through SFH-3

MATERIAL TEST REPORT
 Date Printed: 23-DEC-13

Date Shipped: 23-DEC-13	Product: DEF #4 (1/2")	Specification: ASTM A-706/A-615
FWIP: 52815348	Customer: CONCRETE INDUSTRIES INC	Cust. PO: 104050

Heat Number	CHEMICAL ANALYSIS															
	C	Mn	P	S	Si	Cu	Ni	Cr	Mo	Al	V	B	Cb	Sn	N	Ti
566673	0.28	1.22	0.006	0.014	0.27	0.24	0.08	0.11	0.019	0.003	0.038	0.0005	0.000	0.011	0.0086	0.001
Carbon Equivalent = 0.500																

Heat Number	Sample No.	MECHANICAL PROPERTIES					Bend	Wt/ft
		Yield (Psi)	Ultimate (Psi)	Elongation (%)	Reduction (%)			
566673	01	0.2% offset	69317	95280	16.0	ok	0.677	
		(MPa)	477.9	656.9				
566673	02	0.0035 EUL	62581	97040	16.1	ok	0.677	
		(MPa)	431.5	669.1				

All melting and manufacturing processes of the material subject to this test certificate occurred in the United States of America.
 ERMS also certifies this material to be free from Mercury contamination.
 This material has been produced and tested in accordance with the requirements of the applicable specifications. We hereby certify that the above test results represent those contained in the records of the Company.

Mark Espaner

Quality Assurance Department

FROM SHIPPING WEST (NON) DEC 23 2013 15:50/ST. 15:50/NO. 75272995Z P. 9

210

Figure A-28. Long-Bent Rebar, Test Nos. SFH-1 through SFH-3



US-ML-ST PAUL
1678 RED ROCK ROAD
SAINT PAUL, MN 55119
USA

CERTIFIED MATERIAL TEST REPORT

CUSTOMER SHIP TO NEBCO INC STEEL DIVISION HAVELOCK, NE 68529 USA		CUSTOMER BILL TO CONCRETE INDUSTRIES INC LINCOLN, NE 68529-0529 USA		GRADE 60 (420)	SHAPE / SIZE Rebar / #6 (19MM)	
SALES ORDER 707645/000010		CUSTOMER MATERIAL N°		LENGTH 60'00"	WEIGHT 56,687 LB	HEAT / BATCH 62133268/02
CUSTOMER PURCHASE ORDER NUMBER 104271			BILL OF LADING 1332-0000011180	DATE 12/30/2013	SPECIFICATION / DATE or REVISION 1-ASTM A615/A615M-09	

CHEMICAL COMPOSITION											
C %	Mn %	P %	S %	Si %	Cu %	Ni %	Cr %	Mo %	Sn %	V %	Nb %
0.41	1.09	0.024	0.034	0.22	0.39	0.15	0.24	0.040	0.009	0.003	0.000

MECHANICAL PROPERTIES					
YS PSI	YS MPa	UTS PSI	UTS MPa	G/L Inch	G/L mm
75700	522	116100	800	8.000	203.2

MECHANICAL PROPERTIES	
Elong. %	Bend Test
13.80	OK

GEOMETRIC CHARACTERISTICS			
% Light	Def Hgt Inch	Def Gap Inch	Def Space Inch
-2.75	0.051	0.160	0.496

COMMENTS / NOTES

Material 100% melted and rolled in the USA. Manufacturing processes for this steel, which may include scrap melted in an electric arc furnace and hot rolling, have been performed at Gerdau St. Paul Mill, 1678 Red Rock Rd, St. Paul, MN, USA. All product produced from strand cast billets. Silicon killed (deoxidized) steel. No weld repairment performed. Steel not exposed to mercury or any liquid alloy which is liquid at ambient temperatures during processing or while in Gerdau St. Paul Mill's possession. Any modification to this certification as provided by Gerdau-St. Paul Mill without the expressed written consent of Gerdau St. Paul Mill negates the validity of this test report. This report shall not be reproduced except in full, without the expressed written consent of Gerdau St. Paul Mill. Gerdau St. Paul Mill is not responsible for the inability of this material to meet specific applications.

Roll batch 62133268/02 roll dtd 11/26/2013

The above figures are certified chemical and physical test records as contained in the permanent records of company. This material, including the billets, was melted and manufactured in the USA. CMTR complies with EN 10204 3.1.

Bhaskar BHASKAR YALAMANCHILI
QUALITY DIRECTOR

M B ALEA BRANDENBURG
QUALITY ASSURANCE MGR.

211

Figure A-29. Long-Bent Rebar, Test Nos. SFH-1 through SFH-3

MATERIAL TEST REPORT
 Date Printed: 23-DEC-13

Date Shipped: 23-DEC-13	Product: DEF #4 (1/2")	Specification: ASTM A-706/A-615
FWIP: 52815348	Customer: CONCRETE INDUSTRIES INC	Cust. PO: 104050

Heat Number	CHEMICAL ANALYSIS															
	C	Mn	P	S	Si	Cu	Ni	Cr	Mo	Al	V	B	Cb	Sn	N	Ti
566673	0.28	1.22	0.006	0.014	0.27	0.24	0.08	0.11	0.019	0.003	0.038	0.0005	0.000	0.011	0.0086	0.001
Carbon Equivalent = 0.500																

Heat Number	Sample No.	MECHANICAL PROPERTIES					Bend	Wt/ft
		Yield (Psi)	Ultimate (Psi)	Elongation (%)	Reduction (%)			
566673	01	0.2% offset	69317	95280	16.0	ok	0.677	
		(MPa)	477.9	656.9				
566673	02	0.0035 EUL	62581	97040	16.1	ok	0.677	
		(MPa)	431.5	669.1				

All melting and manufacturing processes of the material subject to this test certificate occurred in the United States of America.
 ERMS also certifies this material to be free from Mercury contamination.
 This material has been produced and tested in accordance with the requirements of the applicable specifications. We hereby certify that the above test results represent those contained in the records of the Company.

Mark Espaner

Quality Assurance Department

FROM SHIPPING WEST (NON) DEC 23 2013 15:50/ST. 15:50/NO. 75272995Z P. 9

Figure A-30. Concrete Beam Reinforcement, Test Nos. SFH-1 through SFH-3



US-ML-ST PAUL
1678 RED ROCK ROAD
SAINT PAUL, MN 55119
USA

CERTIFIED MATERIAL TEST REPORT

CUSTOMER SHIP TO NEBCO INC STEEL DIVISION HAVELOCK, NE 68529 USA		CUSTOMER BILL TO CONCRETE INDUSTRIES INC LINCOLN, NE 68529-0529 USA		GRADE 60 (420)	SHAPE / SIZE Rebar / #6 (19MM)	
SALES ORDER 707645/000010		CUSTOMER MATERIAL N°		LENGTH 60'00"	WEIGHT 56,687 LB	HEAT / BATCH 62133268/02
CUSTOMER PURCHASE ORDER NUMBER 104271			BILL OF LADING 1332-0000011180	DATE 12/30/2013	SPECIFICATION / DATE or REVISION 1-ASTM A615/A615M-09	

CHEMICAL COMPOSITION											
C %	Mn %	P %	S %	Si %	Cu %	Ni %	Cr %	Mo %	Sn %	V %	Nb %
0.41	1.09	0.024	0.034	0.22	0.39	0.15	0.24	0.040	0.009	0.003	0.000

MECHANICAL PROPERTIES					
YS PSI	YS MPa	UTS PSI	UTS MPa	G/L Inch	G/L mm
75700	522	116100	800	8.000	203.2

MECHANICAL PROPERTIES	
Elong. %	Bend Test
13.80	OK

GEOMETRIC CHARACTERISTICS			
% Light	Def Hgt Inch	Def Gap Inch	Def Space Inch
-2.75	0.051	0.160	0.496

COMMENTS / NOTES

Material 100% melted and rolled in the USA. Manufacturing processes for this steel, which may include scrap melted in an electric arc furnace and hot rolling, have been performed at Gerdau St. Paul Mill, 1678 Red Rock Rd, St. Paul, MN, USA. All product produced from strand cast billets. Silicon killed (deoxidized) steel. No weld repairment performed. Steel not exposed to mercury or any liquid alloy which is liquid at ambient temperatures during processing or while in Gerdau St. Paul Mill's possession. Any modification to this certification as provided by Gerdau-St. Paul Mill without the expressed written consent of Gerdau St. Paul Mill negates the validity of this test report. This report shall not be reproduced except in full, without the expressed written consent of Gerdau St. Paul Mill. Gerdau St. Paul Mill is not responsible for the inability of this material to meet specific applications.

Roll batch 62133268/02 roll dtd 11/26/2013

The above figures are certified chemical and physical test records as contained in the permanent records of company. This material, including the billets, was melted and manufactured in the USA. CMTR complies with EN 10204 3.1.

Bhaskar BHASKAR YALAMANCHILI
QUALITY DIRECTOR

M B ALEA BRANDENBURG
QUALITY ASSURANCE MGR.

213

Figure A-31. Concrete Beam Reinforcement, Test Nos. SFH-1 through SFH-3

Appendix B. Vehicle Center of Gravity Determination

Test: SFH-1 Vehicle: Ram 1500 QC

Vehicle CG Determination

VEHICLE	Equipment	Weight (lb)	Vert CG (in.)	Vert M (lb-in.)
+	Unbalasted Truck (Curb)	5094	28.8785	147107.1
+	Brake receivers/wires	6	52	312
+	Brake Frame	13	25	325
+	Brake Cylinder (Nitrogen)	22	27	594
+	Strobe/Brake Battery	6	31	186
+	Hub	27	14.1875	383.0625
+	CG Plate (Sensors)	17	32	544
-	Battery	-42	40	-1680
-	Oil	-7	18	-126
-	Interior	-62	23	-1426
-	Fuel	-161	21	-3381
-	Coolant	-13	37	-481
-	Washer fluid			0
BALLAST	Water	120	21	2520
	Misc.			0
	Misc.			0
				144877.1

Estimated Total Weight (lb)	5020
Vertical CG Location (in.)	28.85999

wheel base (in.)	140.25		
MASH Targets	Targets	Test Inertial	Difference
Test Inertial Weight (lb)	5000 ± 110	5021	21.0
Long CG (in.)	63 ± 4	63.60	0.60272
Lat CG (in.)	NA	-0.32163	NA
Vert CG (in.)	≥ 28	28.86	0.85999

Note: Long. CG is measured from front axle of test vehicle
Note: Lateral CG measured from centerline - positive to vehicle right (passenger) side

CURB WEIGHT (lb)		
	Left	Right
Front	1433	1386
Rear	1133	1142
FRONT	2819 lb	
REAR	2275 lb	
TOTAL	5094 lb	

TEST INERTIAL WEIGHT (lb)		
(from scales)		
	Left	Right
Front	1366	1378
Rear	1160	1117
FRONT	2744 lb	
REAR	2277 lb	
TOTAL	5021 lb	

Figure B-1. Vehicle Mass Distribution, Test No. SFH-1

Test: SFH-2

Vehicle: RIO

Vehicle CG Determination

VEHICLE	Equipment	Weight (lb)
+	Unbalasted Car (curb)	2406
+	Brake receivers/wires	7
+	Brake Frame	9
+	Brake Cylinder	22
+	Strobe Battery	6
+	Hub	20
+	CG Plate (Data Units)	12
+		0
-	Battery	-35
-	Oil	-5
-	Interior	-39
-	Fuel	0
-	Coolant	-7
-	Washer fluid	0
BALLAST	Water	
	Misc.	
	Misc.	

Estimated Total Weight 2396 lb

wheel base 95.25 in.

MASH targets		Test Inertial	Difference
Test Inertial Wt (lb)	2420 (+/-)55	2406	-14.0
Long CG (in.)	39 (+/-)4	36.26	-2.73691
Lateral CG (in.)	N/A	0.344607	NA

Note: Long. CG is measured from front axle of test vehicle

Note: Lateral CG measured from centerline - positive to vehicle right (passenger) side

CURB WEIGHT (lb)		
	Left	Right
Front	785	748
Rear	443	430
FRONT	1533 lb	
REAR	873 lb	
TOTAL	2406 lb	

Dummy = 166lbs.

TEST INERTIAL WEIGHT (lb)		
(from scales)		
	Left	Right
Front	733	757
Rear	459	457
FRONT	1490 lb	
REAR	916 lb	
TOTAL	2406 lb	

Figure B-2. Vehicle Mass Distribution, Test No. SFH-2

Test: SFH-3 Date: 3/13/2015 Vehicle: Ford F-800

Vehicle CG Determination

VEHICLE	Equipment	Weight (lb)	Vert CG (in.)	Vert M (lb-in.)	
+	Unbalasted Truck(Curb)	11180	39.29596	439328.8	
+	Brake receivers/wires	6	88	528	
+	Brake Frame	7	42	294	
+	Brake Cylinder (Nitrogen)	28	42	1176	
+	Strobe/Brake Battery	6	40	240	
+	Hub	40	0	0	
+	Tow Pin Plate	20	0	0	
+	Cab DAS Units & Plate	2	42	84	
+	DTS Unit	17	38.5	654.5	
+	CG DAS Units & Enclosure	43	37.75	1623.25	
-	Battery	-114	28	-3192	
-	Oil	-24	18	-432	
-	Interior	-86	37	-3182	
-	Fuel	-185	21	-3885	
-	Coolant	-10	44	-440	
-	Washer fluid	-7	35	-245	
BALLAST	+	Round Plates Right	191	50	9550
	+	Rectangle Plates Right	264	49	12936
	+	Barrier Right	4934	63.25	312075.5
	+	Barrier Left	4843	63.75	308741.3
	+	Round Plates Left	191	50	9550
	+	Rectangle Plates Left	231	49	11319
	+	Ballast Hardware	205	46.5	9532.5
		Misc.			0

Ballast Weight (lb): 10859 673704.3 Ballast
Estimated Total Weight (lb): 21782
Vertical CG location (in.): 50.78766 1106257 Total

Wheel Base (in.): 171.50

MASH Targets	Targets	CURRENT	Difference
Test Inertial Weight (lb)	22,046 ± 660	21746	-300.0
Long CG (in.)	NA	119.21	NA
Lat CG (in.)	NA	-0.98	NA
Vert CG (in.)	NA	50.79	NA
Ballast CG (in.)	63 ± 2	62.04	-0.95891

Note: Long. CG is measured from front axle of test vehicle
Note: Lateral CG measured from centerline - positive to vehicle right (passenger) side

Curb Weight (lb)	
	Left Right
Front	2654 2652
Rear	3066 2808
FRONT	5306 lb
REAR	5874 lb
TOTAL	11180 lb

Actual test inertial weight (lb)	
(from scales)	
	Left Right
Front	3327 3303
Rear	7809 7307
FRONT	6630 lb
REAR	15116 lb
TOTAL	21746 lb

Figure B-3. Vehicle Mass Distribution, Test No. SFH-3

Appendix C. Vehicle Deformation Records

VEHICLE PRE/POST CRUSH
FLOORPAN - SET 1

TEST: SFH-1
VEHICLE: Ram 1500 QC

Note: If impact is on driver side need to enter negative number for Y

POINT	X (in.)	Y (in.)	Z (in.)	X' (in.)	Y' (in.)	Z' (in.)	ΔX (in.)	ΔY (in.)	ΔZ (in.)
1	28 3/4	-27 3/4	-2 3/4	28 1/2	-27 1/4	-2 1/2	- 1/4	1/2	1/4
2	31	-24 1/2	-2 1/2	31	-24 1/4	-2 1/4	0	1/4	1/4
3	32 1/2	-21 1/4	-3 1/4	32 1/2	-20 3/4	-3	0	1/2	1/4
4	32 3/4	-16 1/2	-2 3/4	32 3/4	-16	-2 1/2	0	1/2	1/4
5	27	-28	-5 1/2	27	-28	-5 1/4	0	0	1/4
6	26 3/4	-24	-6 1/4	26 3/4	-23 3/4	-6	0	1/4	1/4
7	26 3/4	-19 1/4	-6	26 3/4	-19	-5 1/2	0	1/4	1/2
8	26 3/4	-12	-5 1/4	26 3/4	-12 3/4	-4 3/4	0	- 3/4	1/2
9	24	-28 3/4	-8	24	-29	-7 3/4	0	- 1/4	1/4
10	23 3/4	-24 1/4	-7 3/4	23 3/4	-24 1/4	-7 1/2	0	0	1/4
11	23 3/4	-18 3/4	-7 3/4	23 1/2	-19	-7 1/4	- 1/4	- 1/4	1/2
12	23 3/4	-12 1/2	-7	23 3/4	-12 1/2	-6 3/4	0	0	1/4
13	17	-27 1/4	-9 1/2	17 1/4	-27 3/4	-9 1/2	1/4	- 1/2	0
14	17	-22	-9 1/4	17	-22	-9	0	0	1/4
15	17	-14 1/4	-8 3/4	17	-14 1/2	-8 1/2	0	- 1/4	1/4
16	14	-3 1/2	-1	14	-3 3/4	- 3/4	0	- 1/4	1/4
17	11 1/4	-27 1/2	-9 1/2	11 1/4	-28	-9 1/4	0	- 1/2	1/4
18	11 1/4	-22 1/4	-9	11 1/4	-22 1/2	-8 3/4	0	- 1/4	1/4
19	11 1/2	-14 1/4	-8 1/2	11 1/4	-14 1/4	-8 1/4	- 1/4	0	1/4
20	7 3/4	-2 1/4	-1 1/4	7 3/4	-2 1/4	-1 1/4	0	0	0
21	6 1/2	-26 1/2	-9 1/4	6	-26	-9	- 1/2	1/2	1/4
22	6 1/2	-16 3/4	-8 3/4	6 1/4	-16 1/2	-8 1/2	- 1/4	1/4	1/4
23	3/4	-27 1/4	-5 1/4	3/4	-27 1/4	-5	0	0	1/4
24	3/4	-21 1/4	-4 3/4	3/4	-21	-4 1/2	0	1/4	1/4
25	3/4	-14 1/2	-4 1/2	3/4	-14 1/2	-4 1/4	0	0	1/4
26	1 1/4	-4	-1 1/4	1 1/4	-4	-1	0	0	1/4
27							0	0	0
28							0	0	0
29							0	0	0
30							0	0	0
31							0	0	0

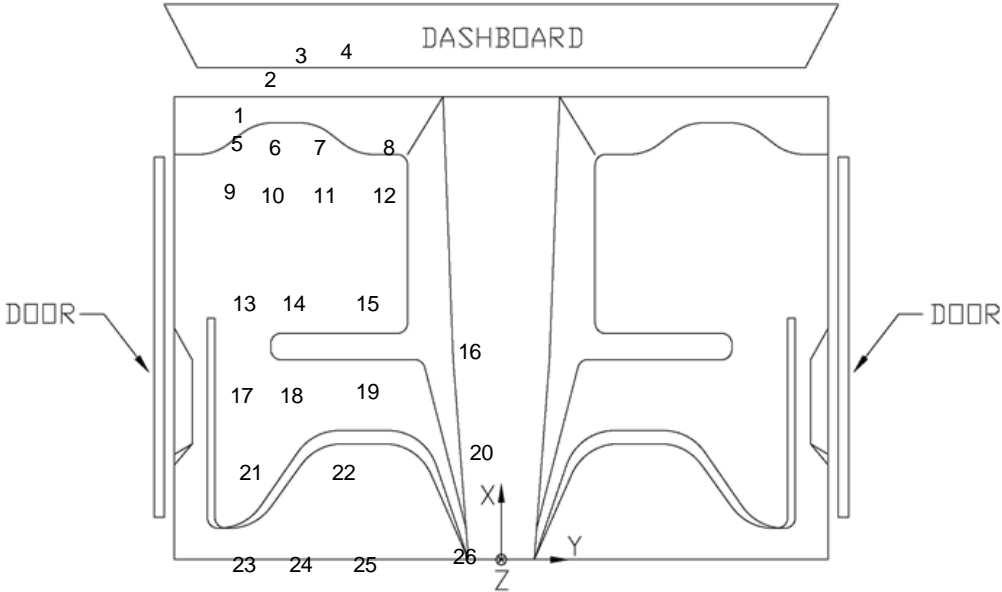

Figure C-1. Floorpan Deformation Data – Set 1, Test No. SFH-1

VEHICLE PRE/POST CRUSH
FLOORPAN - SET 2

TEST: SFH-1
VEHICLE: Ram 1500 QC

Note: If impact is on driver side need to enter negative number for Y

POINT	X (in.)	Y (in.)	Z (in.)	X' (in.)	Y' (in.)	Z' (in.)	ΔX (in.)	ΔY (in.)	ΔZ (in.)
1	44 3/4	-21 1/2	-1 1/2	44 1/2	-21	-1 1/2	-1/4	1/2	0
2	47	-18	-1 1/2	46 3/4	-18	-1 1/2	-1/4	0	0
3	48 1/2	-14 1/2	-2 1/2	48 1/4	-15	-2 1/2	-1/4	-1/2	0
4	48 3/4	-9 3/4	-2 1/4	48 3/4	-10	-2	0	-1/4	1/4
5	43	-22	-4 1/2	43	-21 1/2	-4 1/4	0	1/2	1/4
6	42 3/4	-17 1/4	-5 1/4	43	-17 1/2	-5 1/4	1/4	-1/4	0
7	42 3/4	-12	-5 1/4	43	-12 1/2	-5	1/4	-1/2	1/4
8	43	-4 3/4	-5	43	-5 1/4	-4 3/4	0	-1/2	1/4
9	40	-23	-6 3/4	40	-22 1/2	-6 1/2	0	1/2	1/4
10	40	-17 3/4	-6 3/4	39 3/4	-17 1/2	-6 1/2	-1/4	1/4	1/4
11	40	-12	-6 3/4	39 3/4	-12 1/4	-6 3/4	-1/4	-1/4	0
12	40	-6	-6 3/4	39 3/4	-6 1/4	-6 3/4	-1/4	-1/4	0
13	33 1/4	-21 3/4	-8 1/2	33 1/4	-21 1/4	-8 1/2	0	1/2	0
14	33 1/4	-14 1/4	-8 1/2	33 1/4	-15	-8 1/2	0	-3/4	0
15	33 1/4	-8	-8 1/2	33 1/4	-7 3/4	-8 1/4	0	1/4	1/4
16	30	3	-1 1/2	30	3	-1 1/4	0	0	1/4
17	27 1/4	-21 1/2	-8 1/4	27 1/4	-22	-8 1/4	0	-1/2	0
18	27 1/4	-15 1/2	-8 1/4	27 1/4	-16 1/4	-8 1/4	0	-3/4	0
19	27	-8	-8 1/4	27 1/2	-8	-8	1/2	0	1/4
20	23 3/4	4 1/2	-2 1/4	23 3/4	4 1/2	-2	0	0	1/4
21	22 1/4	-20	-8 1/2	22	-20	-8 1/2	-1/4	0	0
22	22	-9 3/4	-8 1/2	22 1/4	-10 1/4	-8 1/4	1/4	-1/2	1/4
23	16 3/4	-20 3/4	-4 1/2	17	-20 3/4	-4 1/4	1/4	0	1/4
24	16 3/4	-14 1/2	-4 1/4	16 3/4	-14 1/2	-4 1/4	0	0	0
25	16 3/4	-8	-4 1/4	16 3/4	-7 3/4	-4 1/4	0	1/4	0
26	17 1/4	2 3/4	-1 3/4	17 1/4	2 3/4	-1 1/2	0	0	1/4
27							0	0	0
28							0	0	0
29							0	0	0
30							0	0	0
31							0	0	0

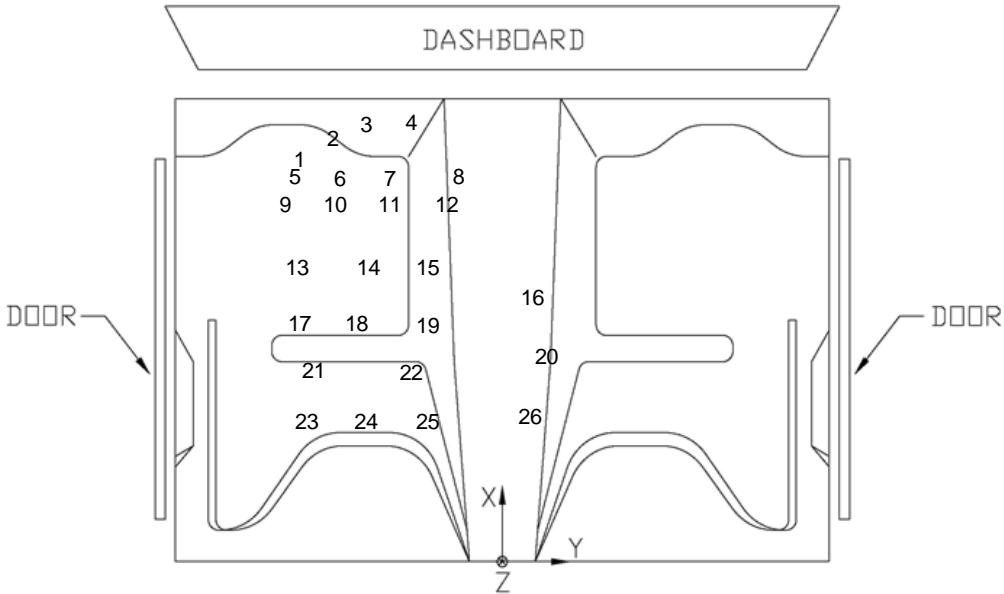

Figure C-2. Floorpan Deformation Data – Set 2, Test No. SFH-1

VEHICLE PRE/POST CRUSH
INTERIOR CRUSH - SET 1

TEST: SFH-1
VEHICLE: Ram 1500 QC

Note: If impact is on driver side need to enter negative number for Y

	POINT	X (in.)	Y (in.)	Z (in.)	X' (in.)	Y' (in.)	Z' (in.)	ΔX (in.)	ΔY (in.)	ΔZ (in.)
DASH	A1	55 1/4	-58	23 1/4	55 1/4	-58	23 1/2	0	0	1/4
	A2	53	-42	25 3/4	53	-42	26	0	0	1/4
	A3	52 1/4	-34 1/2	25 3/4	52	-34 1/2	26	- 1/4	0	1/4
	A4	50 3/4	-61	13 1/2	50 1/2	-60 1/2	13 1/2	- 1/4	1/2	0
	A5	48 1/2	-46	15	48 1/2	-46	15	0	0	0
	A6	46 3/4	-40	15	46 1/4	-40	15	- 1/2	0	0
SIDE PANEL	B1	26	-27 1/4	- 1/2	26	-27 1/4	- 1/2	0	0	0
	B2	21 1/2	-26 1/4	1 3/4	21 1/4	-25 3/4	2	- 1/4	1/2	1/4
	B3	20 3/4	-26 1/4	-4	20 3/4	-26 1/4	-4	0	0	0
IMPACT SIDE DOOR	C1	8	-41	17 1/2	8 1/4	-41 1/4	17 1/4	1/4	- 1/4	- 1/4
	C2	16 3/4	-40 3/4	17	16 1/4	-41	17	- 1/2	- 1/4	0
	C3	27 1/4	-40 1/4	16 1/2	26 3/4	-40	16 1/2	- 1/2	1/4	0
	C4	6 1/2	-35	2 3/4	6 1/4	-36	2 3/4	- 1/4	-1	0
	C5	19 1/2	-34 3/4	-1 3/4	19	-35	-1 1/2	- 1/2	- 1/4	1/4
	C6	27	-34 1/2	3/4	26	-34 1/2	1	-1	0	1/4
ROOF	D1							0	0	0
	D2							0	0	0
	D3							0	0	0
	D4							0	0	0
	D5							0	0	0
	D6							0	0	0
	D7							0	0	0
	D8							0	0	0
	D9							0	0	0
	D10							0	0	0
	D11							0	0	0
	D12							0	0	0
	D13							0	0	0
	D14							0	0	0
	D15							0	0	0

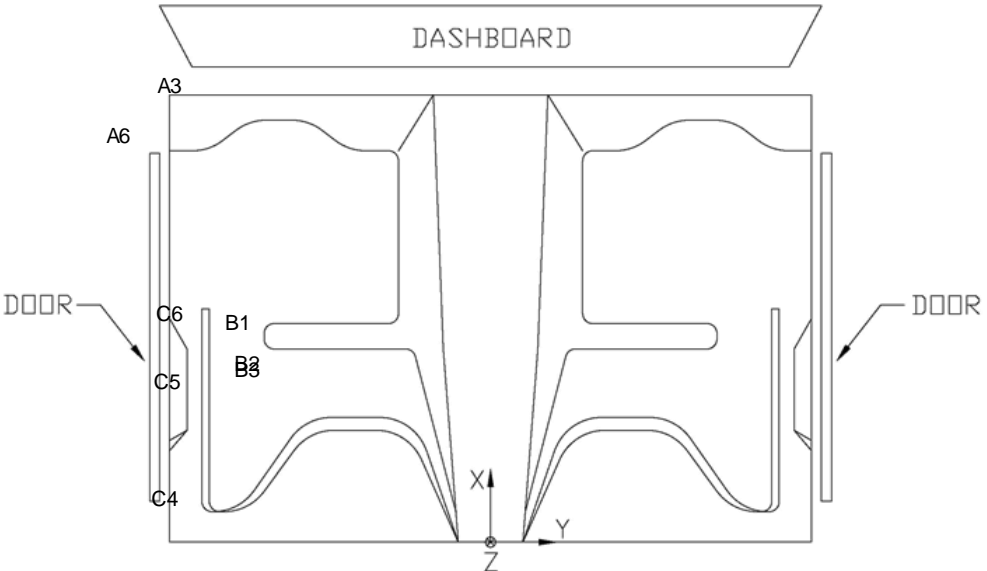

Figure C-3. Occupant Compartment Deformation Data – Set 1, Test No. SFH-1

VEHICLE PRE/POST CRUSH
INTERIOR CRUSH - SET 2

TEST: SFH-1
VEHICLE: Ram 1500 QC

Note: If impact is on driver side need to enter negative number for Y

	POINT	X (in.)	Y (in.)	Z (in.)	X' (in.)	Y' (in.)	Z' (in.)	ΔX (in.)	ΔY (in.)	ΔZ (in.)
DASH	A1	39 3/4	-58 1/2	24 1/2	40 1/4	-58 1/2	24 1/2	1/2	0	0
	A2	40 1/4	-42 1/2	26	40 3/4	-42 1/2	26	1/2	0	0
	A3	40 1/4	-34 1/2	25 1/4	40 3/4	-34 1/2	25 3/4	1/2	0	1/2
	A4	33	-60 1/2	14 1/2	33 1/4	-60 1/2	14 1/2	1/4	0	0
	A5	33 1/2	-45 3/4	15 1/4	34	-45 1/2	15 1/4	1/2	1/4	0
	A6	32 1/4	-39 1/2	14 1/2	32 3/4	-39 1/4	14 1/2	1/2	1/4	0
SIDE PANEL	B1	43 1/2	-29	1	43 1/2	-28 3/4	1	0	1/4	0
	B2	38	-27	3	38	-26 1/2	3 1/4	0	1/2	1/4
	B3	39 1/4	-26 3/4	-2 3/4	39 1/4	-26 3/4	-2 1/2	0	0	1/4
IMPACT SIDE DOOR	C1	11 1/4	-34 1/2	18 1/2	11 1/2	-34 3/4	18 1/2	1/4	-1/4	0
	C2	20 1/4	-34	18 1/4	19 3/4	-34	18 1/4	-1/2	0	0
	C3	30 1/2	-33 3/4	17 3/4	30	-33 1/4	17 3/4	-1/2	1/2	0
	C4	11 1/4	-28	3 1/2	11 1/2	-28 1/4	3 3/4	1/4	-1/4	1/4
	C5	24 3/4	-27 1/4	-1/4	24	-27 1/2	-1/4	-3/4	-1/4	0
	C6	32	-27 1/2	2 1/4	31 1/2	-27 1/2	2 1/4	-1/2	0	0
ROOF	D1							0	0	0
	D2							0	0	0
	D3							0	0	0
	D4							0	0	0
	D5							0	0	0
	D6							0	0	0
	D7							0	0	0
	D8							0	0	0
	D9							0	0	0
	D10							0	0	0
	D11							0	0	0
	D12							0	0	0
	D13							0	0	0
	D14							0	0	0
	D15							0	0	0

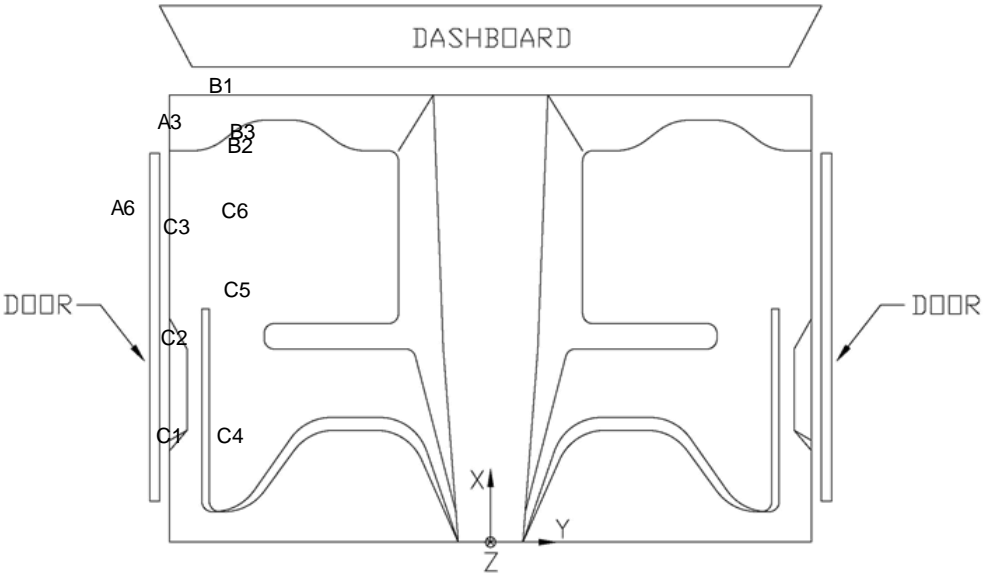

Figure C-4. Occupant Compartment Deformation Data – Set 2, Test No. SFH-1

Date: 8/26/2014

Test Number: SFH-1

Make: Dodge

Model: Ram 1500 QC

Year: 2005

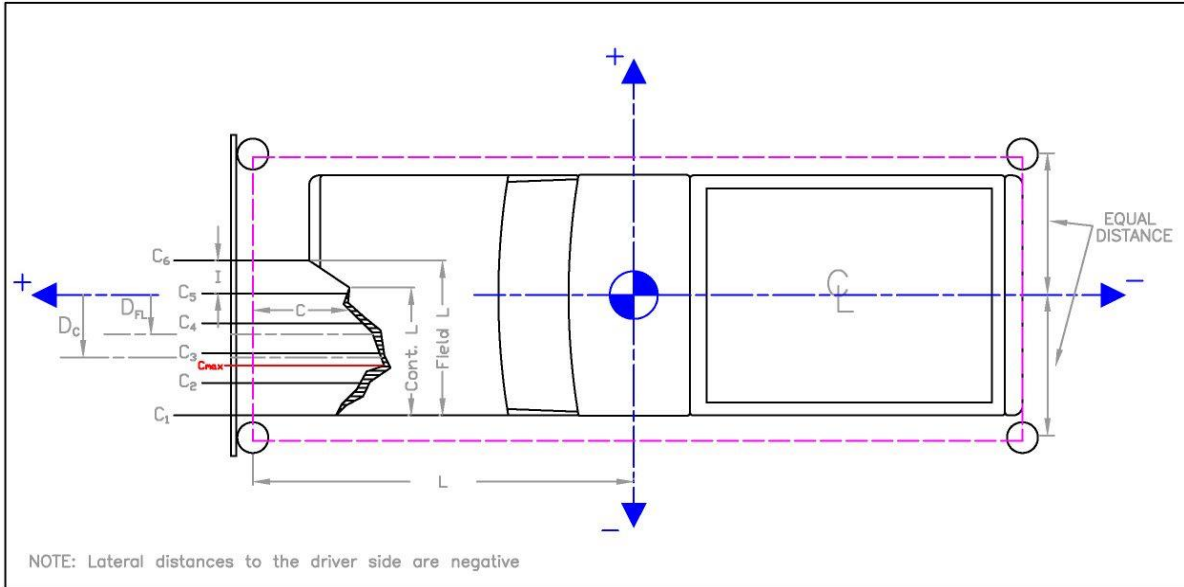

	in.	(mm)
Distance from C.G. to reference line - L _{REF} :	112	(2845)
Width of contact and induced crush - Field L:	39	(991)
Crush measurement spacing interval (L/5) - I:	7.8	(198)
Distance from center of vehicle to center of Field L - D _{FL} :	-19.5	-(495)
Width of Contact Damage:	21	(533)
Distance from center of vehicle to center of contact damage - D _C :	28 1/2	(724)

NOTE: Enter "NA" for crush measurement if distance can not be measured (i.e., side of vehicle has been pushed inward)

	Crush Measurement		Lateral Location		Original Profile Measurement		Dist. Between Ref. Lines		Actual	Crush
	in.	(mm)	in.	(mm)	in.	(mm)	in.	(mm)		
C ₁	na	NA	-39	-(991)	29	(737)	-1 1/3	-(34)	NA	NA
C ₂	na	NA	-31 1/5	-(792)	17	(431)			NA	NA
C ₃	23	(584)	-23 2/5	-(594)	13 1/2	(342)			10 8/9	(276)
C ₄	11 3/4	(298)	-15 3/5	-(396)	11 5/7	(297)			1 2/5	(36)
C ₅	9 1/4	(235)	-7 4/5	-(198)	10 1/2	(267)			1/9	(3)
C ₆	8 1/2	(216)	0	(0)	10 1/4	(260)			- 2/5	-(10)
C _{MAX}	23	(584)	-23 2/5	-(594)	13 1/2	(342)			10 8/9	(276)

Figure C-5. Exterior Vehicle Crush (NASS) - Front, Test No. SFH-1

Date: 8/26/2014 Test Number: SFH-1
Make: Dodge Model: Ram 1500 QC Year: 2005

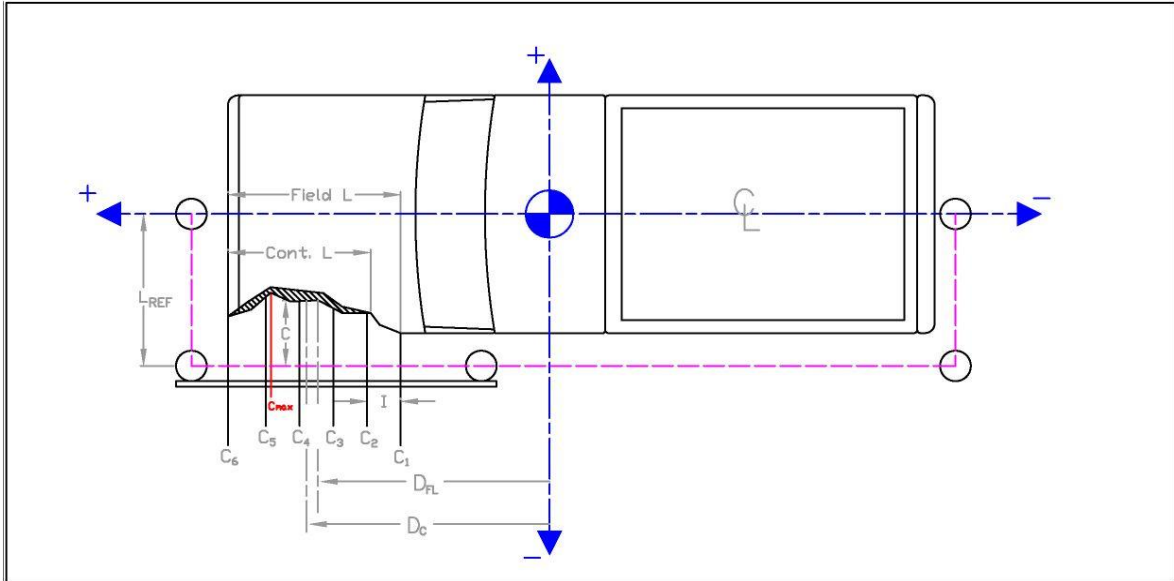

	in.	(mm)
Distance from centerline to reference line - L _{REF} :	<u>46</u>	<u>(1168)</u>
Width of contact and induced crush - Field L:	<u>227 3/4</u>	<u>(5785)</u>
Crush measurement spacing interval (L/5) - I:	<u>45.55</u>	<u>(1157)</u>
Distance from vehicle c.g. to center of Field L - D _{FL} :	<u>-10.75</u>	<u>-(273)</u>
Width of Contact Damage:	<u>227 3/4</u>	<u>(5785)</u>
Distance from vehicle c.g. to center of contact damage - D _C :	<u>10 3/4</u>	<u>(273)</u>

NOTE: Enter "NA" for crush measurement if distance can not be measured (i.e., front of vehicle has been pushed inward or tire has been removed)

	Crush Measurement		Longitudinal Location		Original Profile Measurement		Dist. Between Ref. Lines		Actual	Crush
	in.	(mm)	in.	(mm)	in.	(mm)	in.	(mm)		
C ₁	<u>11 3/4</u>	<u>(298)</u>	<u>-124 5/8</u>	<u>-(3165)</u>	<u>16</u>	<u>(406)</u>	<u>-4</u>	<u>-(102)</u>	<u>- 1/4</u>	<u>-(6)</u>
C ₂	<u>9 1/4</u>	<u>(235)</u>	<u>-79</u>	<u>-(2009)</u>	<u>10 1/2</u>	<u>(267)</u>			<u>2 3/4</u>	<u>(70)</u>
C ₃	<u>7 1/2</u>	<u>(191)</u>	<u>-33 1/2</u>	<u>-(852)</u>	<u>11 5/8</u>	<u>(295)</u>			<u>- 1/8</u>	<u>-(3)</u>
C ₄	<u>6</u>	<u>(152)</u>	<u>12</u>	<u>(305)</u>	<u>11 1/4</u>	<u>(286)</u>			<u>-1 1/4</u>	<u>-(32)</u>
C ₅	<u>12</u>	<u>(305)</u>	<u>57 4/7</u>	<u>(1462)</u>	<u>10 1/2</u>	<u>(267)</u>			<u>5 1/2</u>	<u>(140)</u>
C ₆	<u>na</u>	<u>NA</u>	<u>103 1/8</u>	<u>(2619)</u>	<u>37</u>	<u>(940)</u>			<u>NA</u>	<u>NA</u>
C _{MAX}	<u>19</u>	<u>(483)</u>	<u>80</u>	<u>(2032)</u>	<u>11 1/4</u>	<u>(286)</u>			<u>11 3/4</u>	<u>(298)</u>

Figure C-6. Exterior Vehicle Crush (NASS) - Side, Test No. SFH-1

VEHICLE PRE/POST CRUSH
FLOORPAN - SET 1

TEST: SFH-2
VEHICLE: RIO

Note: If impact is on driver side need to enter negative number for Y

POINT	X (in.)	Y (in.)	Z (in.)	X' (in.)	Y' (in.)	Z' (in.)	ΔX (in.)	ΔY (in.)	ΔZ (in.)
F1	26	-21 3/4	1 1/4	24 3/4	-21	1 1/4	-1 1/4	3/4	0
2	27 3/4	-18	0	26	-17 1/4	0	-1 3/4	3/4	0
3	31 1/4	-14 3/4	1	28 3/4	-14 1/4	1	-2 1/2	1/2	0
4	31 1/4	-7 3/4	1/2	31	-8 1/4	1/4	-1/4	-1/2	-1/4
5	24 3/4	-22 1/2	-2 1/2	24	-21 3/4	-2 1/4	-3/4	3/4	1/4
6	27 1/4	-17 3/4	-2 1/2	26	-17 3/4	-2 1/2	-1 1/4	0	0
7	26 3/4	-13	-4 1/2	26 1/4	-14	-5 1/2	-1/2	-1	-1
8	27 1/4	-8	-4 1/2	27 1/4	-8 1/2	-5 1/4	0	-1/2	-3/4
9	22	-21 3/4	-6 1/4	22 1/4	-22	-6 3/4	1/4	-1/4	-1/2
10	23	-17	-6 1/4	22 3/4	-16 3/4	-6 1/4	-1/4	1/4	0
11	21 1/2	-13	-6 1/2	21 1/2	-13	-7 1/4	0	0	-3/4
12	21 1/2	-7	-7 1/4	21 3/4	-6 1/2	-7 3/4	1/4	1/2	-1/2
13	18 1/4	-22 1/2	-6 1/2	18 1/4	-22 3/4	-6 1/2	0	-1/4	0
14	19 1/4	-17	-6 3/4	19	-17	-7 1/4	-1/4	0	-1/2
15	19	-13	-6 3/4	19 1/4	-13 1/4	-7 1/2	1/4	-1/4	-3/4
16	18 3/4	-7	-7 1/4	18 3/4	-7 1/4	-7 3/4	0	-1/4	-1/2
17	15 1/4	-20 1/2	-6 3/4	15 1/4	-20 1/2	-7	0	0	-1/4
18	15	-15	-6 3/4	15	-15 1/4	-7 1/2	0	-1/4	-3/4
19	14 3/4	-10	-7	14 3/4	-10 1/4	-7 1/4	0	-1/4	-1/4
20	15	-4 1/4	-7 1/4	15	-4 3/4	-7 1/2	0	-1/2	-1/4
21	11 3/4	-20 3/4	-6 3/4	11 1/2	-20 3/4	-7	-1/4	0	-1/4
22	11 1/4	-14	-7	11 1/4	-14 1/4	-7 1/2	0	-1/4	-1/2
23	11	-7 3/4	-7 1/2	10 3/4	-8	-7 1/2	-1/4	-1/4	0
24	10	-0.25	-3 1/4	10	-1/2	-3	0	-1/4	1/4
25	2	-21 1/4	-3 3/4	2	-21 1/2	-3 3/4	0	-1/4	0
26	1 3/4	-16 1/2	-4 1/2	1 3/4	-16 1/2	-4 1/2	0	0	0
27	1 1/2	-10	-4 3/4	1 3/4	-9 3/4	-4 3/4	1/4	1/4	0
28	2 3/4	-1/2	-3 1/4	2 1/2	-1/2	-3	-1/4	0	1/4
29							0	0	0
30							0	0	0
31							0	0	0

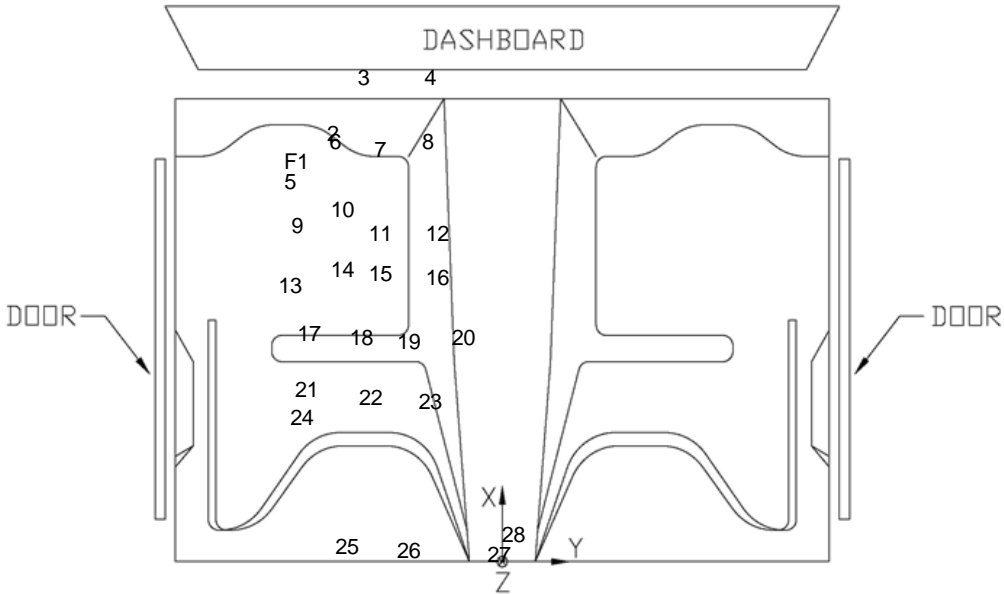

Figure C-7. Floorpan Deformation Data – Set 1, Test No. SFH-2

VEHICLE PRE/POST CRUSH
FLOORPAN - SET 2

TEST: SFH-2
VEHICLE: RIO

Note: If impact is on driver side need to enter negative number for Y

POINT	X (in.)	Y (in.)	Z (in.)	X' (in.)	Y' (in.)	Z' (in.)	ΔX (in.)	ΔY (in.)	ΔZ (in.)
1	35 1/2	-28	1	34 1/4	-27 1/2	1 1/2	-1 1/4	1/2	1/2
2	37 1/4	-24 1/4	0	35 3/4	-24 1/2	1/4	-1 1/2	- 1/4	1/4
3	40 3/4	-20 1/2	1	38 1/4	-20 3/4	1 1/4	-2 1/2	- 1/4	1/4
4	41	-14	1	40 3/4	-14 1/2	3/4	- 1/4	- 1/2	- 1/4
5	34 1/2	-28	-2 1/2	33 3/4	-27 3/4	-2 1/4	- 3/4	1/4	1/4
6	36 3/4	-23 1/2	-2 1/2	35 3/4	-24	-2 1/2	-1	- 1/2	0
7	36 1/2	-19	-4 1/4	36 1/4	-19 3/4	-5	- 1/4	- 3/4	- 3/4
8	37 1/4	-13 3/4	-4 1/4	37 1/4	-14	-4 1/2	0	- 1/4	- 1/4
9	32	-27 3/4	-6 1/4	32	-27 1/2	-6 3/4	0	1/4	- 1/2
10	32 3/4	-22 1/2	-6	32 3/4	-23 1/4	-6 1/2	0	- 3/4	- 1/2
11	31 1/2	-19 1/4	-6 1/4	31 1/2	-19	-6 3/4	0	1/4	- 1/2
12	31 3/4	-13	-6 3/4	31 3/4	-13 1/2	-7 1/4	0	- 1/2	- 1/2
13	28	-28 1/2	-6 1/2	28	-28 3/4	-6 1/2	0	- 1/4	0
14	29	-23	-6 1/2	29	-23 1/4	-7	0	- 1/4	- 1/2
15	29 1/4	-18 3/4	-6 1/2	29 1/4	-18 3/4	-7	0	0	- 1/2
16	28 3/4	-13	-6 3/4	28 3/4	-13 3/4	-7 1/4	0	- 3/4	- 1/2
17	25	-26 3/4	-6 1/2	25	-26 1/2	-6 3/4	0	1/4	- 1/4
18	25	-20 3/4	-6 1/2	25	-21 1/4	-7	0	- 1/2	- 1/2
19	24 3/4	-15 3/4	-6 1/2	24 3/4	-16 1/4	-6 3/4	0	- 1/2	- 1/4
20	25	-10	-6 1/2	25	-10 1/2	-6 3/4	0	- 1/2	- 1/4
21	21 1/2	-26 2/3	-6 1/2	21 1/2	-26 3/4	-6 3/4	0	-0	- 1/4
22	21 1/4	-20 1/4	-6 1/2	21 1/4	-20 1/4	-7	0	0	- 1/2
23	21	-13 1/2	-6 3/4	21	-14	-7	0	- 1/2	- 1/4
24	20	-6 1/4	-2 1/4	20	-6 1/2	-2 1/4	0	- 1/4	0
25	11 3/4	-27 1/4	-3 1/4	11 3/4	-27 1/4	-3 1/2	0	0	- 1/4
26	11 3/4	-22 1/2	-4	11 3/4	-22 1/2	-4	0	0	0
27	11 3/4	-16	-4	11 1/2	-15 3/4	-4	- 1/4	1/4	0
28	12 1/2	-6 1/2	-2 1/4	12 1/2	-6 1/2	-2	0	0	1/4
29							0	0	0
30							0	0	0
31							0	0	0

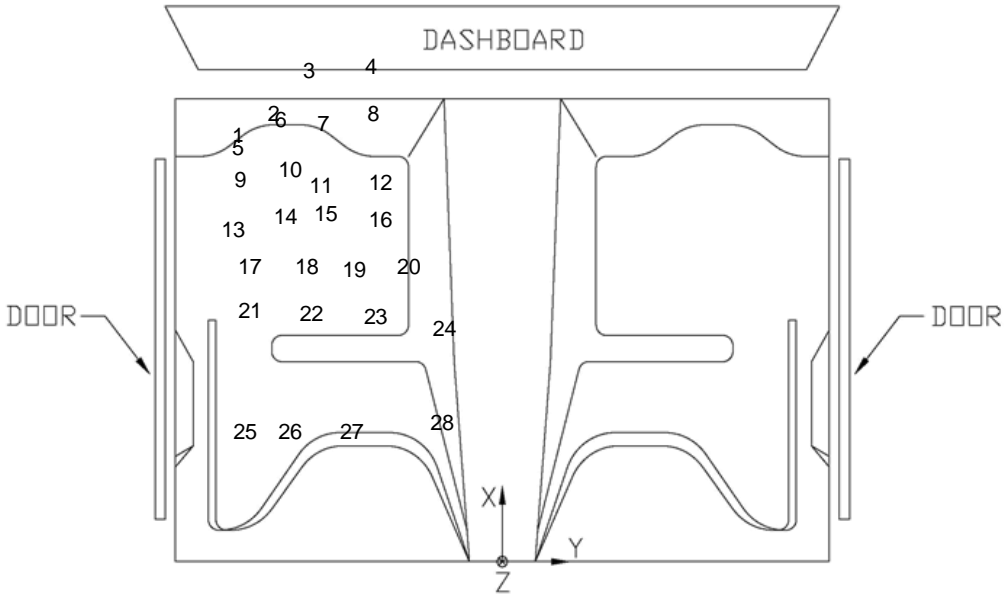

Figure C-8. Floorpan Deformation Data – Set 2, Test No. SFH-2

VEHICLE PRE/POST CRUSH
INTERIOR CRUSH - SET 1

TEST: SFH-2
VEHICLE: RIO

Note: If impact is on driver side need to enter negative number for Y

	POINT	X (in.)	Y (in.)	Z (in.)	X' (in.)	Y' (in.)	Z' (in.)	ΔX (in.)	ΔY (in.)	ΔZ (in.)
DASH	A1	34	-40 3/4	22 1/2	34	-40	23	0	3/4	1/2
	A2	33 3/4	-30 1/2	22	33 3/4	-30	22 1/4	0	1/2	1/4
	A3	32 1/2	-25 1/4	19 1/2	32 1/4	-24 3/4	20	- 1/4	1/2	1/2
	A4	29 3/4	-50 3/4	16 1/2	29 1/4	-50	16 1/2	- 1/2	3/4	0
	A5	29 1/2	-30 1/4	16 3/4	29 1/2	-29 1/2	16 3/4	0	3/4	0
	A6	29 3/4	-26 1/4	17	29 1/2	-25 1/2	17 1/4	- 1/4	3/4	1/4
SIDE PANEL	B1	19 1/4	-24 1/2	2 3/4	18 3/4	-23 1/4	2 1/2	- 1/2	1 1/4	- 1/4
	B2	17 3/4	-23 3/4	- 1/4	17 3/4	-23	- 1/4	0	3/4	0
	B3	22	-25 1/4	3 1/4	21	-24 1/4	3 1/2	-1	1	1/4
IMPACT SIDE DOOR	C1	6 1/2	-33 1/2	19 1/4	5 3/4	-35 3/4	19 1/2	- 3/4	-2 1/4	1/4
	C2	15 3/4	-33 1/4	18 3/4	14	-34 3/4	18 3/4	-1 3/4	-1 1/2	0
	C3	22 1/2	-32 3/4	18 1/2	21	-34	18 1/2	-1 1/2	-1 1/4	0
	C4	11	-27	7	9 1/2	-30 1/4	7 1/2	-1 1/2	-3 1/4	1/2
	C5	15	-27 1/4	8 1/2	13 1/2	-30	8 3/4	-1 1/2	-2 3/4	1/4
	C6	21 1/2	-27 1/2	7 3/4	20 1/4	-28 3/4	8	-1 1/4	-1 1/4	1/4
ROOF	D1							0	0	0
	D2							0	0	0
	D3							0	0	0
	D4							0	0	0
	D5							0	0	0
	D6							0	0	0
	D7							0	0	0
	D8							0	0	0
	D9							0	0	0
	D10							0	0	0
	D11							0	0	0
	D12							0	0	0
	D13							0	0	0
	D14							0	0	0
	D15							0	0	0

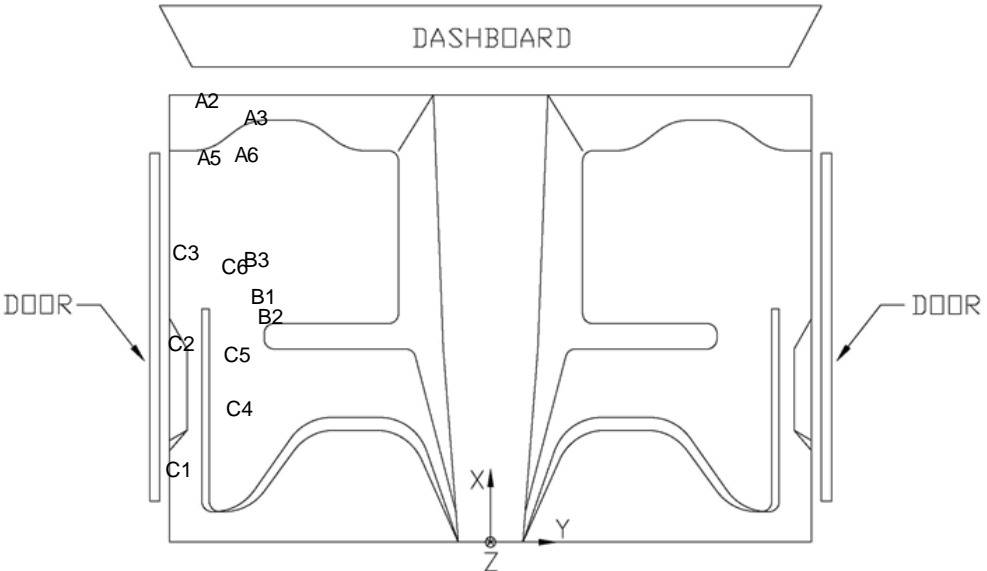

Figure C-9. Occupant Compartment Deformation Data – Set 1, Test No. SFH-2

VEHICLE PRE/POST CRUSH
INTERIOR CRUSH - SET 2

TEST: SFH-2
VEHICLE: RIO

Note: If impact is on driver side need to enter negative number for Y

	POINT	X (in.)	Y (in.)	Z (in.)	X' (in.)	Y' (in.)	Z' (in.)	ΔX (in.)	ΔY (in.)	ΔZ (in.)
DASH	A1	48 1/2	-41	23	48 1/4	-40 1/4	23 1/2	- 1/4	3/4	1/2
	A2	47 3/4	-31 1/2	22 1/2	47 1/2	-30 3/4	23	- 1/4	3/4	1/2
	A3	47	-27	20 1/2	46 3/4	-26 1/2	21	- 1/4	1/2	1/2
	A4	46	-51	16 1/2	45 1/4	-50 1/4	16 1/2	- 3/4	3/4	0
	A5	45	-31 1/2	17 1/2	44 3/4	-31	17 1/2	- 1/4	1/2	0
	A6	45	-28	18	44 1/2	-27 1/4	18 1/4	- 1/2	3/4	1/4
SIDE PANEL	B1	30	-26 1/2	2 1/2	30	-25	2 3/4	0	1 1/2	1/4
	B2	29 1/4	-26	- 1/4	29 1/4	-25	- 1/2	0	1	- 1/4
	B3	32 3/4	-28	3	32 1/4	-26 1/2	3 1/2	- 1/2	1 1/2	1/2
IMPACT SIDE DOOR	C1	11 3/4	-38 3/4	19 3/4	10 1/2	-41 1/2	20	-1 1/4	-2 3/4	1/4
	C2	20	-38 1/4	19	18 1/2	-40 1/4	19	-1 1/2	-2	0
	C3	27	-38	18 3/4	25	-39	18 1/2	-2	-1	- 1/4
	C4	15 1/2	-33 1/4	7 1/2	14 1/2	-36 1/2	7 3/4	-1	-3 1/4	1/4
	C5	19 3/4	-33 1/2	8 3/4	18 3/4	-36	9	-1	-2 1/2	1/4
	C6	26	-33 1/2	8	24 3/4	-34 3/4	8	-1 1/4	-1 1/4	0
ROOF	D1							0	0	0
	D2							0	0	0
	D3							0	0	0
	D4							0	0	0
	D5							0	0	0
	D6							0	0	0
	D7							0	0	0
	D8							0	0	0
	D9							0	0	0
	D10							0	0	0
	D11							0	0	0
	D12							0	0	0
	D13							0	0	0
	D14							0	0	0
	D15							0	0	0

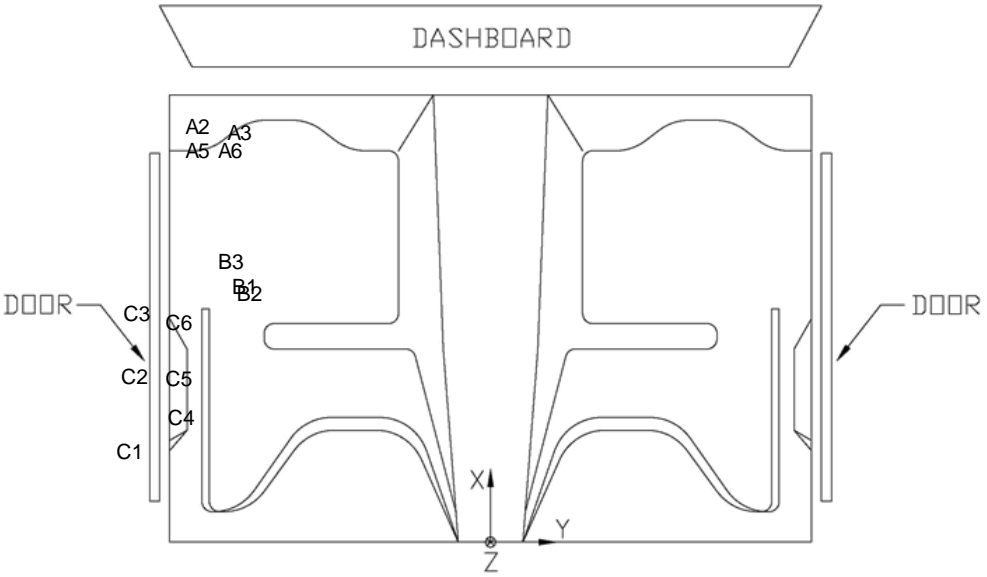

Figure C-10. Occupant Compartment Deformation Data – Set 2, Test No. SFH-2

SFH-2 Roof Crush

Comparative measurement of SFH-2 roof damage to undamaged vehicle:

SFH-2 at max point of crush	6.75"
Undamaged vehicle	<u>5.5"</u>
Total crush	1.75"

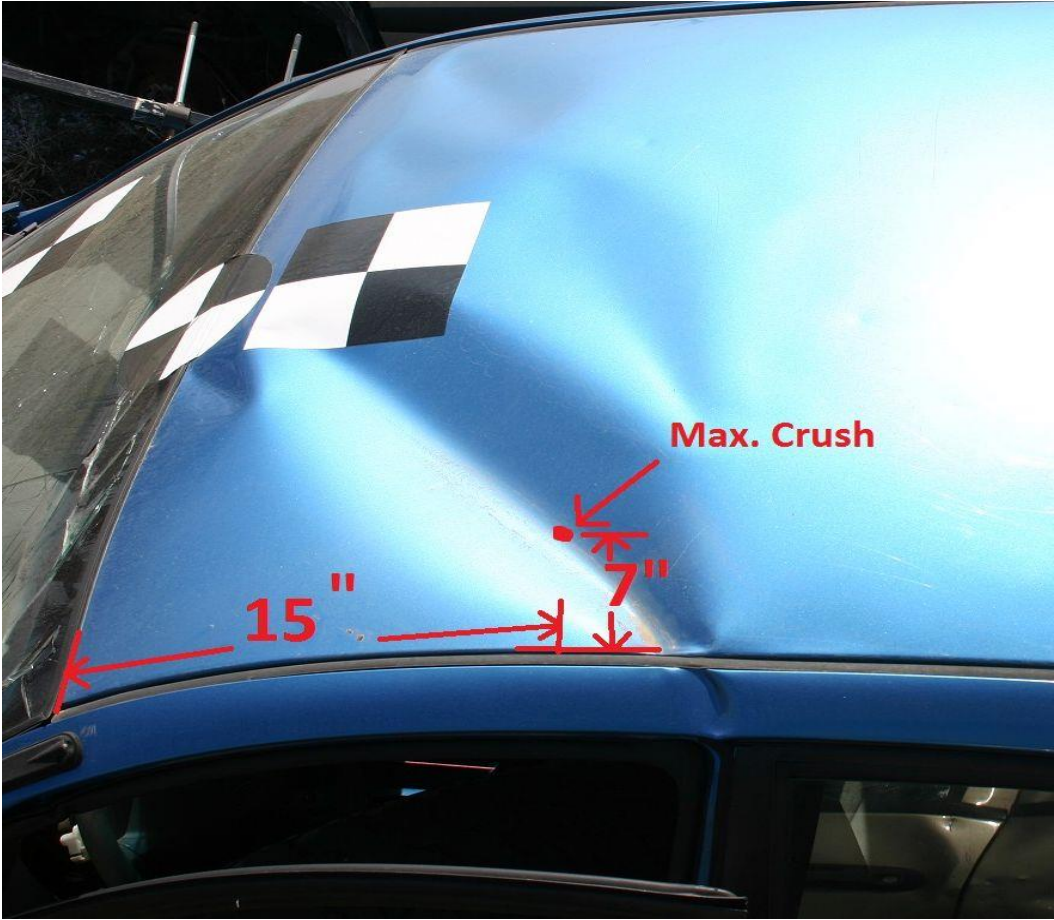
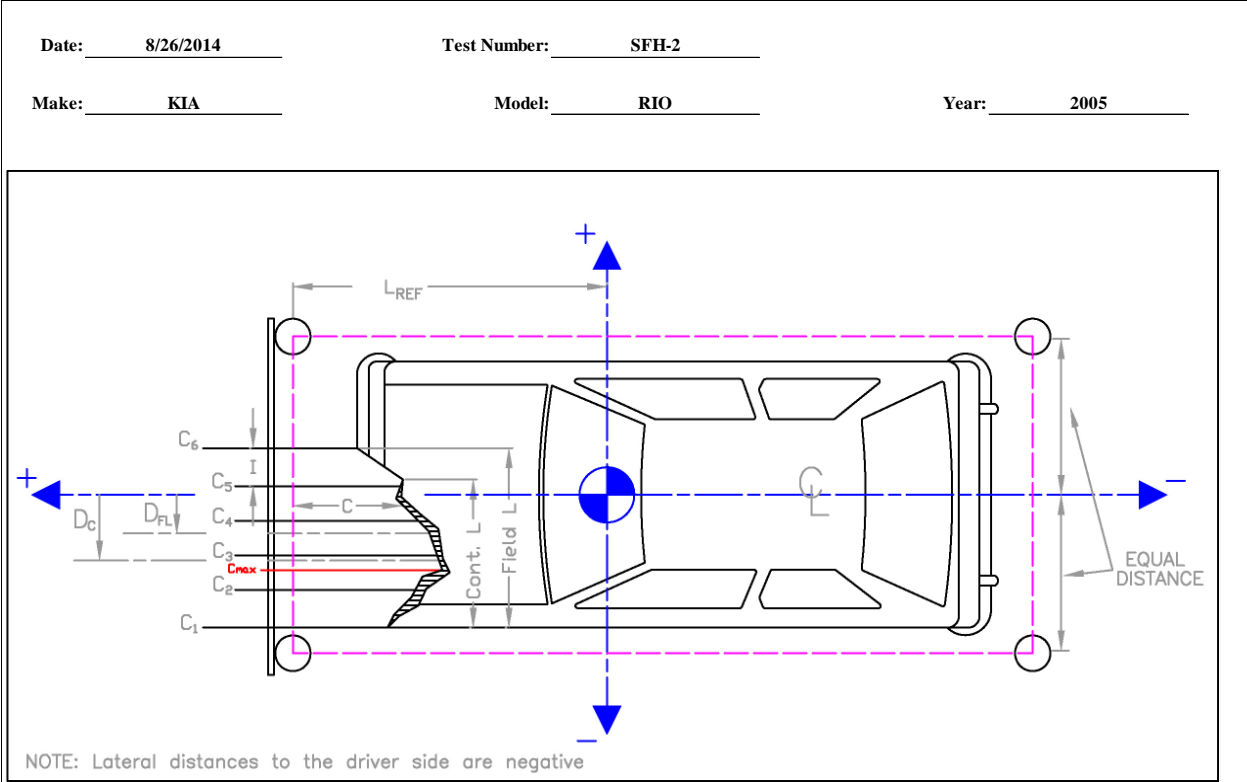

Figure C-11. Occupant Compartment Deformation Data – Roof Crush, Test No. SFH-2



	in.	(mm)
Distance from C.G. to reference line - L-REF:	81 1/4	(2064)
Width of contact and induced crush - Field L:	65 1/2	(1664)
Crush measurement spacing interval (L/5) - I:	13	(333)
Distance from center of vehicle to center of Field L - D _{FL} :	0	0
Width of Contact Damage:	65 1/2	(1664)
Distance from center of vehicle to center of contact damage - D _C :	0	0

NOTE: Enter "NA" for crush measurement if distance can not be measured (i.e., side of vehicle has been pushed inward)

	Crush Measurement		Lateral Location		Original Profile Measurement		Dist. Between Ref. Lines		Actual	Crush
	in.	(mm)	in.	(mm)	in.	(mm)	in.	(mm)		
C ₁	na	NA	-32 3/4	-(832)	24	(610)	2 3/4	(70)	NA	NA
C ₂	34	(864)	-19 2/3	-(499)	8 4/9	(215)			22 4/5	(579)
C ₃	18	(457)	-6 5/9	-(166)	6 1/6	(157)			9	(231)
C ₄	14	(356)	6 5/9	(166)	6 1/6	(156)			5 1/9	(130)
C ₅	12 1/4	(311)	19 2/3	(499)	8 2/5	(214)			1 1/9	(28)
C ₆	na	NA	32 3/4	(832)	24	(610)			NA	NA
C _{MAX}	34	(864)	-19 2/3	-(500)	8 4/9	(215)			22 4/5	(579)

Figure C-12. Exterior Vehicle Crush (NASS) - Front, Test No. SFH-2

Date: 8/26/2014

Test Number: SFH-2

Make: KIA

Model: RIO

Year: 2005

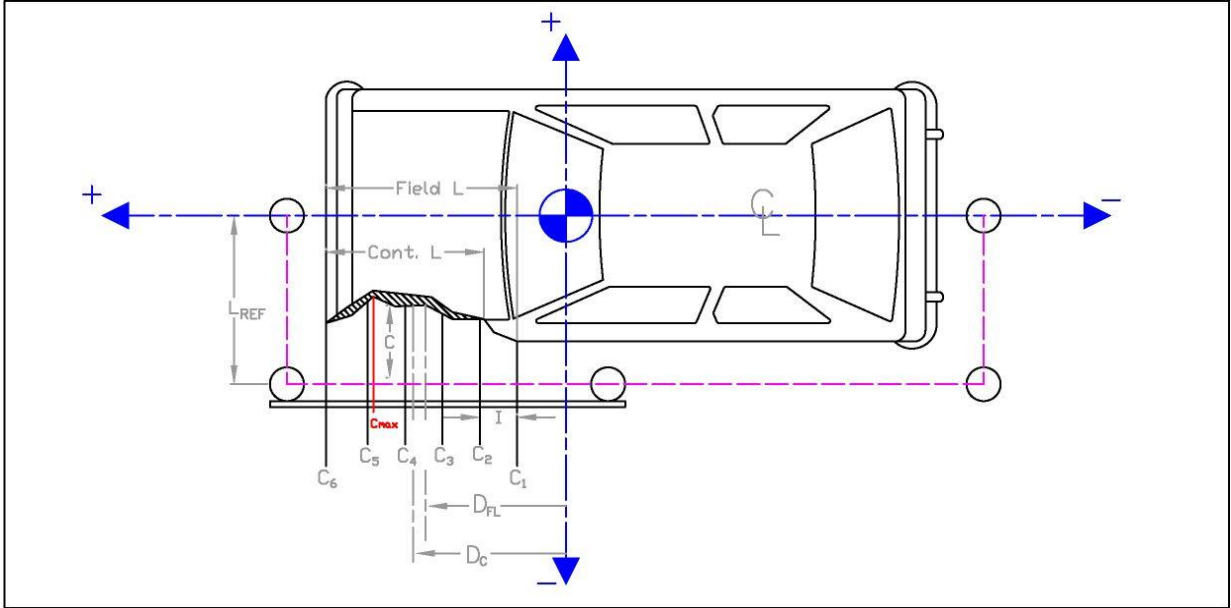

	in.	(mm)
Distance from centerline to reference line - L _{REF} :	36	(914)
Width of contact and induced crush - Field L:	166.5	(4229)
Crush measurement spacing interval (L/5) - I:	33.3	(846)
Distance from vehicle c.g. to center of Field L - D _{FL} :	-13.75	-(349)
Width of Contact Damage:	166.5	(4229)
Distance from vehicle c.g. to center of contact damage - D _C :	13.75	(349)

NOTE: Enter "NA" for crush measurement if distance can not be measured (i.e., front of vehicle has been pushed inward or tire has been removed)

	Crush Measurement		Longitudinal Location		Original Profile Measurement		Dist. Between Ref. Lines		Actual	Crush
	in.	(mm)	in.	(mm)	in.	(mm)	in.	(mm)		
C ₁	na	NA	-97	-(2464)	26.00	(660)	0	(0)	NA	NA
C ₂	5.5	(140)	-63.7	-(1618)	4.00	(102)			1.5	(38)
C ₃	3.75	(95)	-30.4	-(772)	3.63	(92)			0.1	(3)
C ₄	4.5	(114)	2.9	(74)	3.75	(95)			0.8	(19)
C ₅	8.25	(210)	36.2	(919)	3.25	(83)			5.0	(127)
C ₆	na	NA	69.5	(1765)	20.19	(513)			NA	NA
C _{MAX}	20.75	(527)	55	(1397)	4.94	(125)			15.8	(402)

Figure C-13. Exterior Vehicle Crush (NASS) - Side, Test No. SFH-2

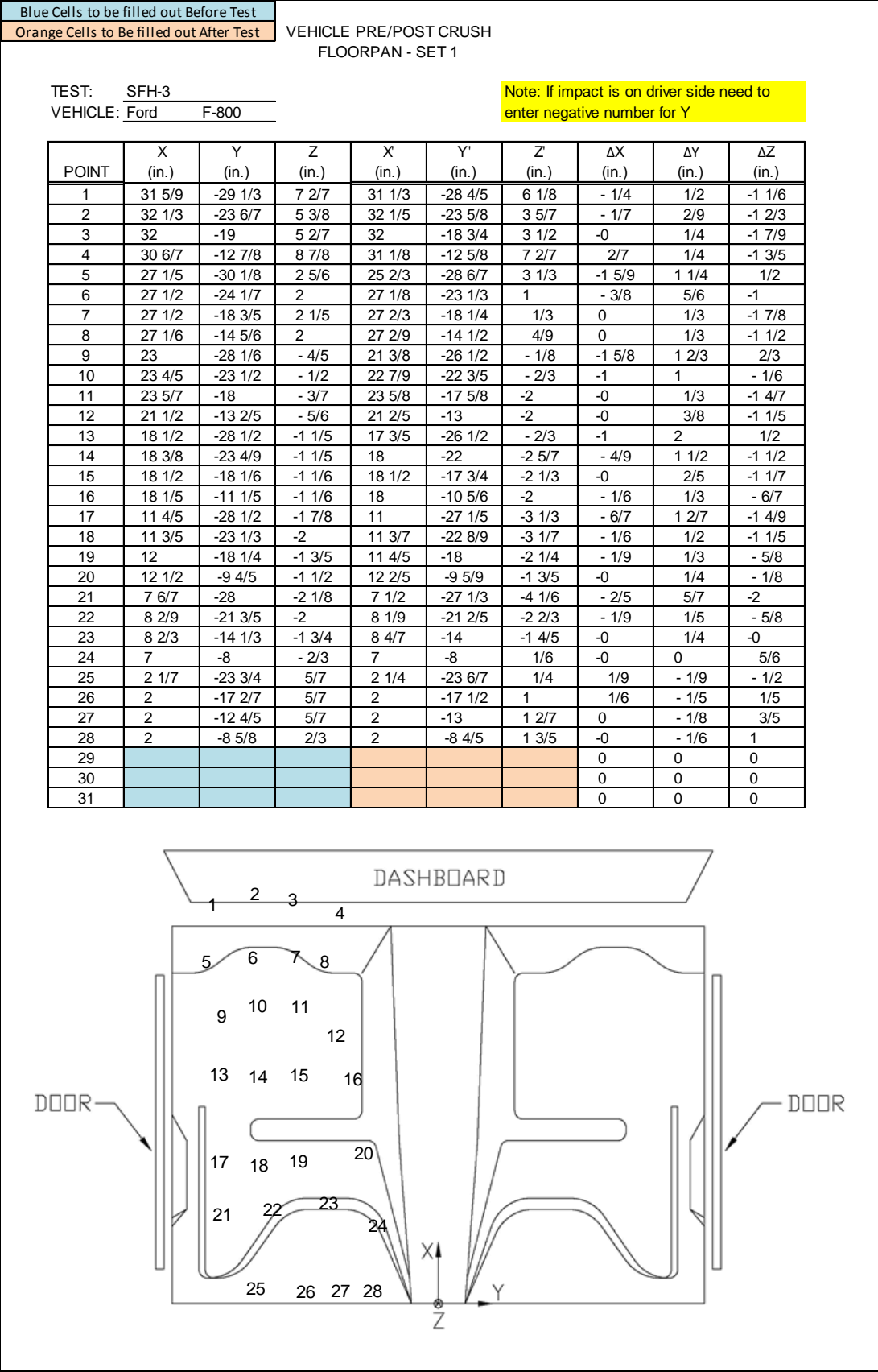

Figure C-14. Floorpan Deformation Data – Set 1, Test No. SFH-3

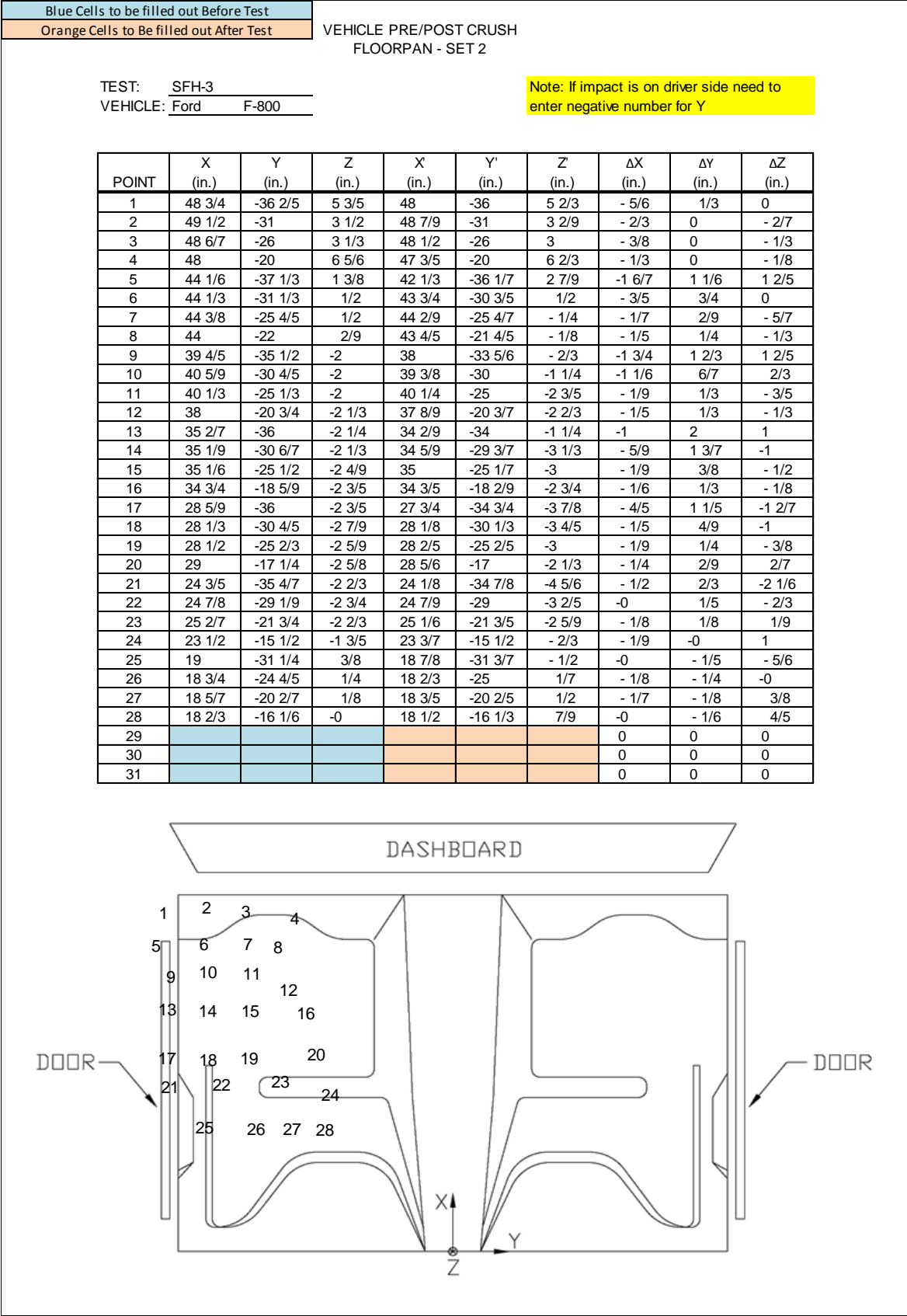

Figure C-15. Floorpan Deformation Data – Set 2, Test No. SFH-3

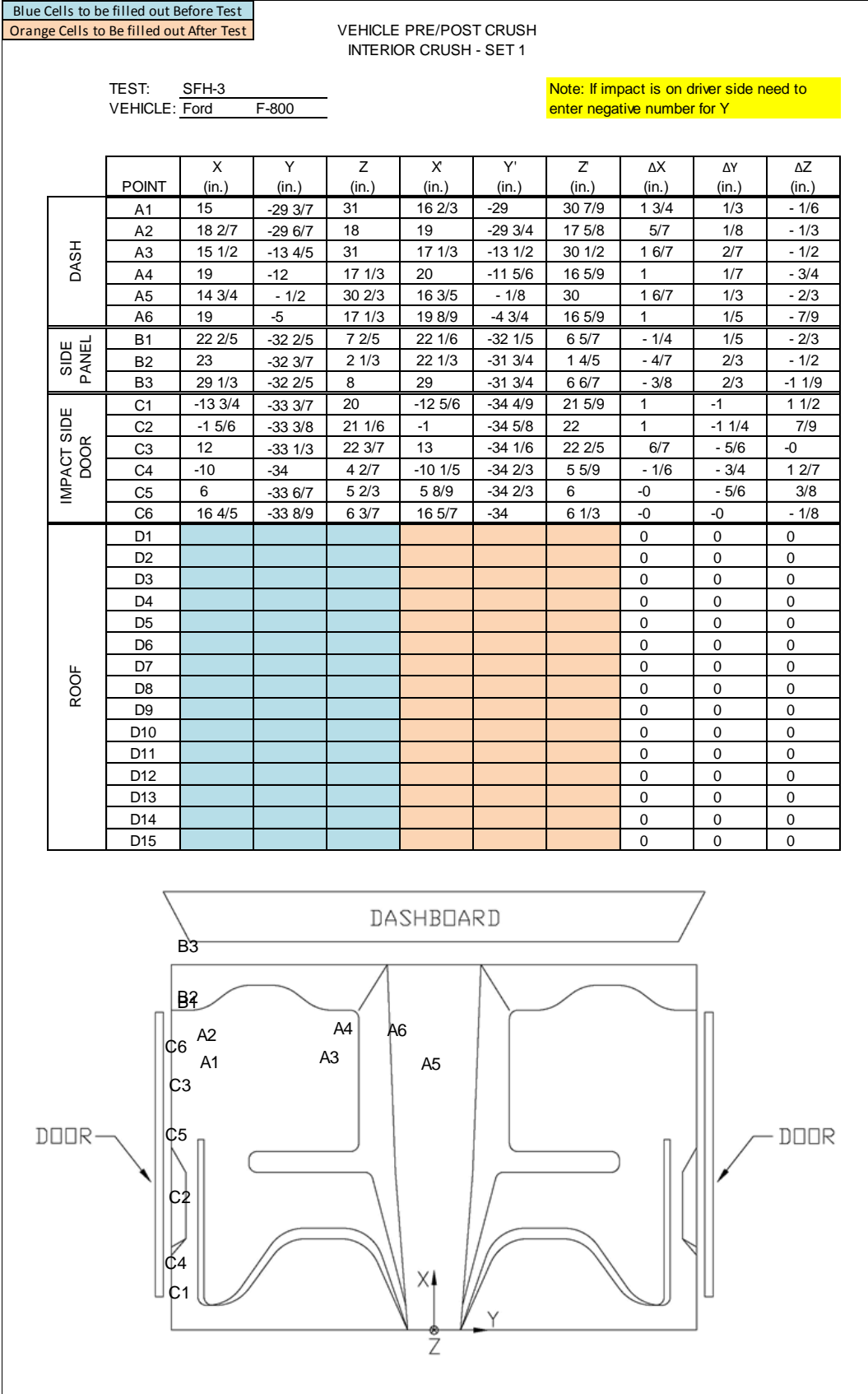

Figure C-16. Occupant Compartment Deformation Data – Set 1, Test No. SFH-3

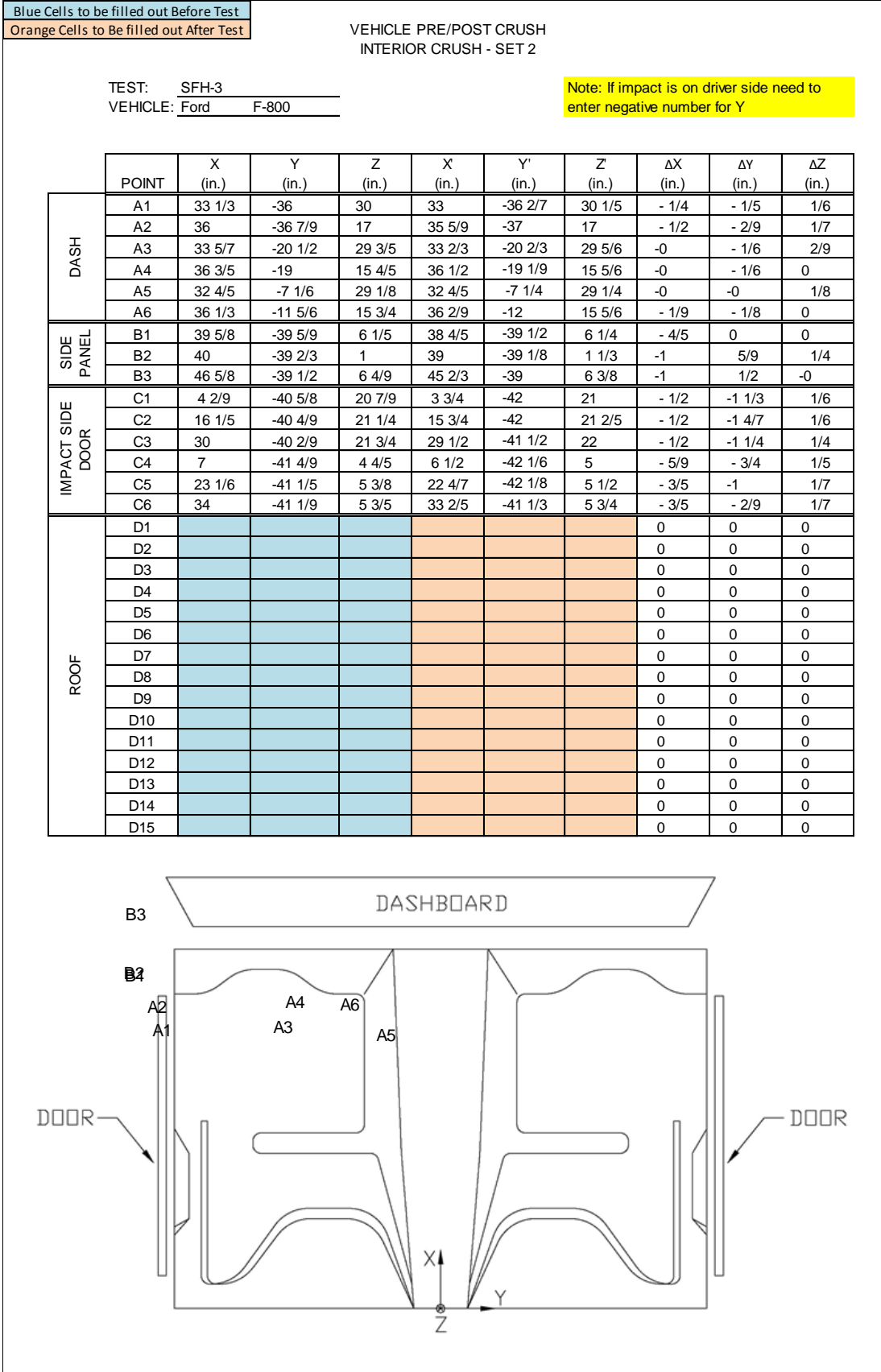

Figure C-17. Occupant Compartment Deformation Data – Set 2, Test No. SFH-3

Appendix D. Accelerometer and Rate Transducer Data Plots, Test No. SFH-1

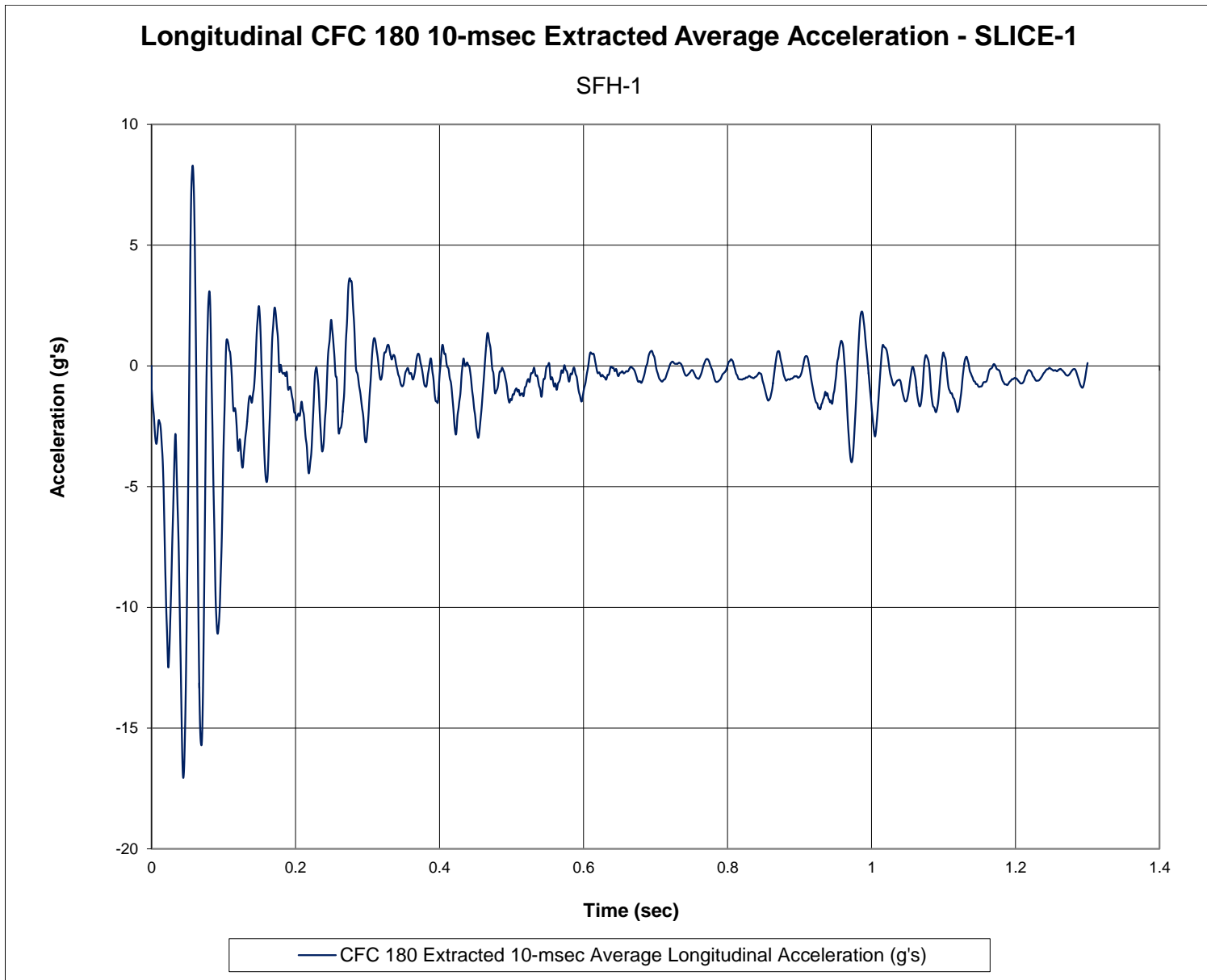

Figure D-1. 10-ms Average Longitudinal Deceleration (SLICE-1), Test No. SFH-1

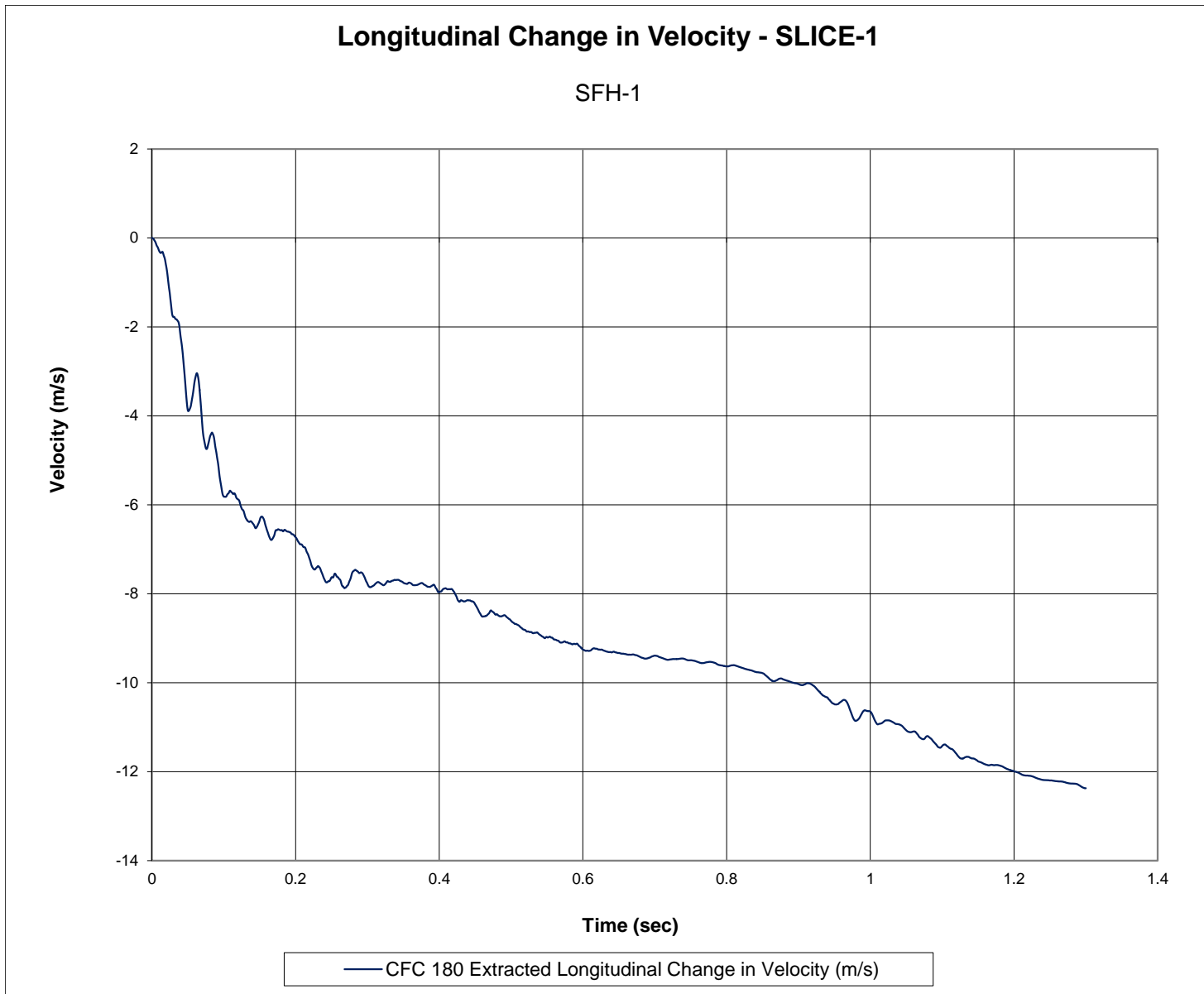

Figure D-2. Longitudinal Occupant Impact Velocity (SLICE-1), Test No. SFH-1

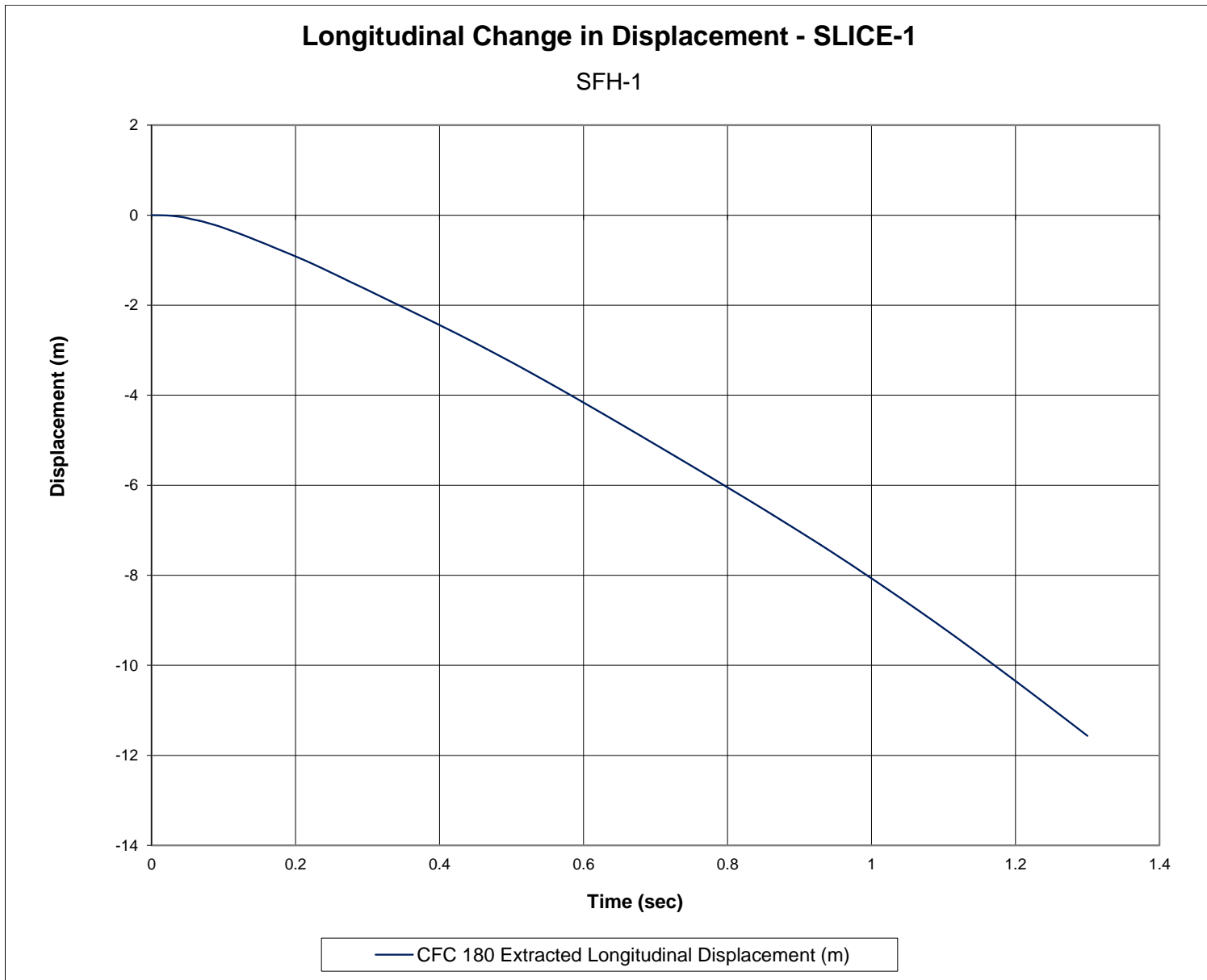

Figure D-3. Longitudinal Occupant Displacement (SLICE-1), Test No. SFH-1

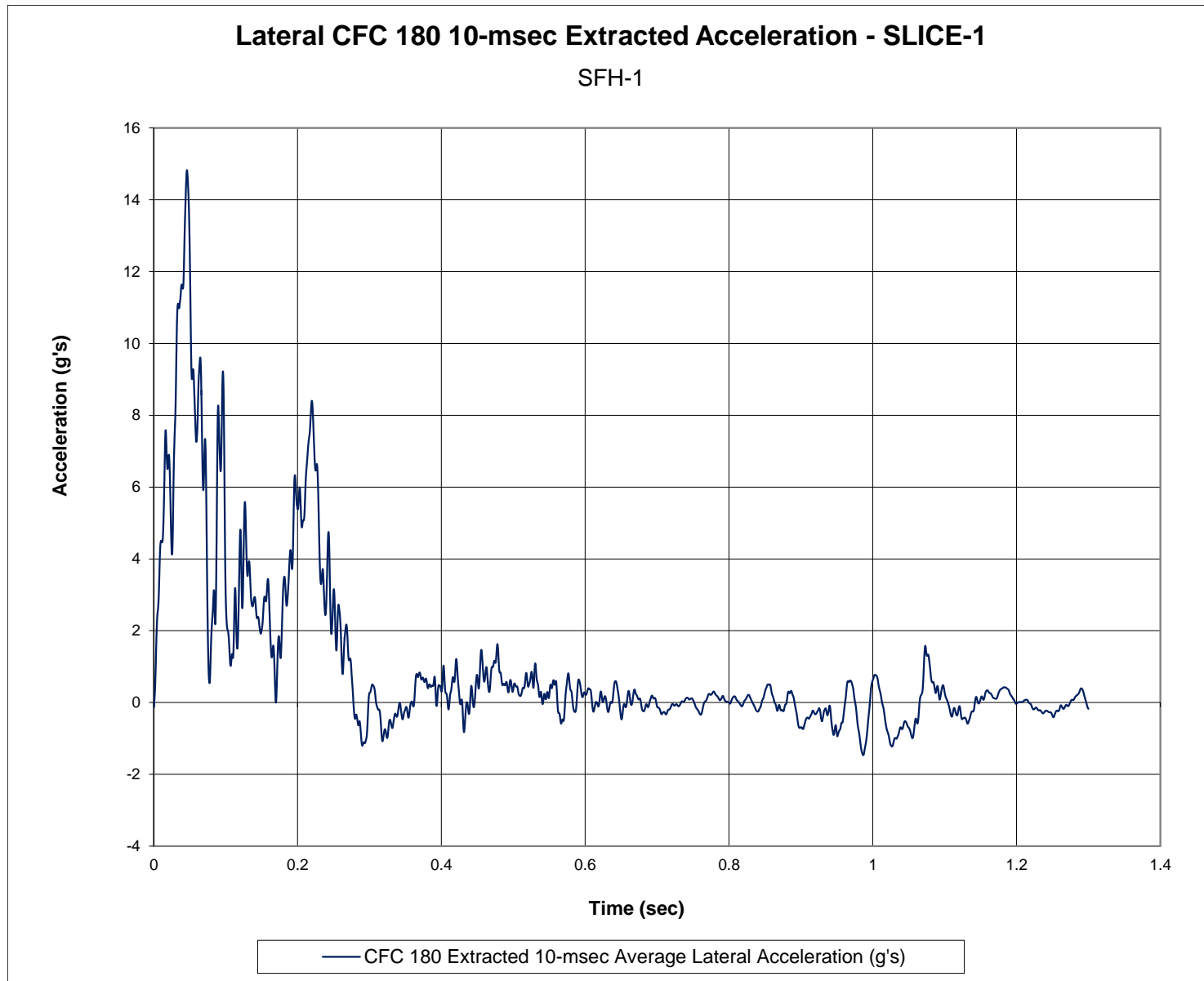

Figure D-4. 10-ms Average Lateral Deceleration (SLICE-1), Test No. SFH-1

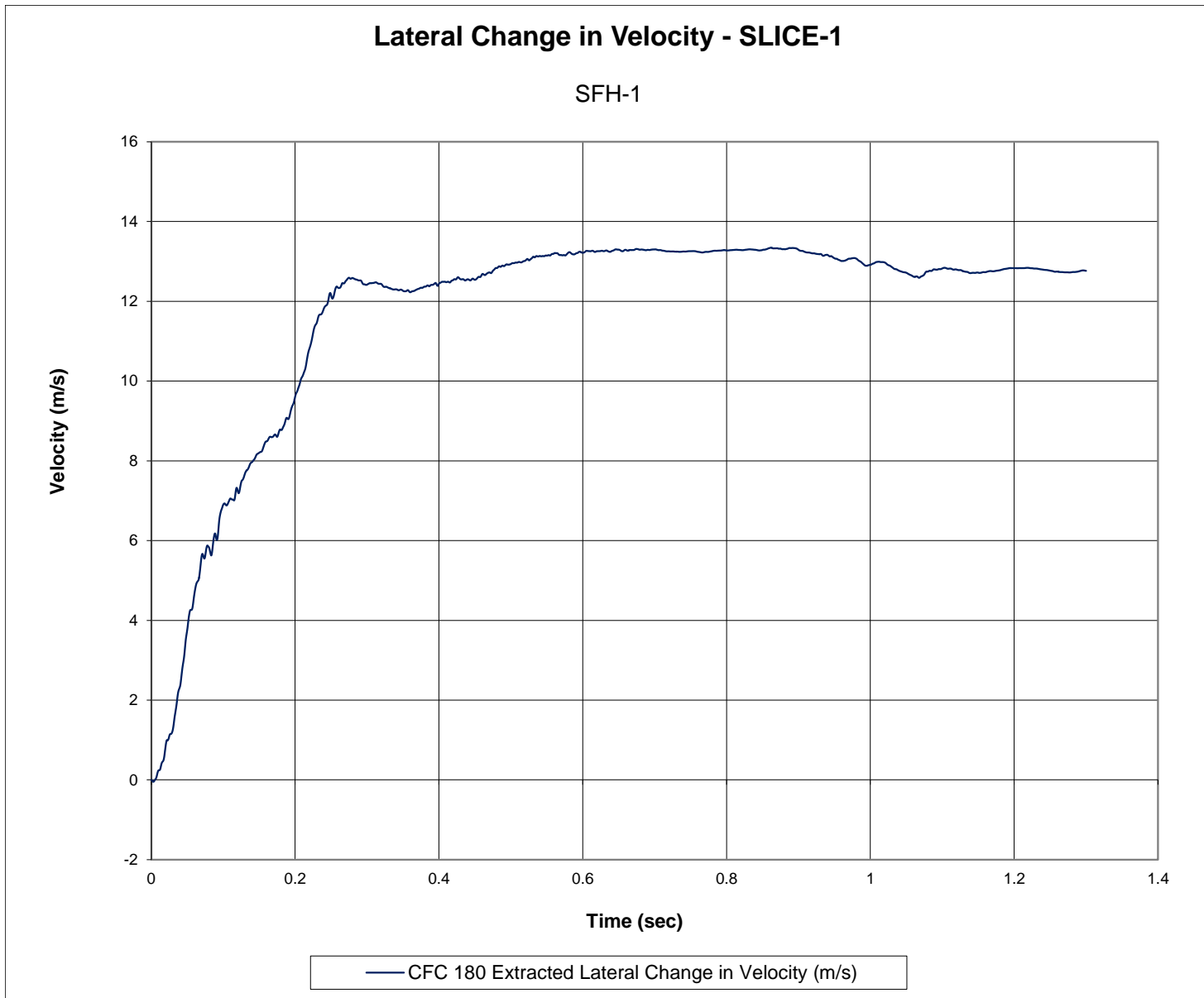

Figure D-5. Lateral Occupant Impact Velocity (SLICE-1), Test No. SFH-1

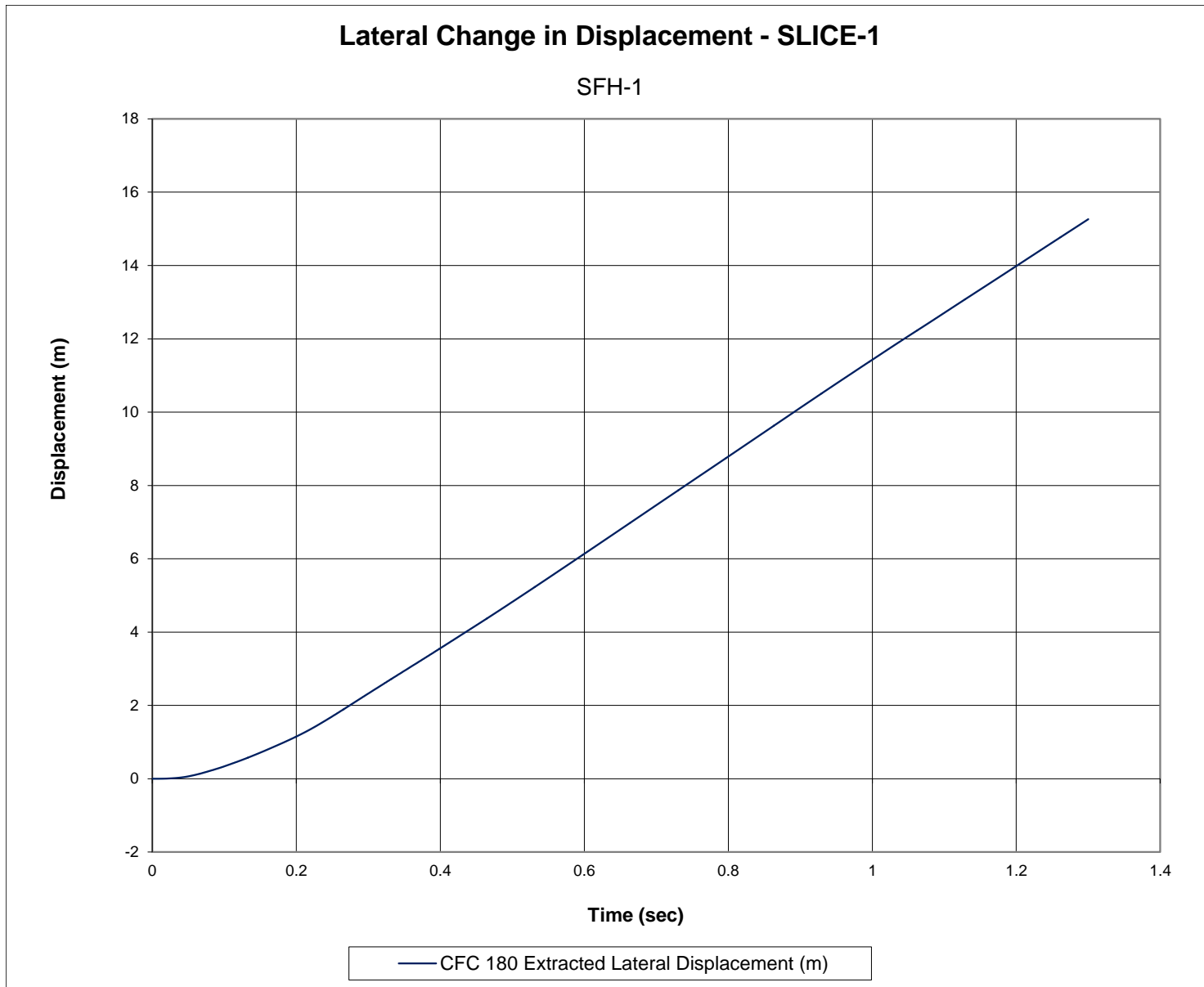

Figure D-6. Lateral Occupant Displacement (SLICE-1), Test No. SFH-1

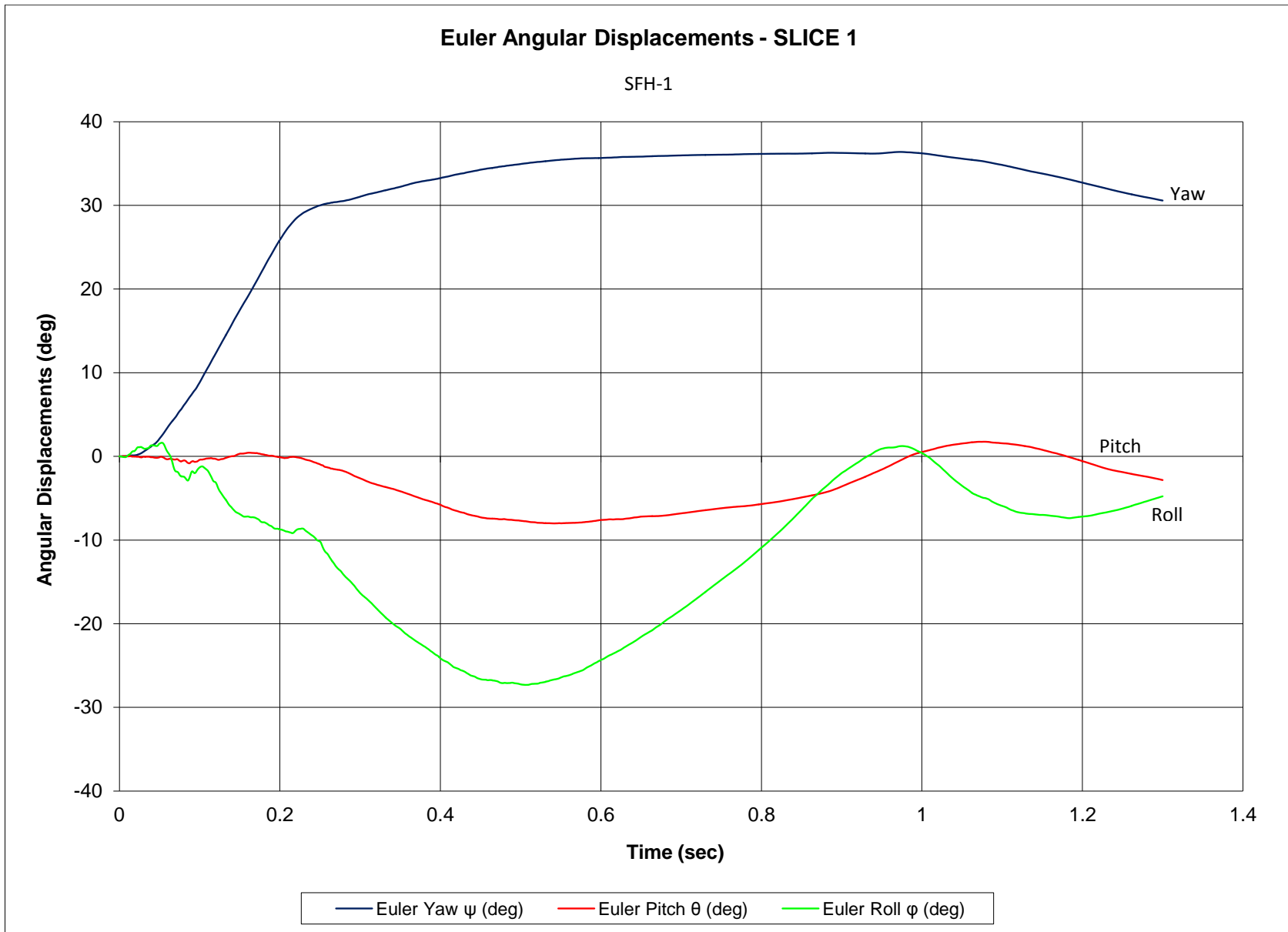

Figure D-7. Vehicle Angular Displacements (SLICE-1), Test No. SFH-1

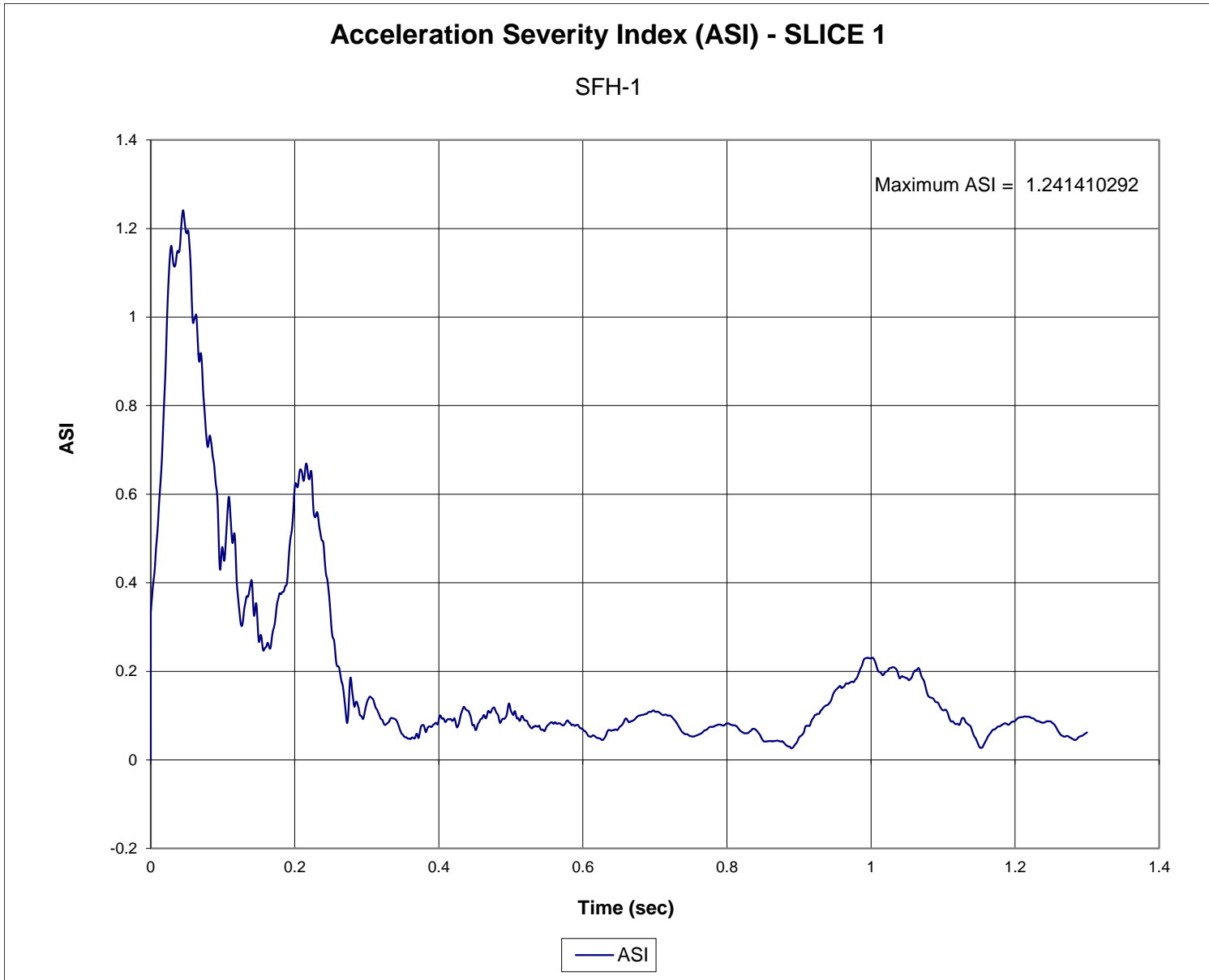

Figure D-8. Acceleration Severity Index (SLICE-1), Test No. SFH-1

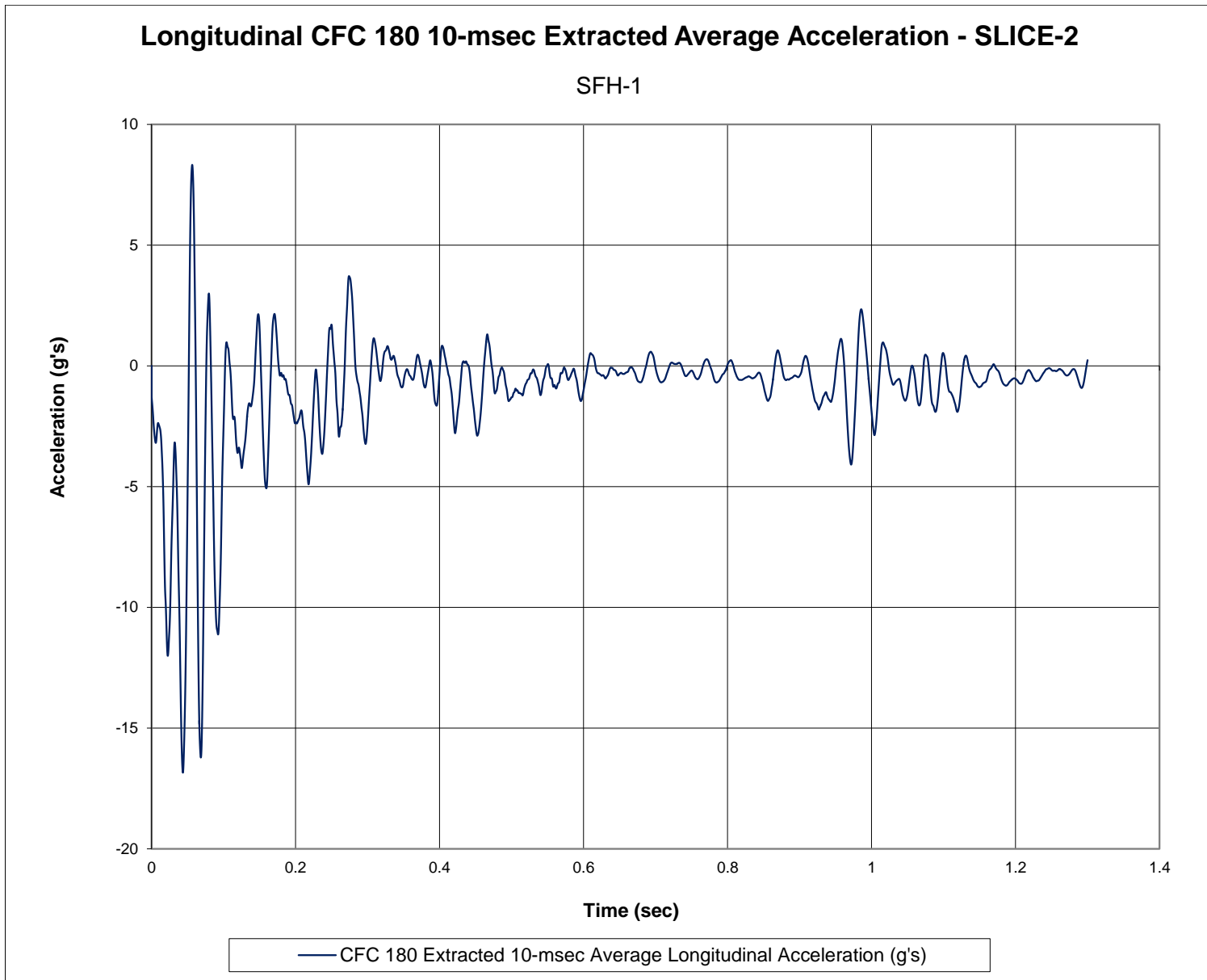

Figure D-9. 10-ms Average Longitudinal Deceleration (SLICE-2), Test No. SFH-1

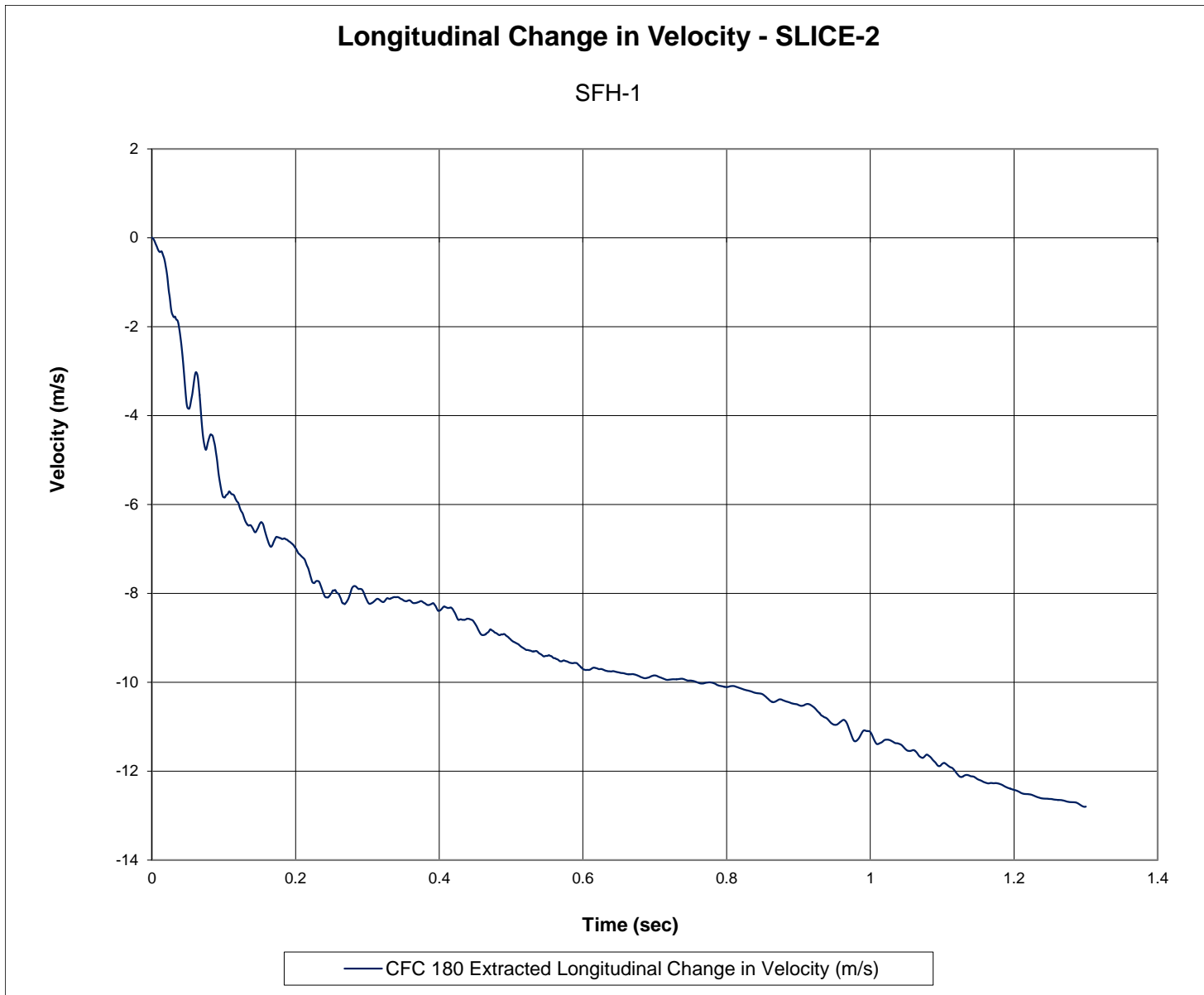

Figure D-10. Longitudinal Occupant Impact Velocity (SLICE-2), Test No. SFH-1

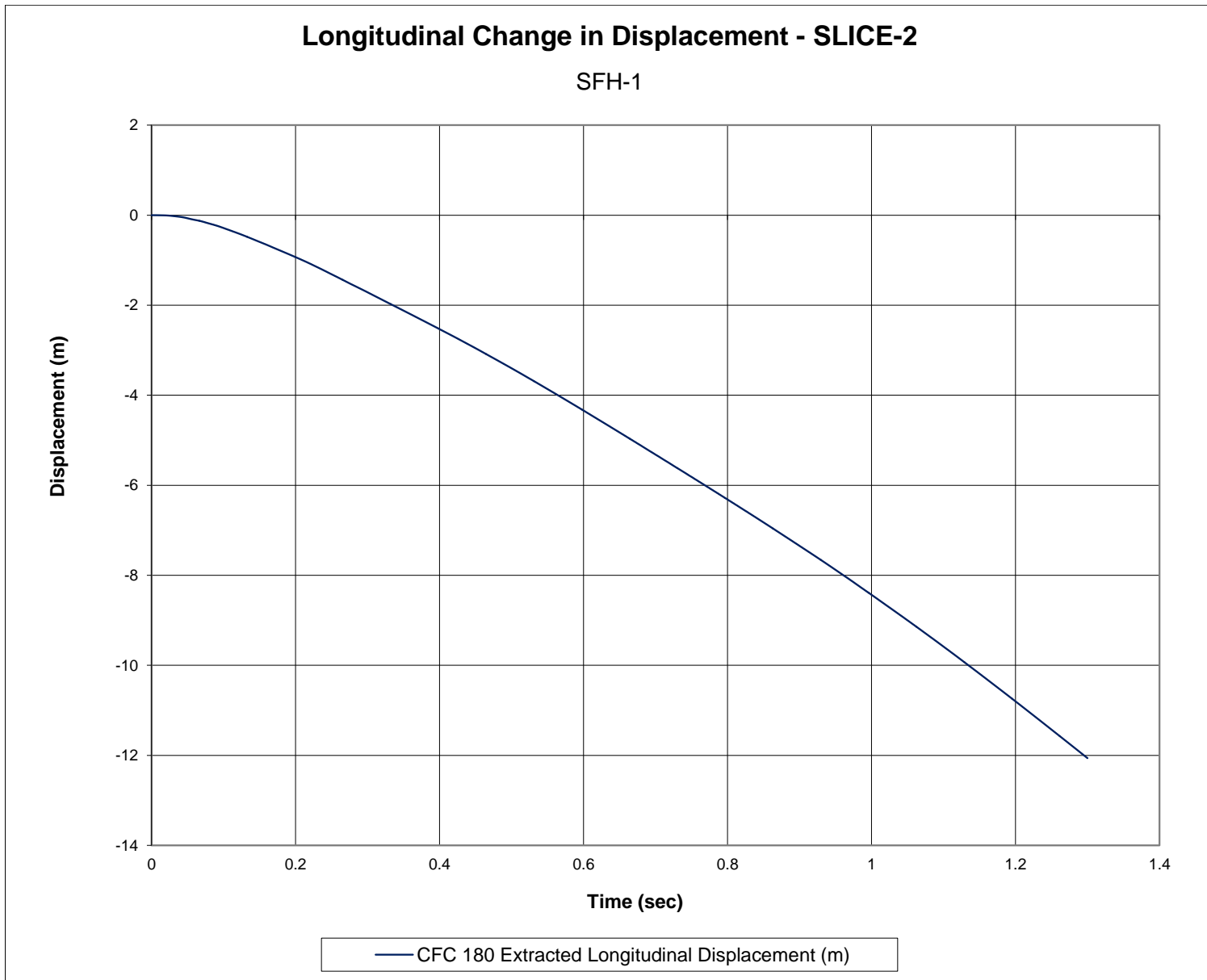

Figure D-11. Longitudinal Occupant Displacement (SLICE-2), Test No. SFH-1

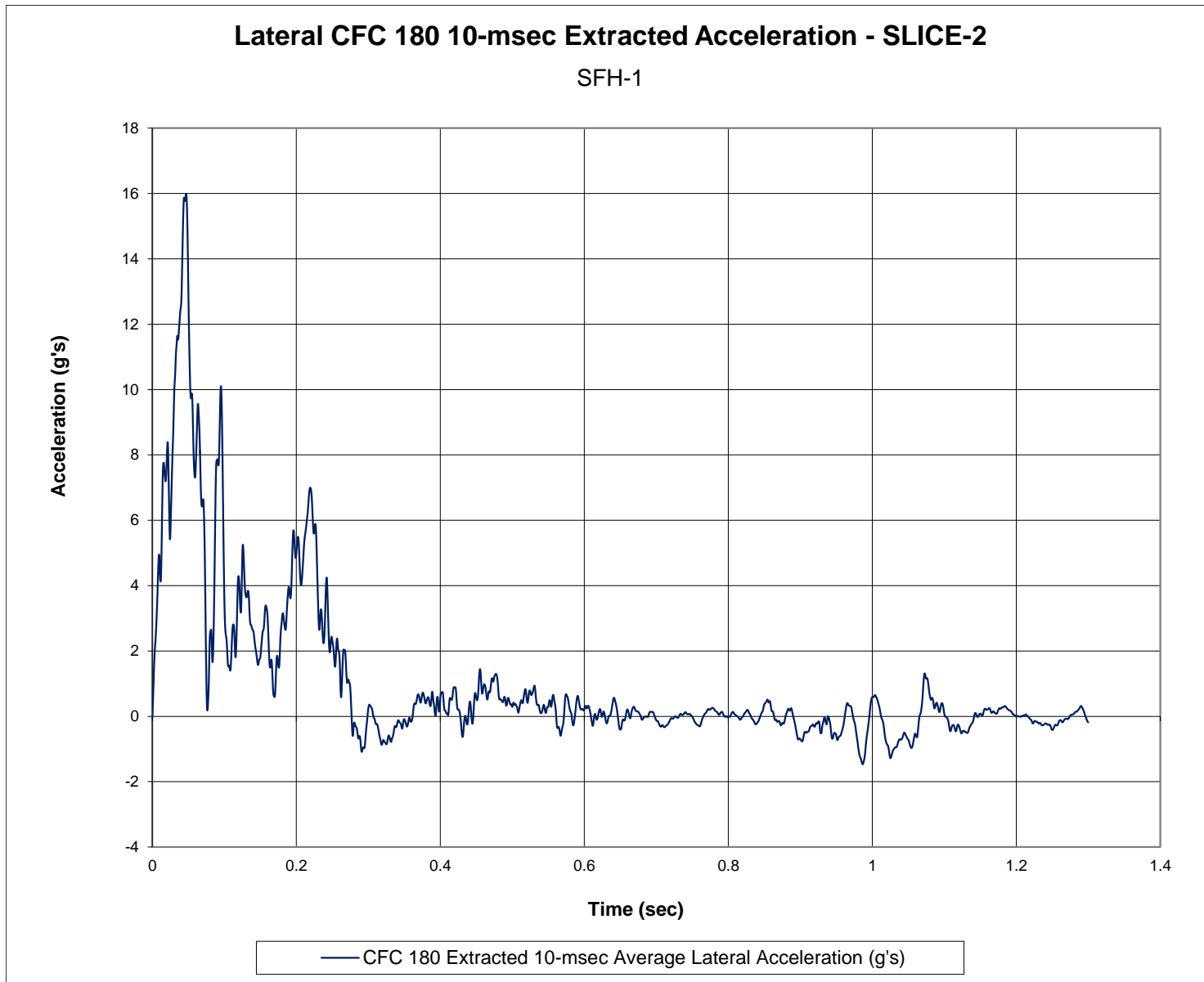

Figure D-12. 10-ms Average Lateral Deceleration (SLICE-2), Test No. SFH-1

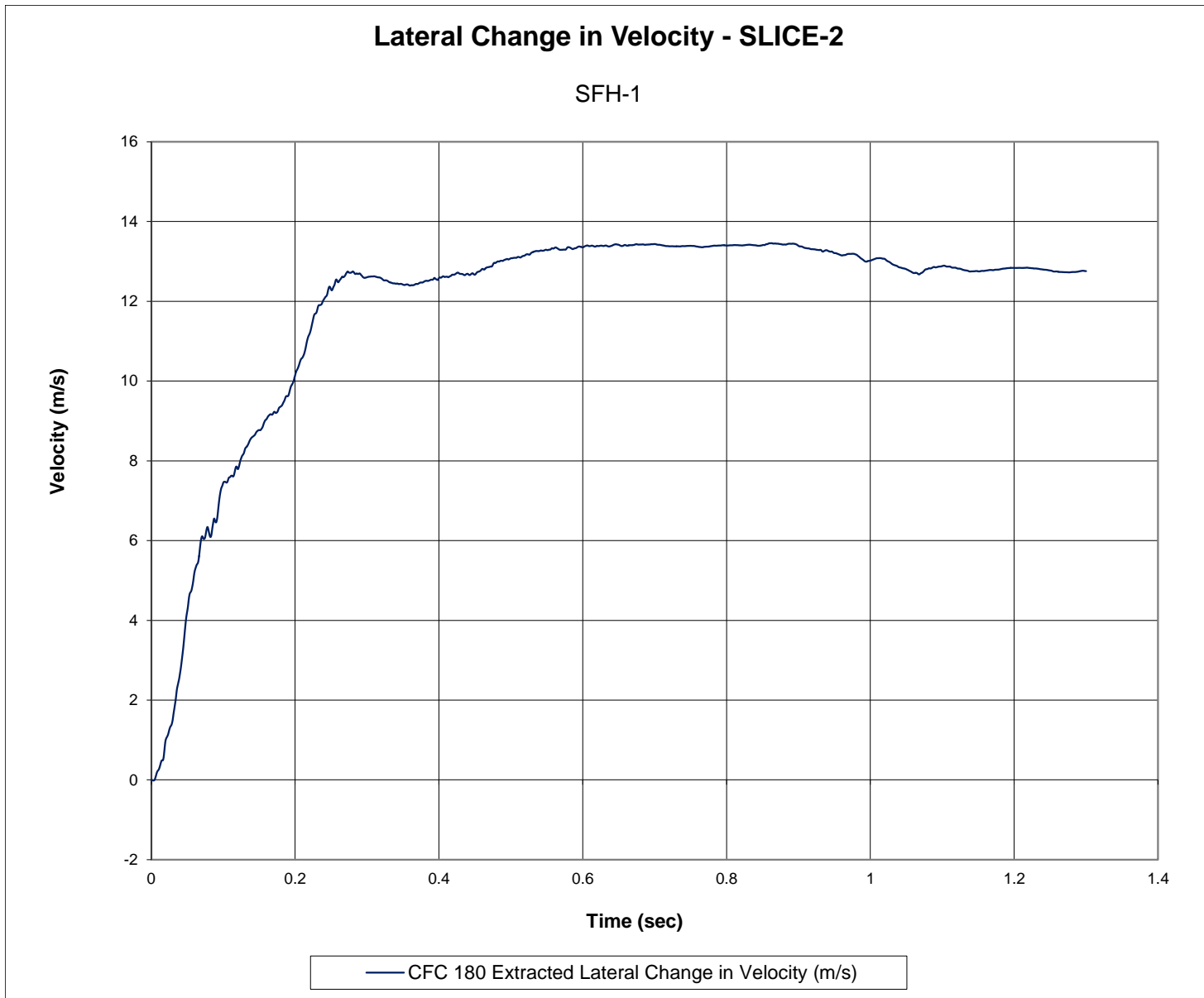

Figure D-13. Lateral Occupant Impact Velocity (SLICE-2), Test No. SFH-1

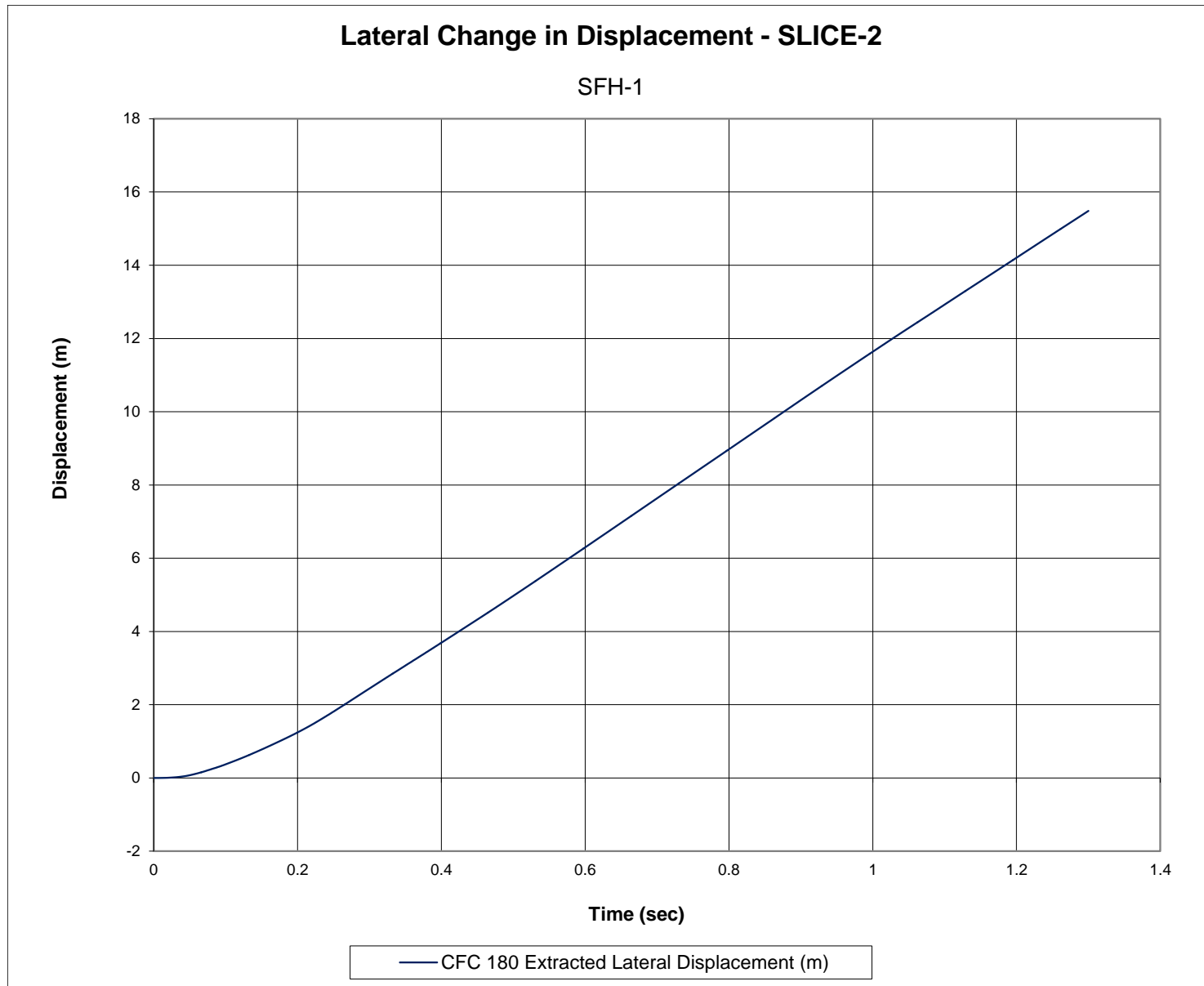

Figure D-14. Lateral Occupant Displacement (SLICE-2), Test No. SFH-1

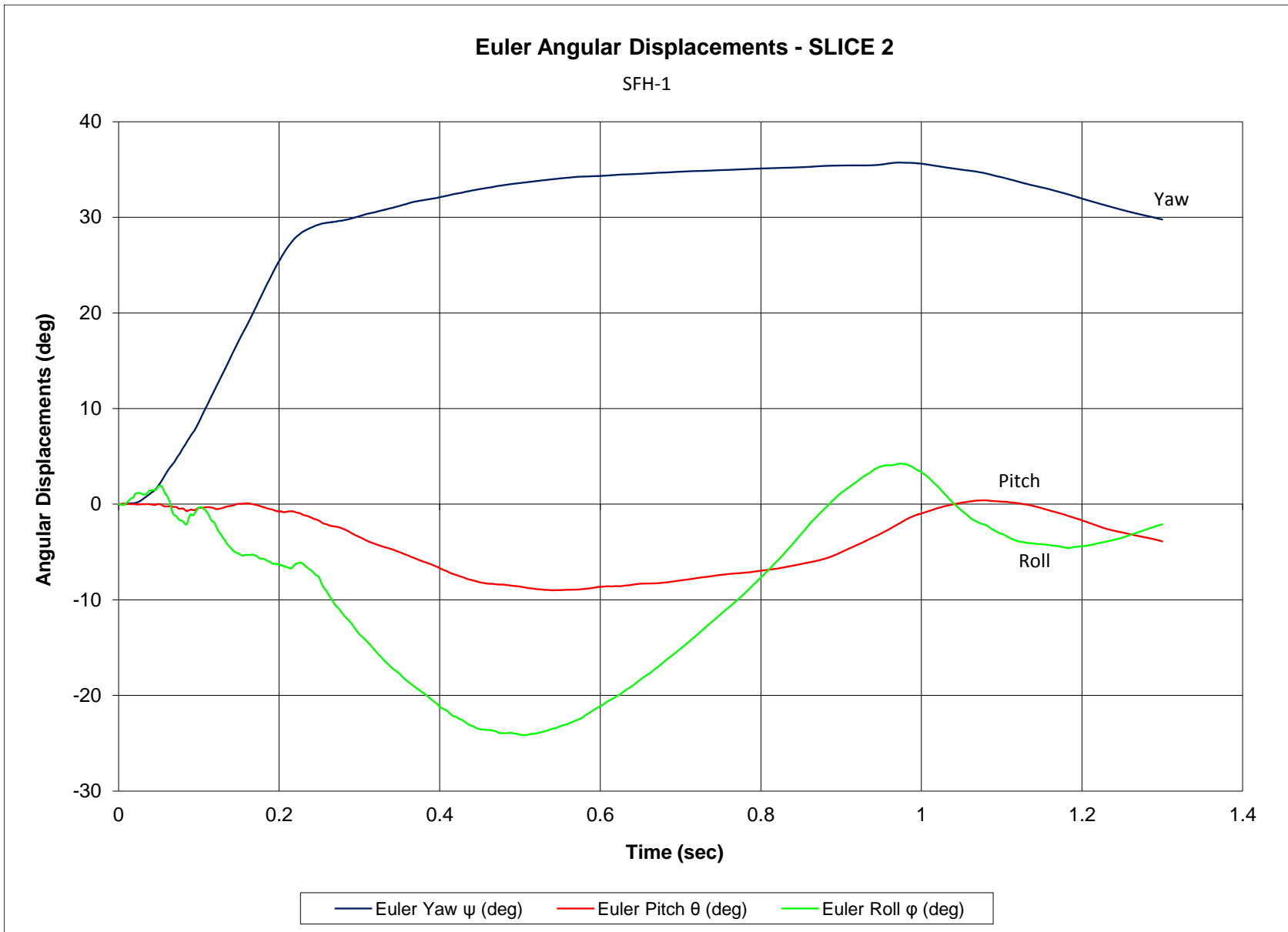

Figure D-15. Vehicle Angular Displacements (SLICE-2), Test No. SFH-1

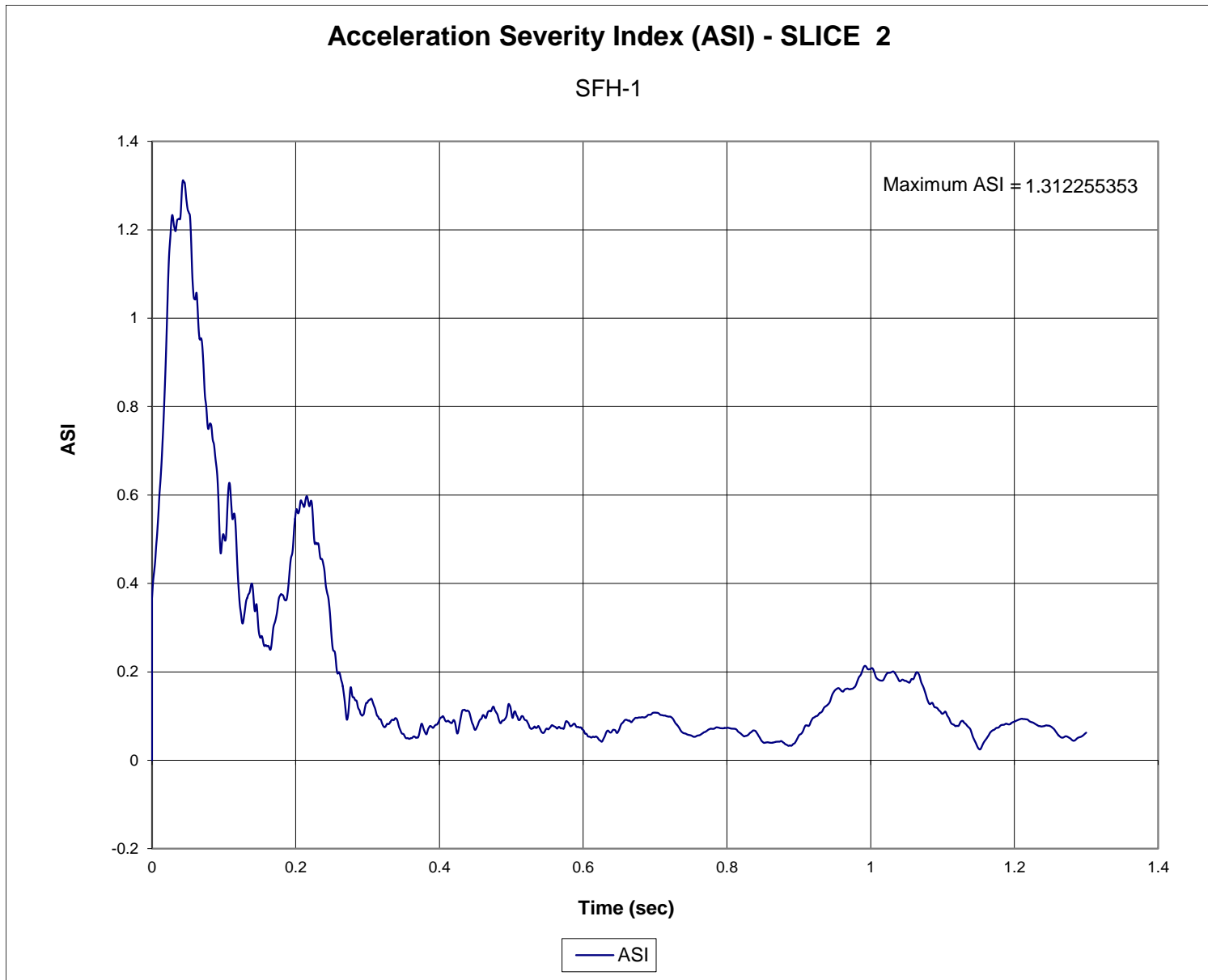

Figure D-16. Acceleration Severity Index (SLICE-2), Test No. SFH-1

Appendix E. Accelerometer and Rate Transducer Data Plots, Test No. SFH-2

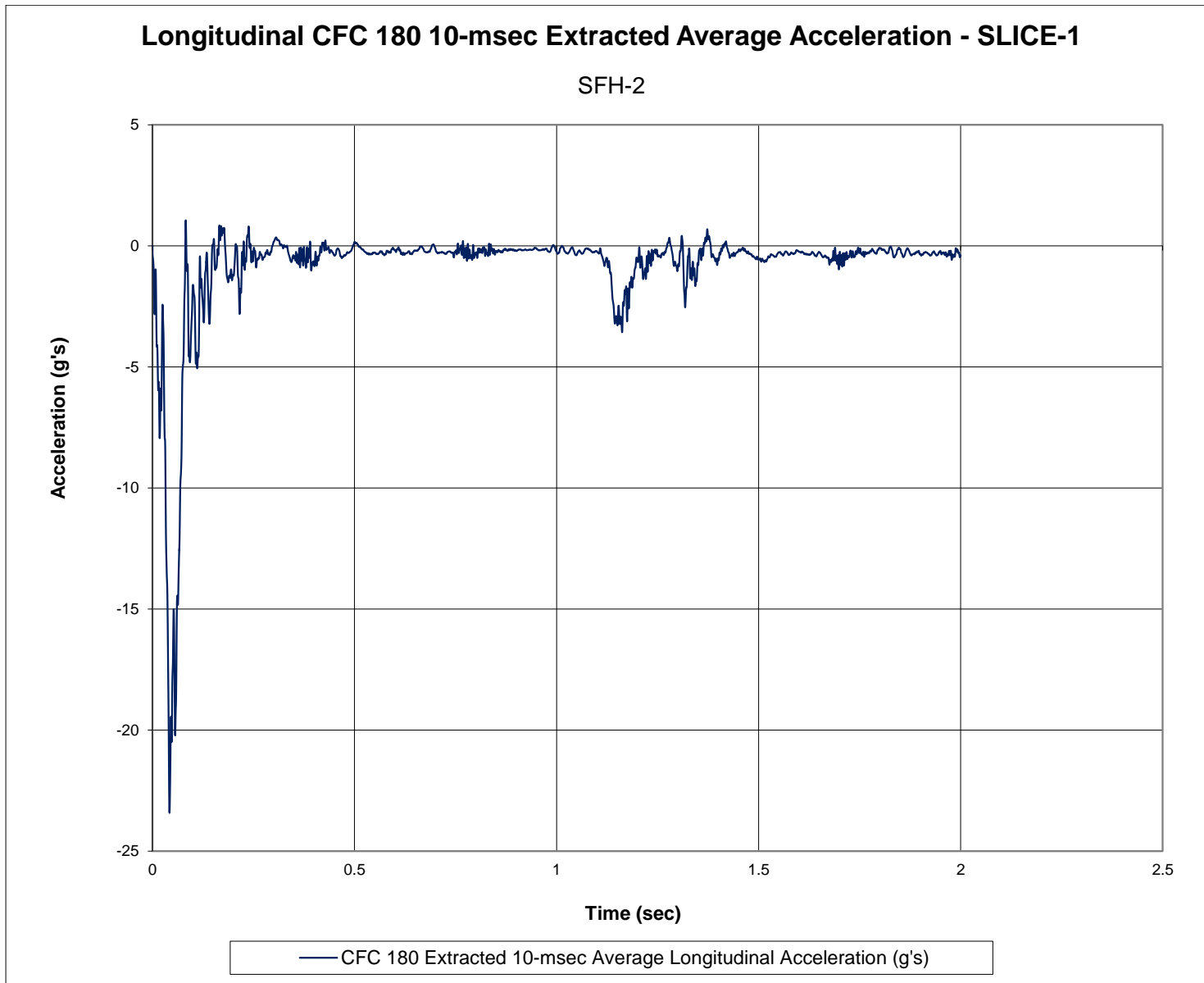

Figure E-1. 10-ms Average Longitudinal Deceleration (SLICE-1), Test No. SFH-2

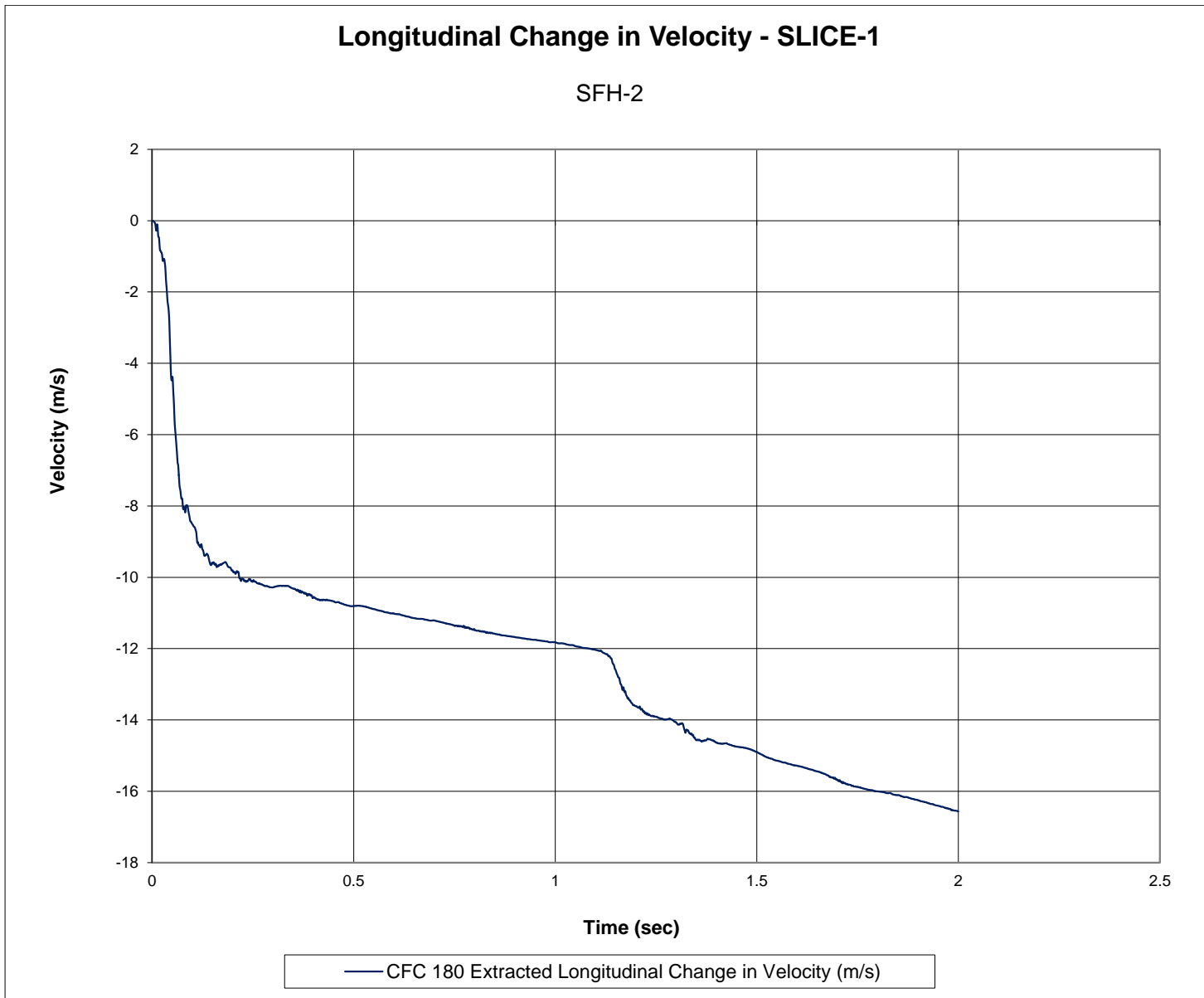

Figure E-2. Longitudinal Occupant Impact Velocity (SLICE-1), Test No. SFH-2

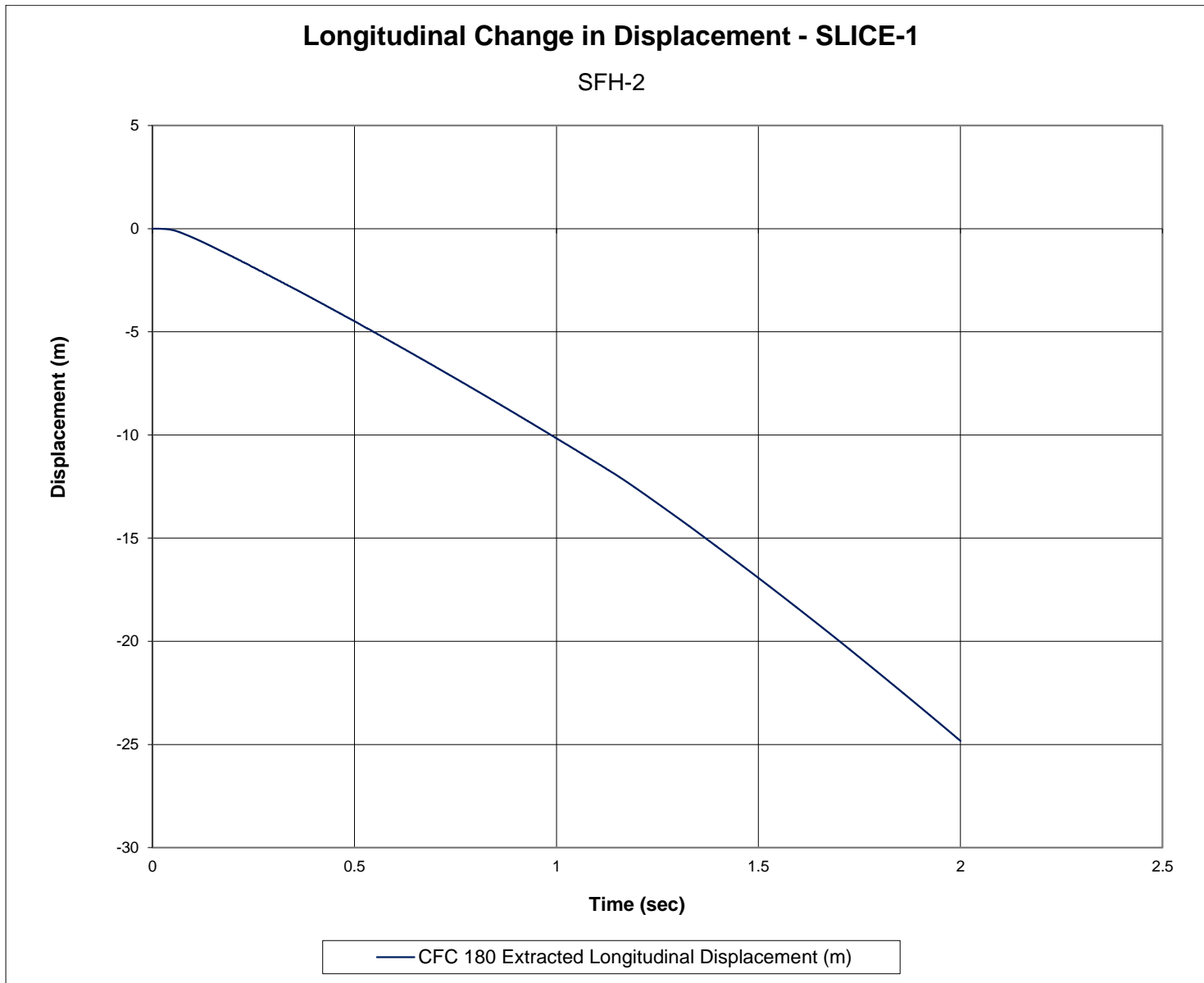

Figure E-3. Longitudinal Occupant Displacement (SLICE-1), Test No. SFH-2

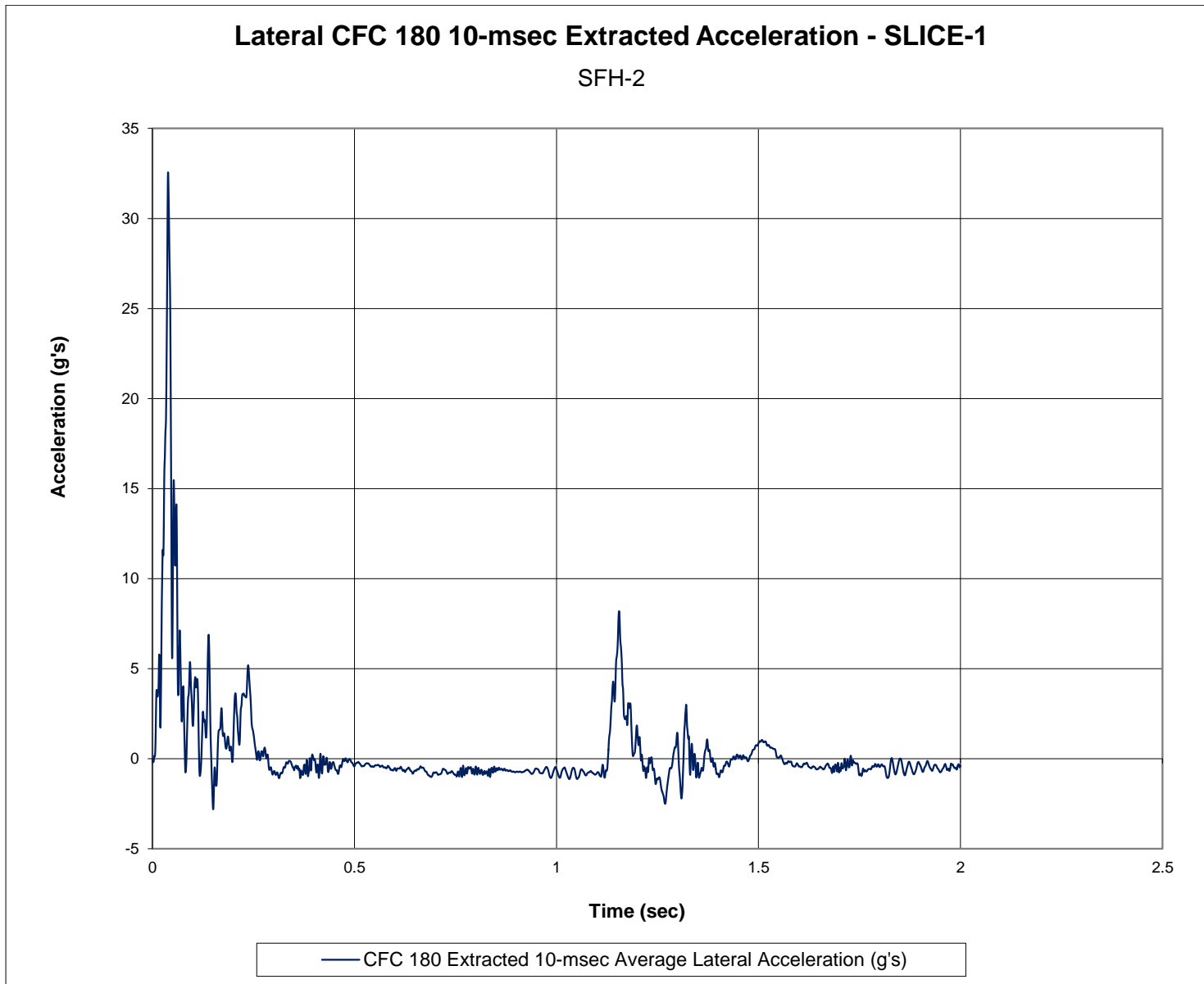

Figure E-4. 10-ms Average Lateral Deceleration (SLICE-1), Test No. SFH-2

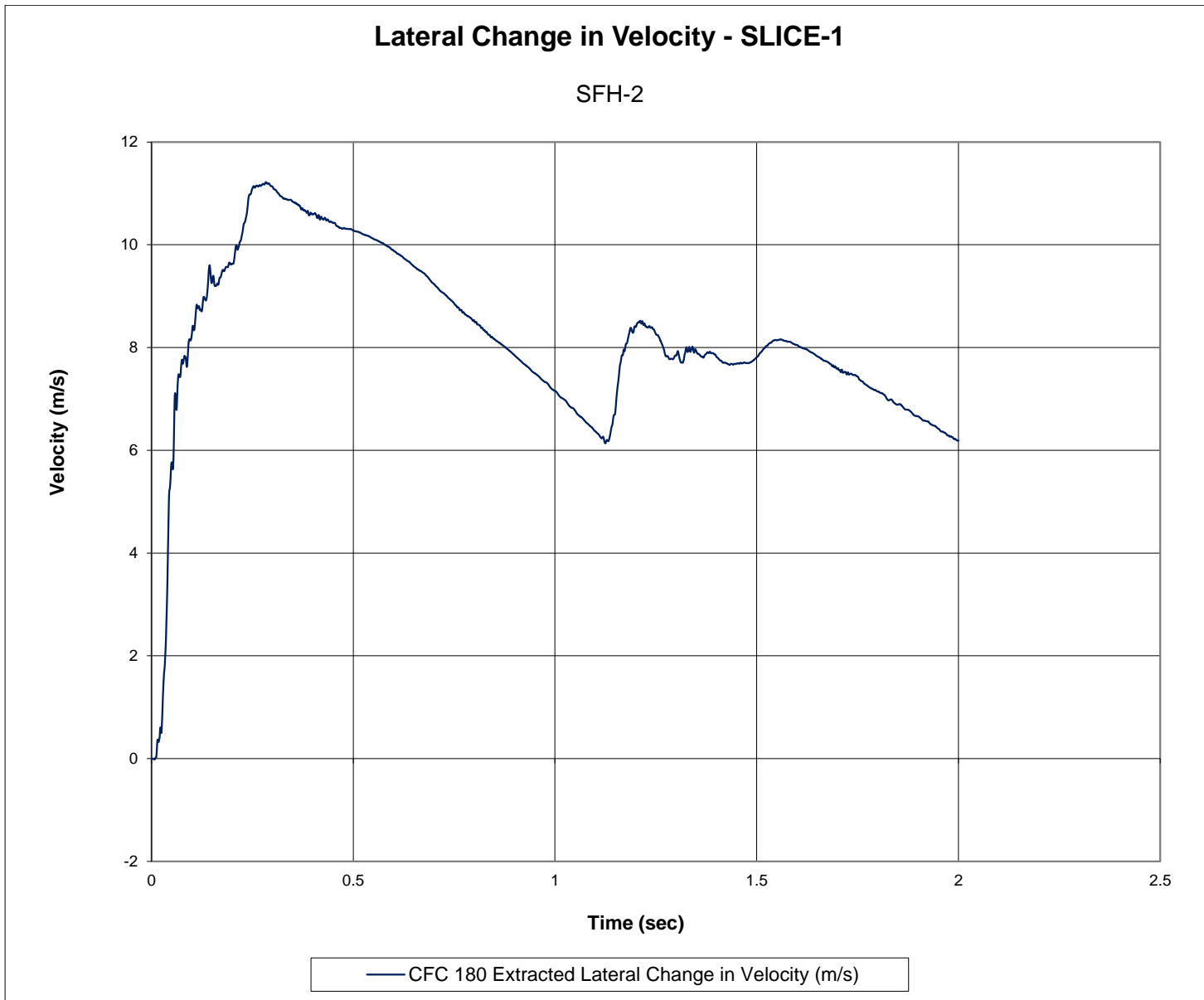

Figure E-5. Lateral Occupant Impact Velocity (SLICE-1), Test No. SFH-2

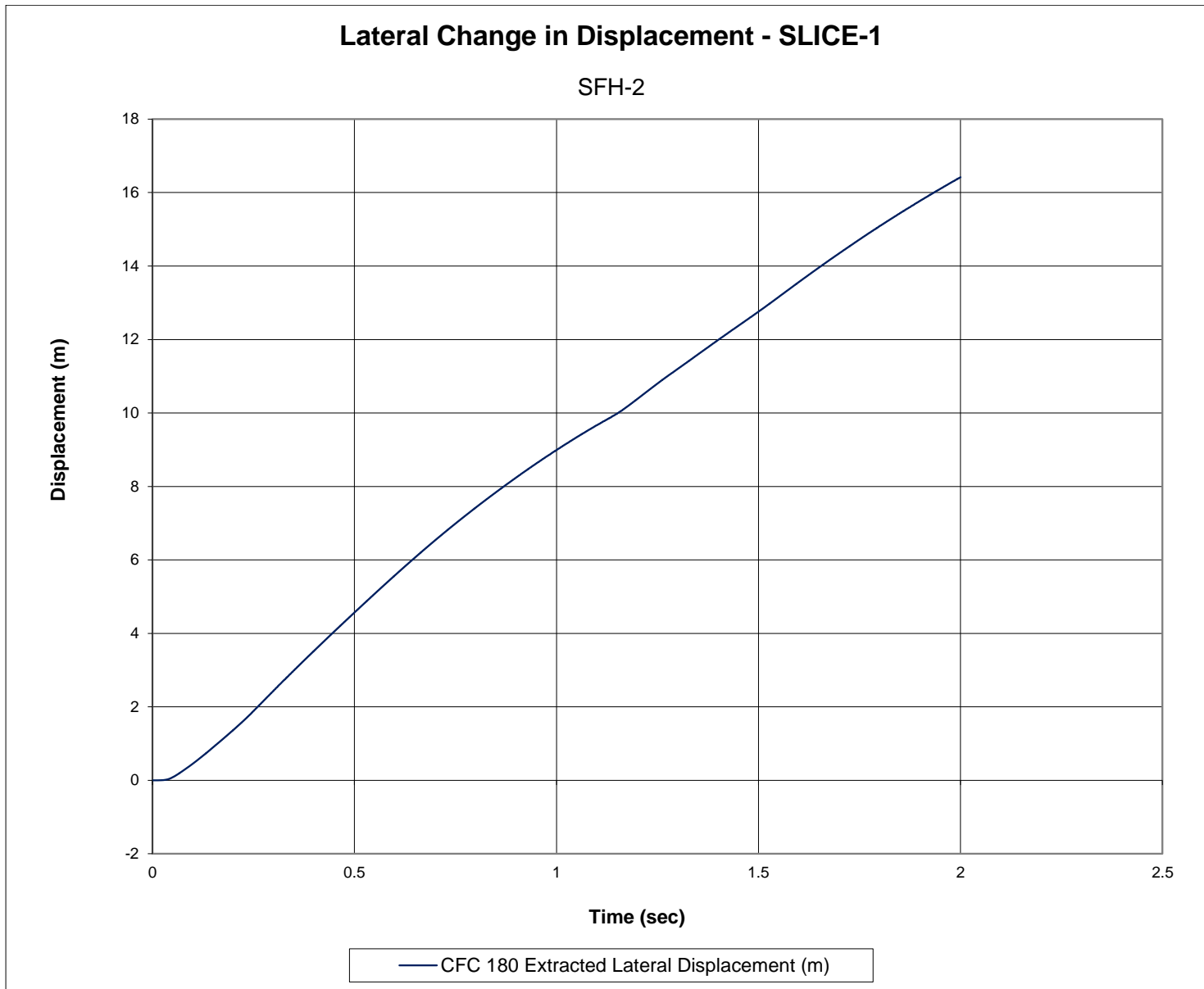

Figure E-6. Lateral Occupant Displacement (SLICE-1), Test No. SFH-2



Figure E-7. Vehicle Angular Displacements (SLICE-1), Test No. SFH-2

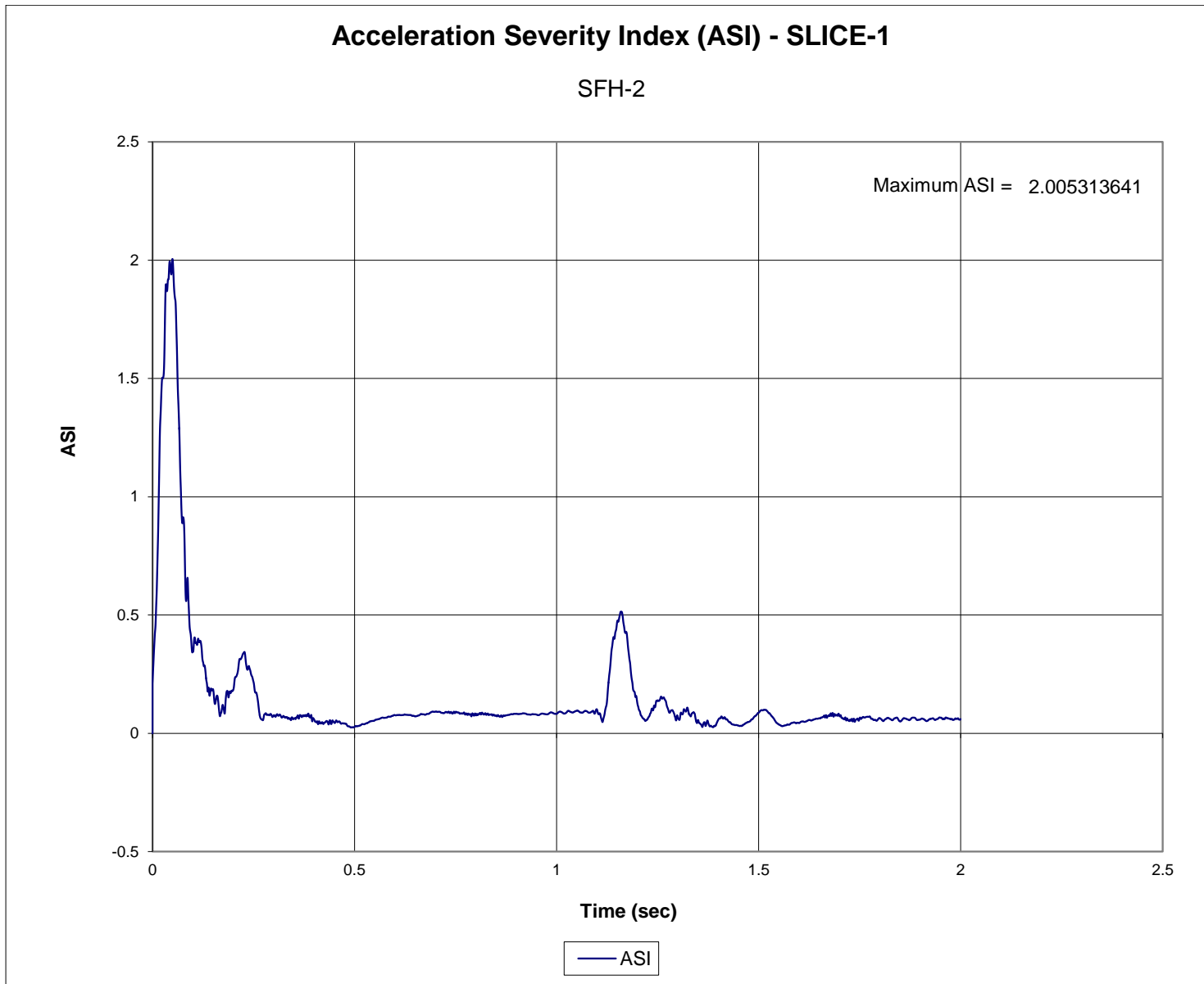

Figure E-8. Acceleration Severity Index (SLICE-1), Test No. SFH-2

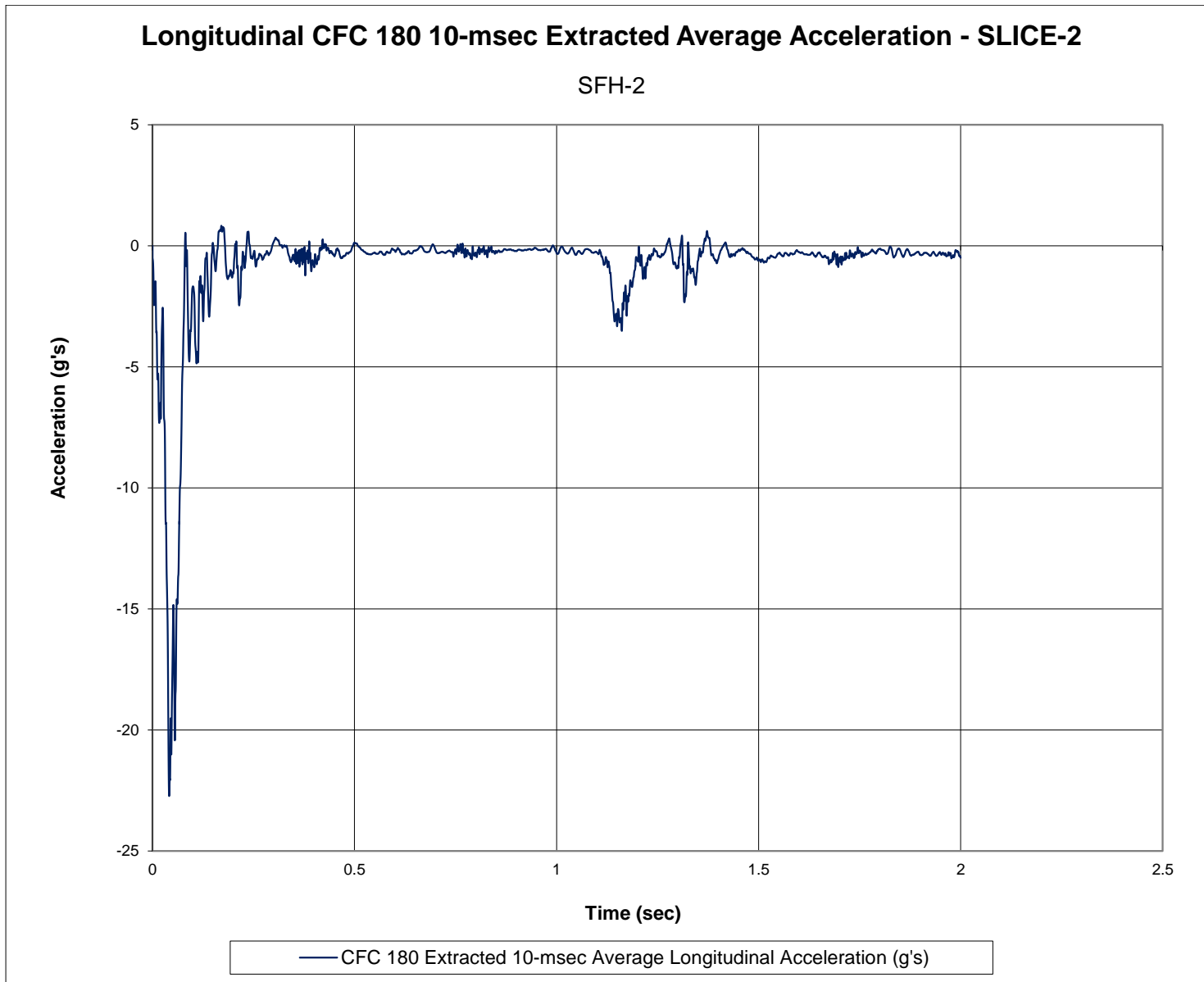

Figure E-9. 10-ms Average Longitudinal Deceleration (SLICE-2), Test No. SFH-2

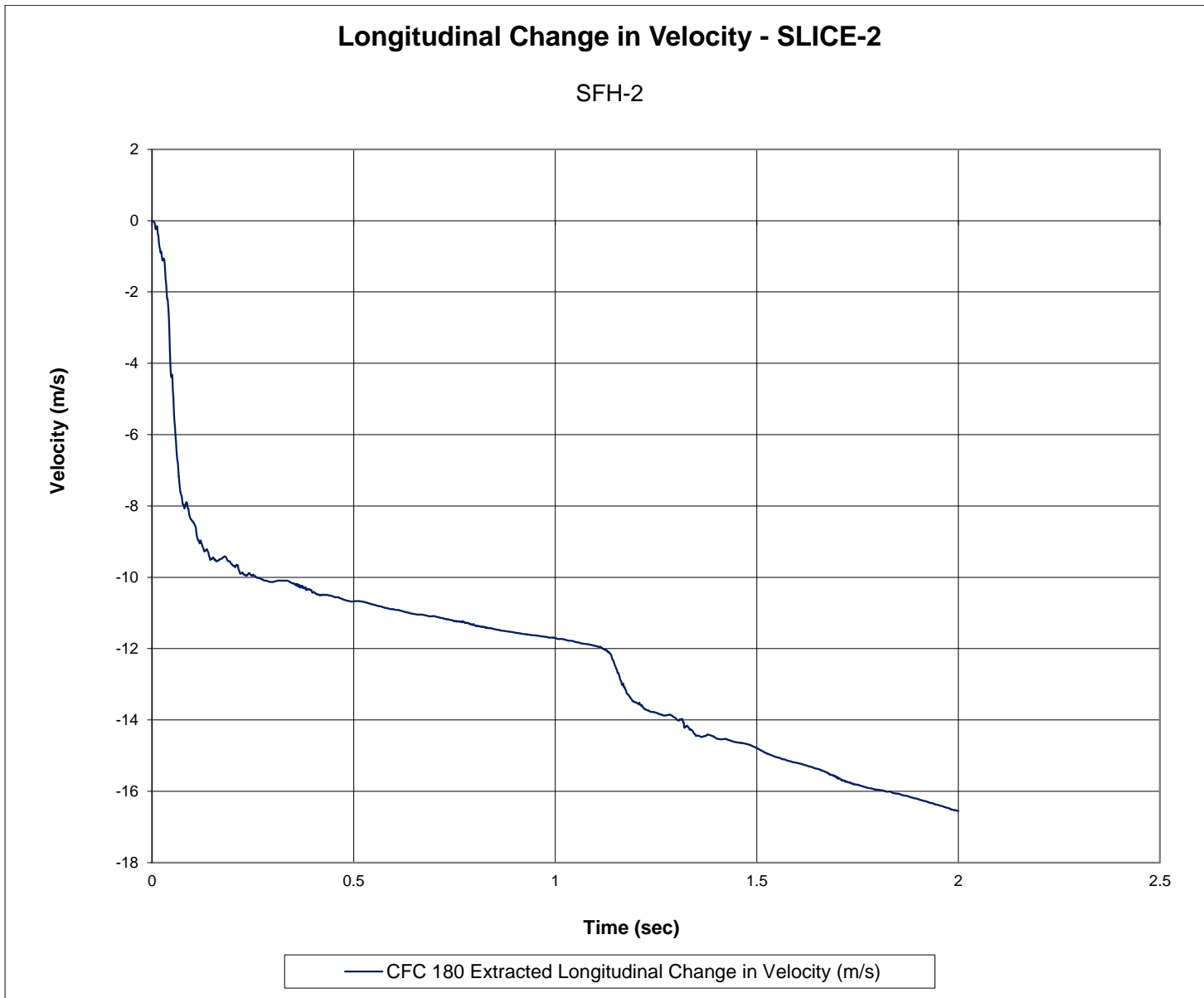

Figure E-10. Longitudinal Occupant Impact Velocity (SLICE-2), Test No. SFH-2

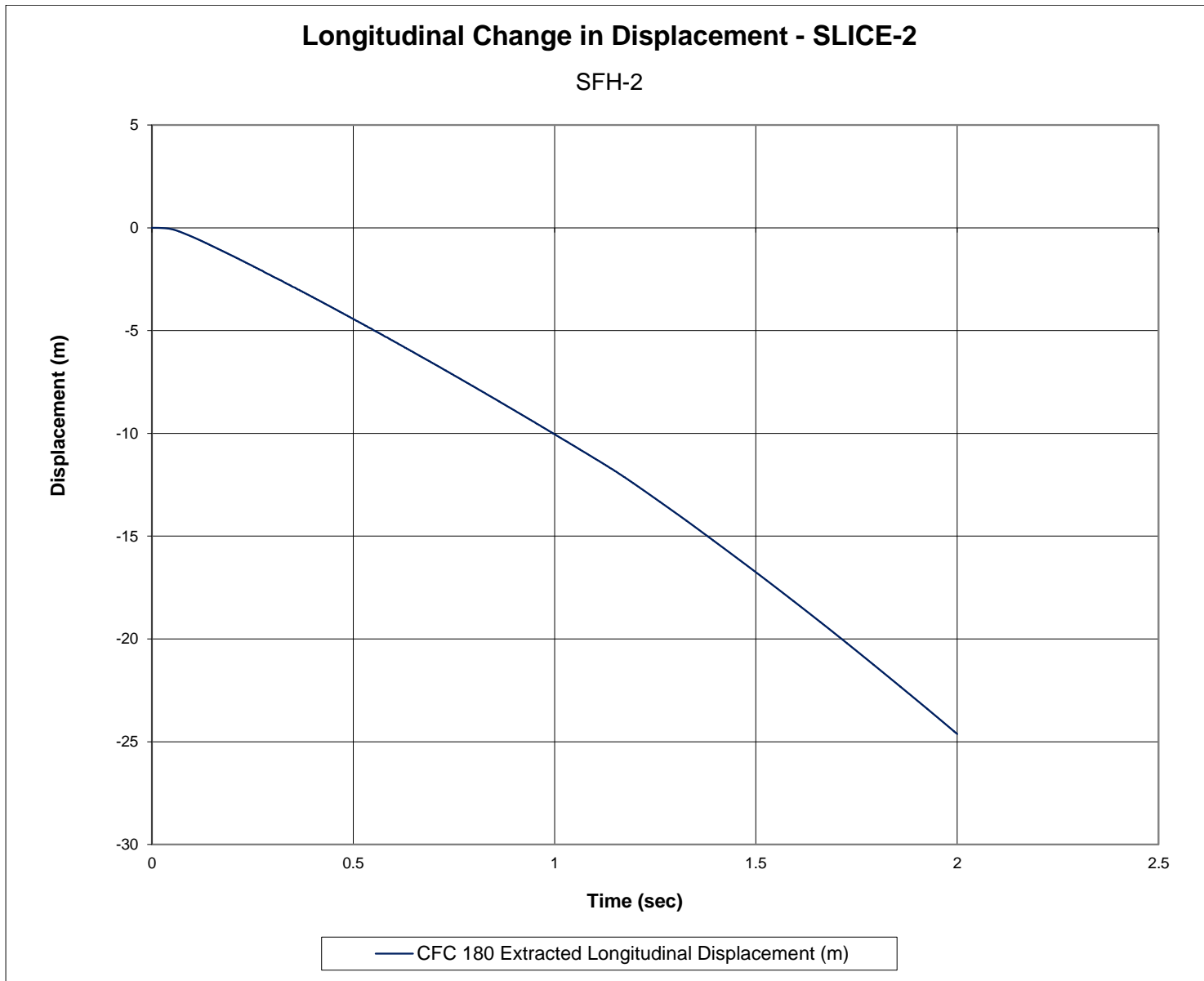

Figure E-11. Longitudinal Occupant Displacement (SLICE-2), Test No. SFH-2

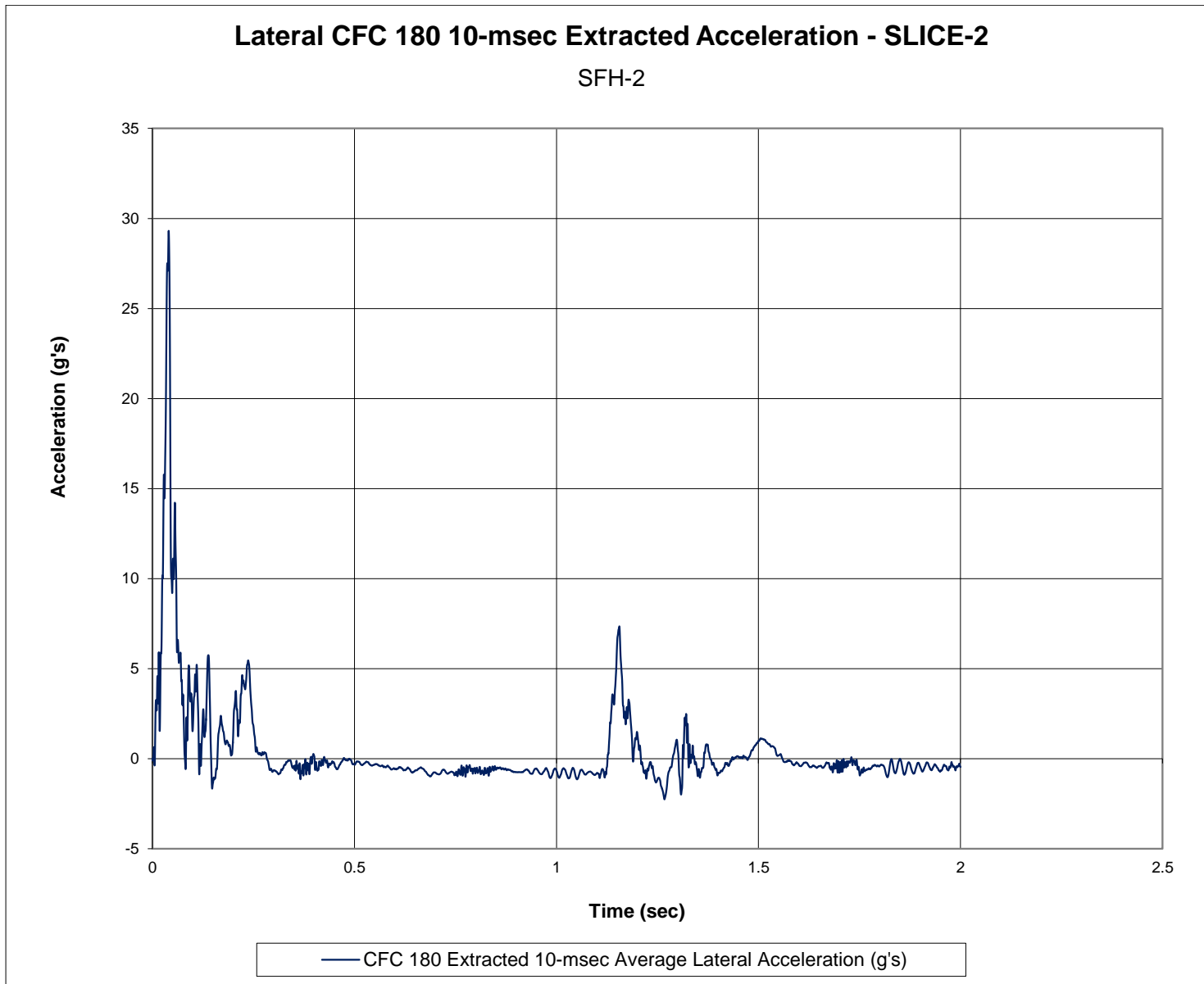

Figure E-12. 10-ms Average Lateral Deceleration (SLICE-2), Test No. SFH-2

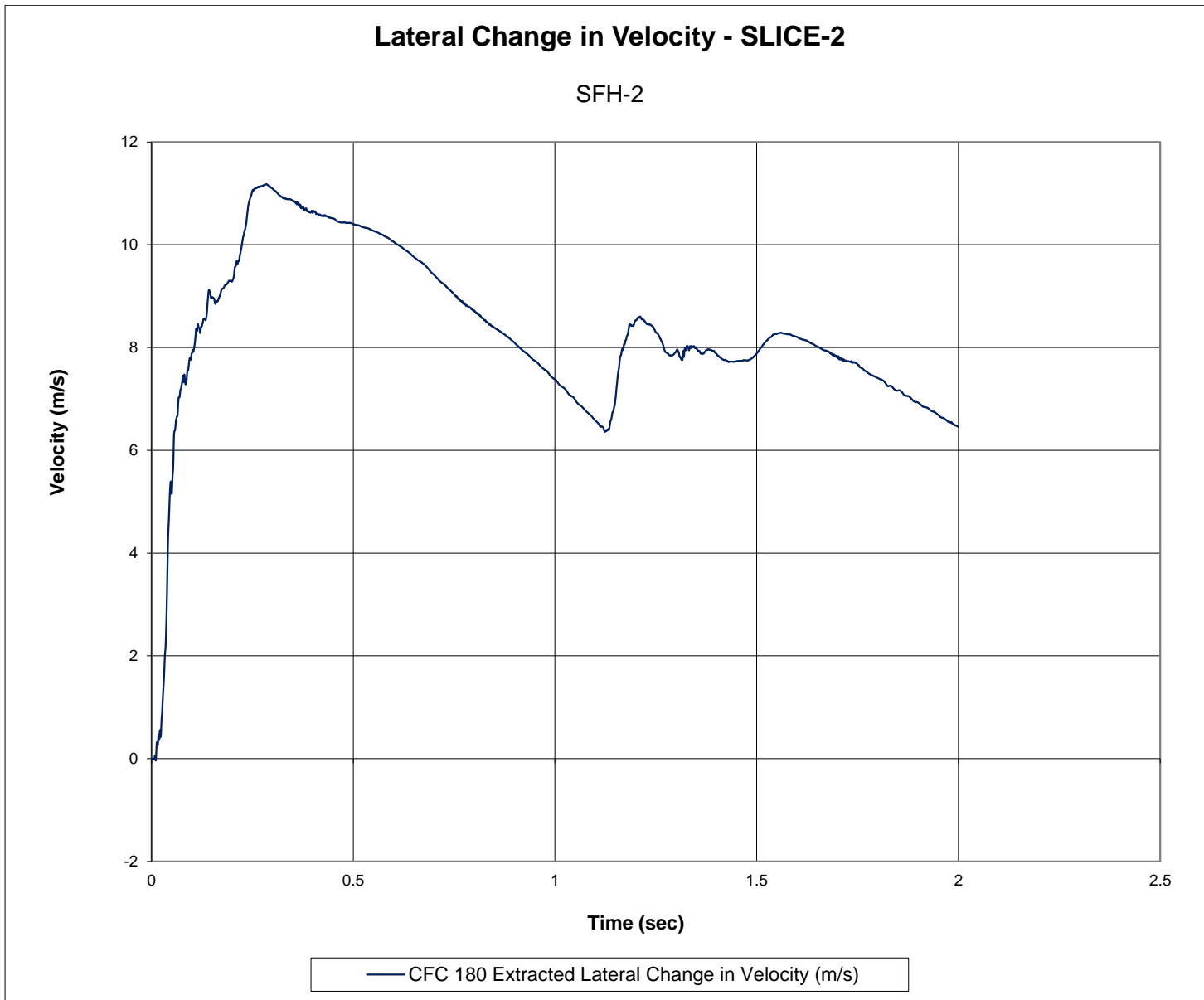

Figure E-13. Lateral Occupant Impact Velocity (SLICE-2), Test No. SFH-2

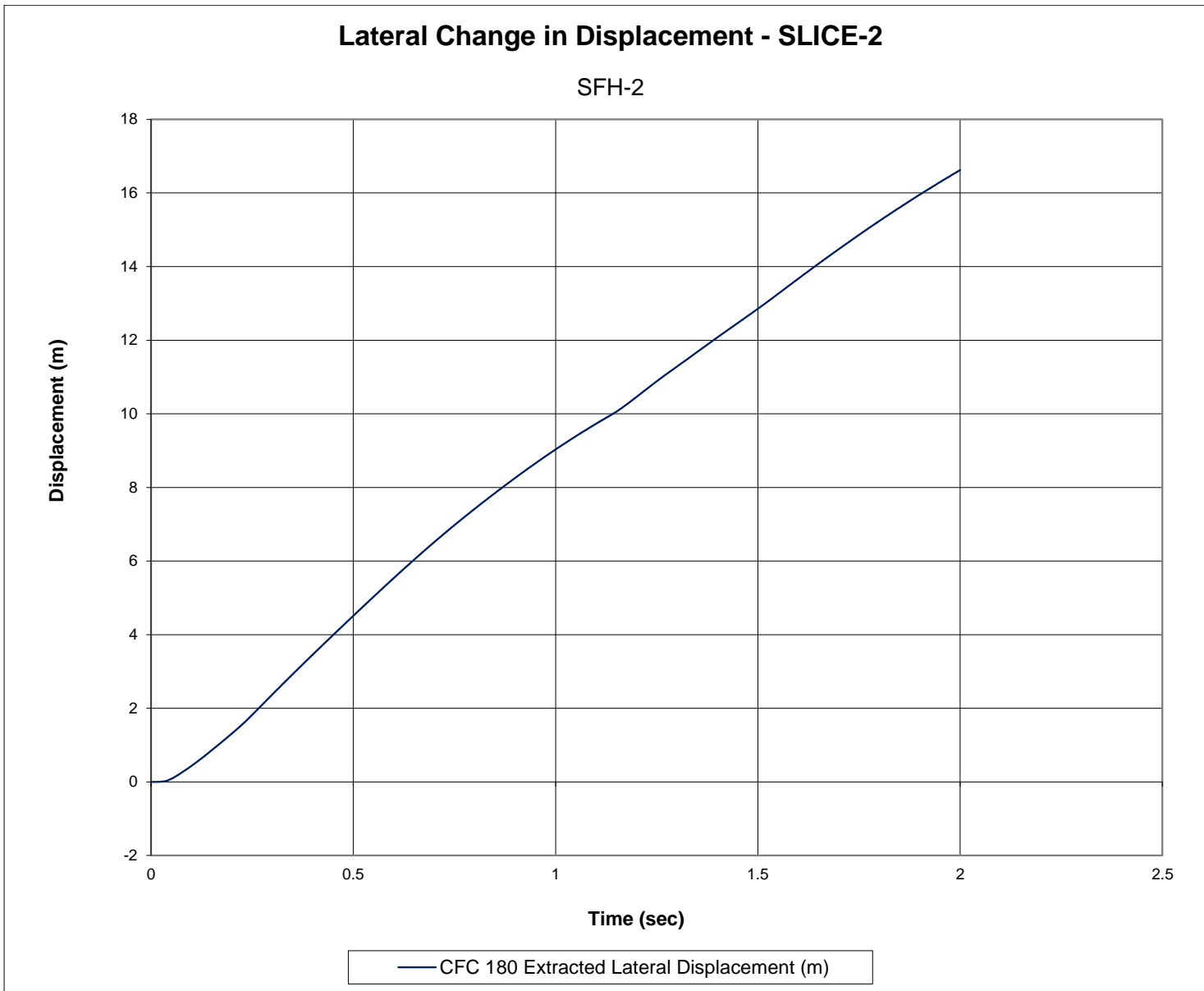

Figure E-14. Lateral Occupant Displacement (SLICE-2), Test No. SFH-2

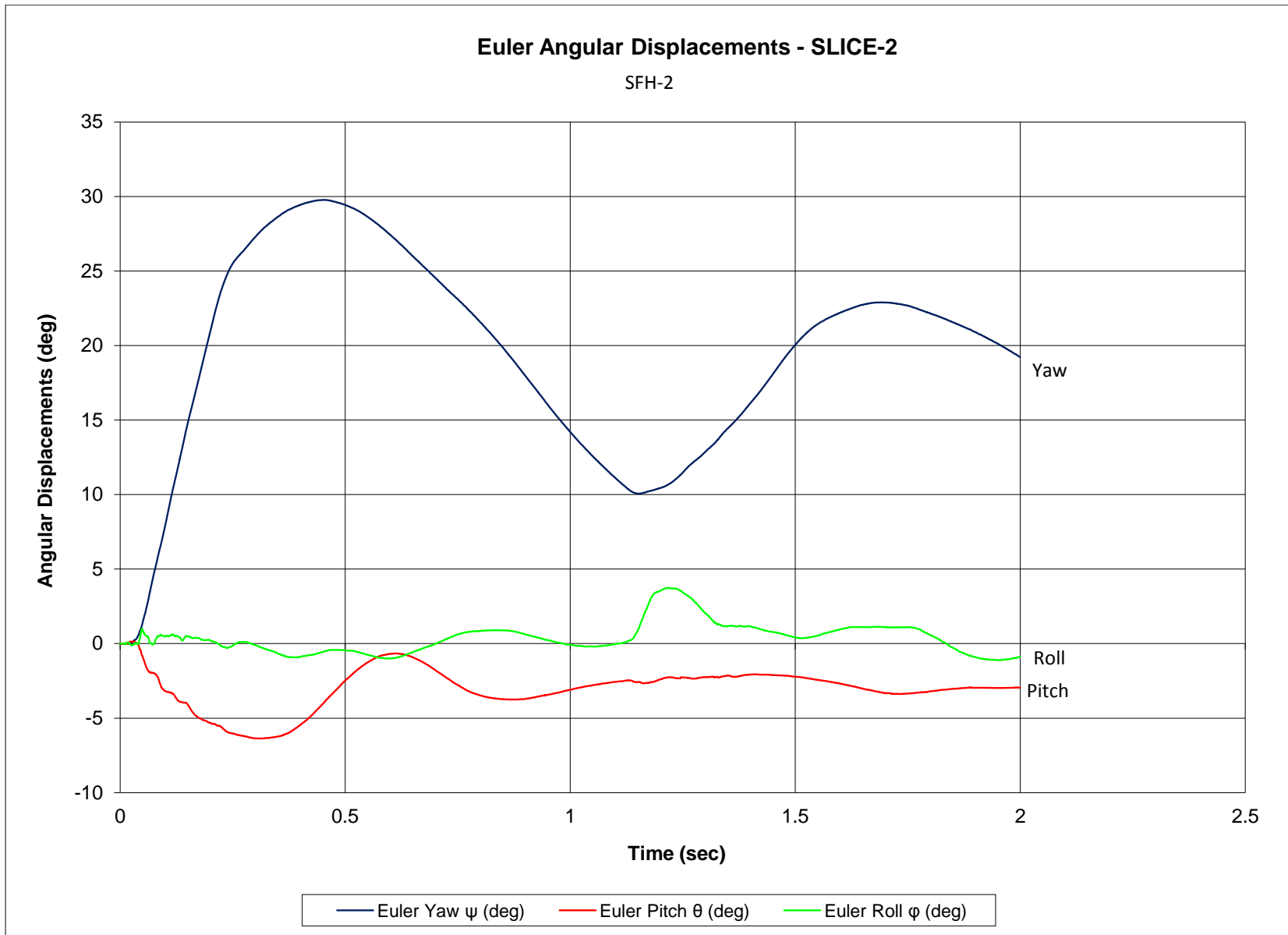

Figure E-15. Vehicle Angular Displacements (SLICE-2), Test No. SFH-2

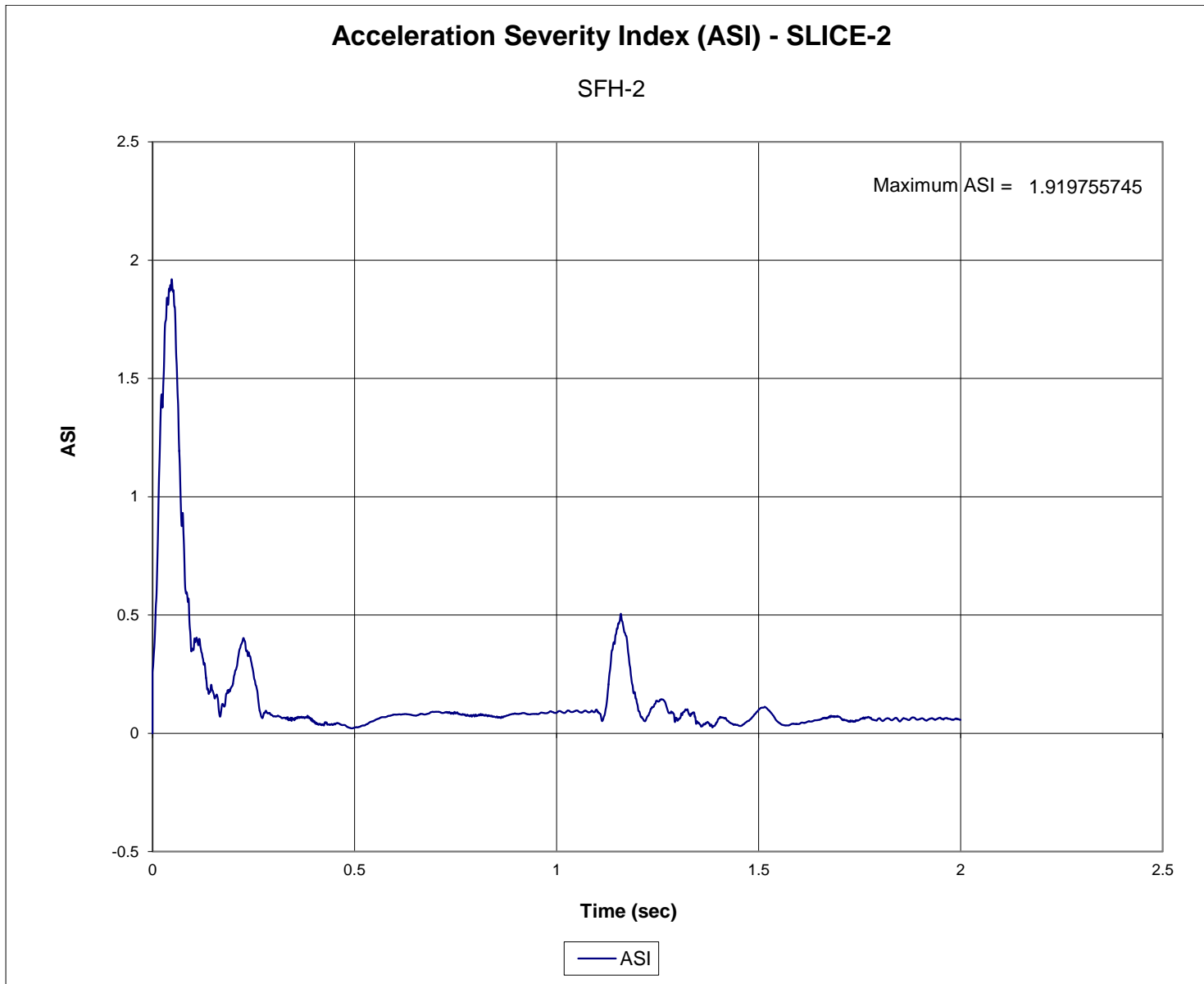

Figure E-16. Acceleration Severity Index (SLICE-2), Test No. SFH-2

Appendix F. Accelerometer and Rate Transducer Data Plots, Test No. SFH-3

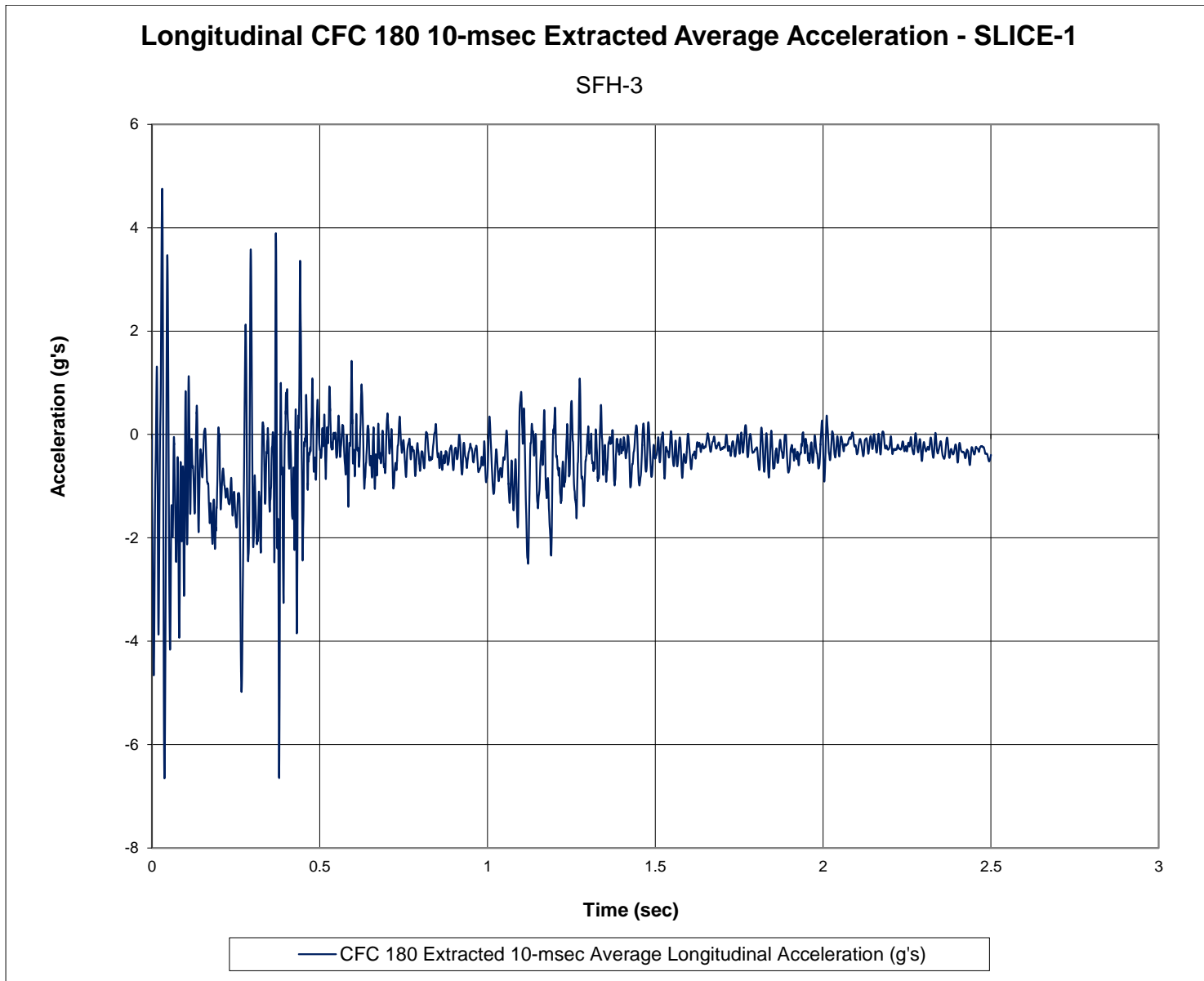

Figure F-1. 10-ms Average Longitudinal Deceleration (SLICE-1), Test No. SFH-3

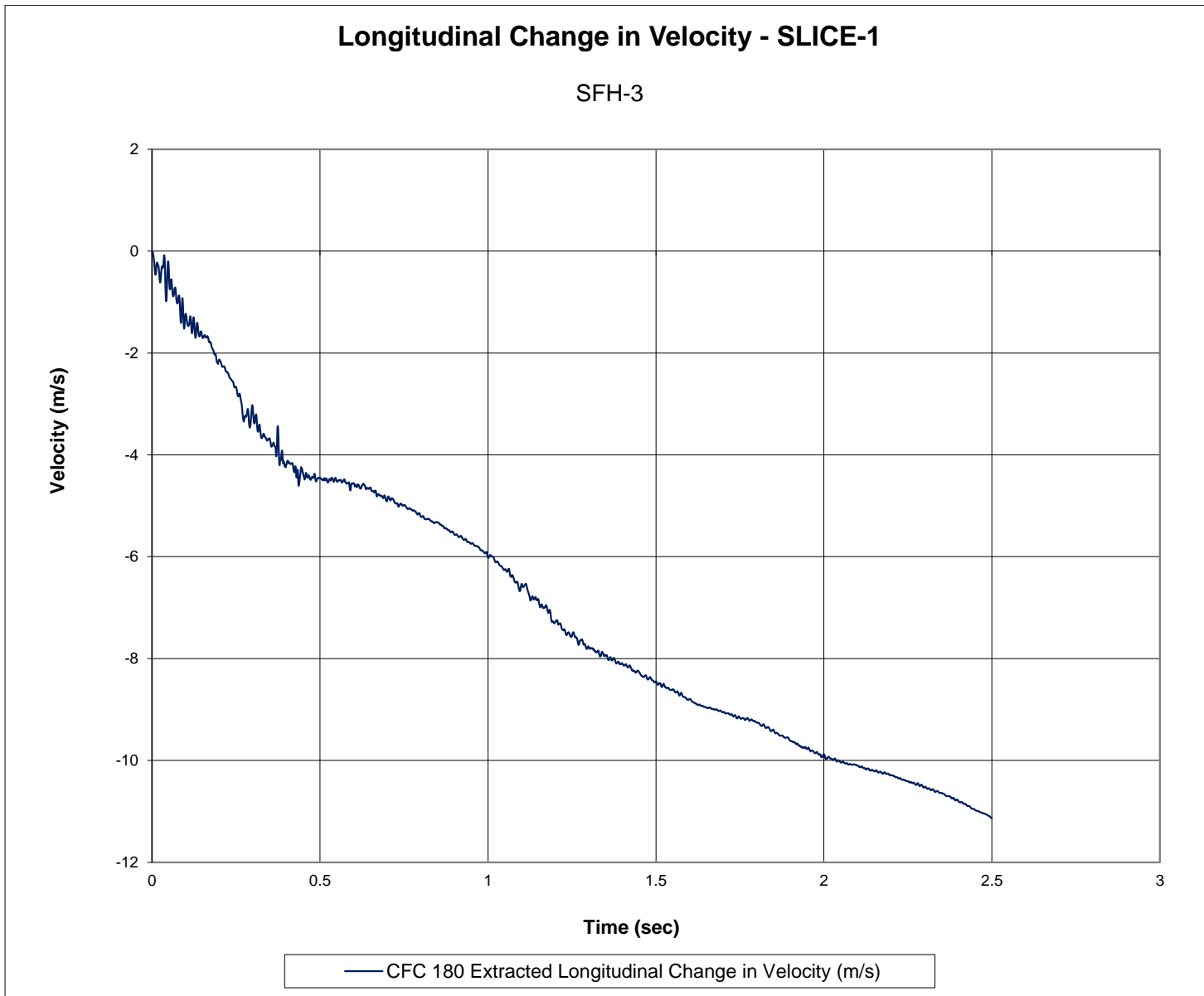

Figure F-2. Longitudinal Occupant Impact Velocity (SLICE-1), Test No. SFH-3

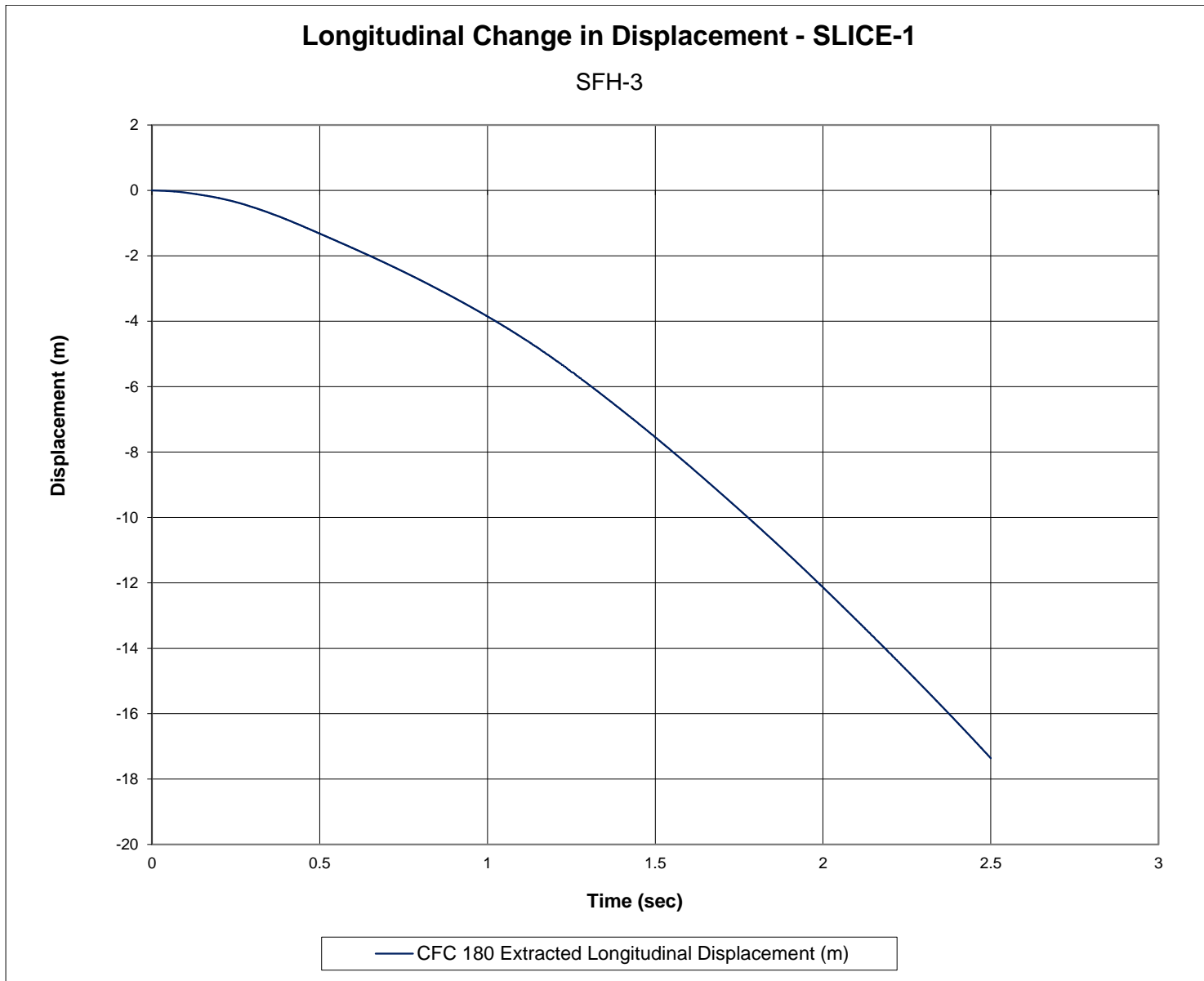

Figure F-3. Longitudinal Occupant Displacement (SLICE-1), Test No. SFH-3

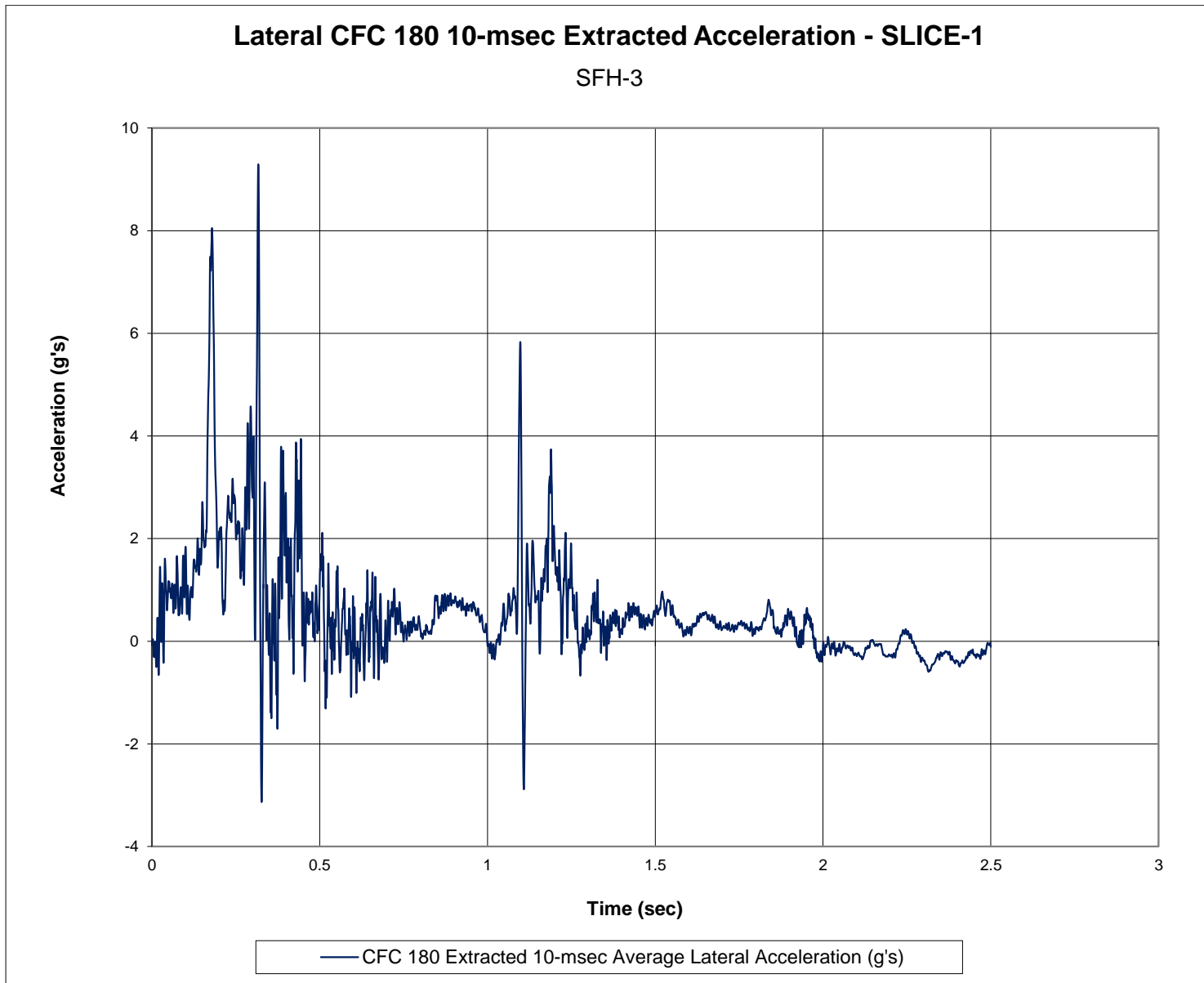

Figure F-4. 10-ms Average Lateral Deceleration (SLICE-1), Test No. SFH-3

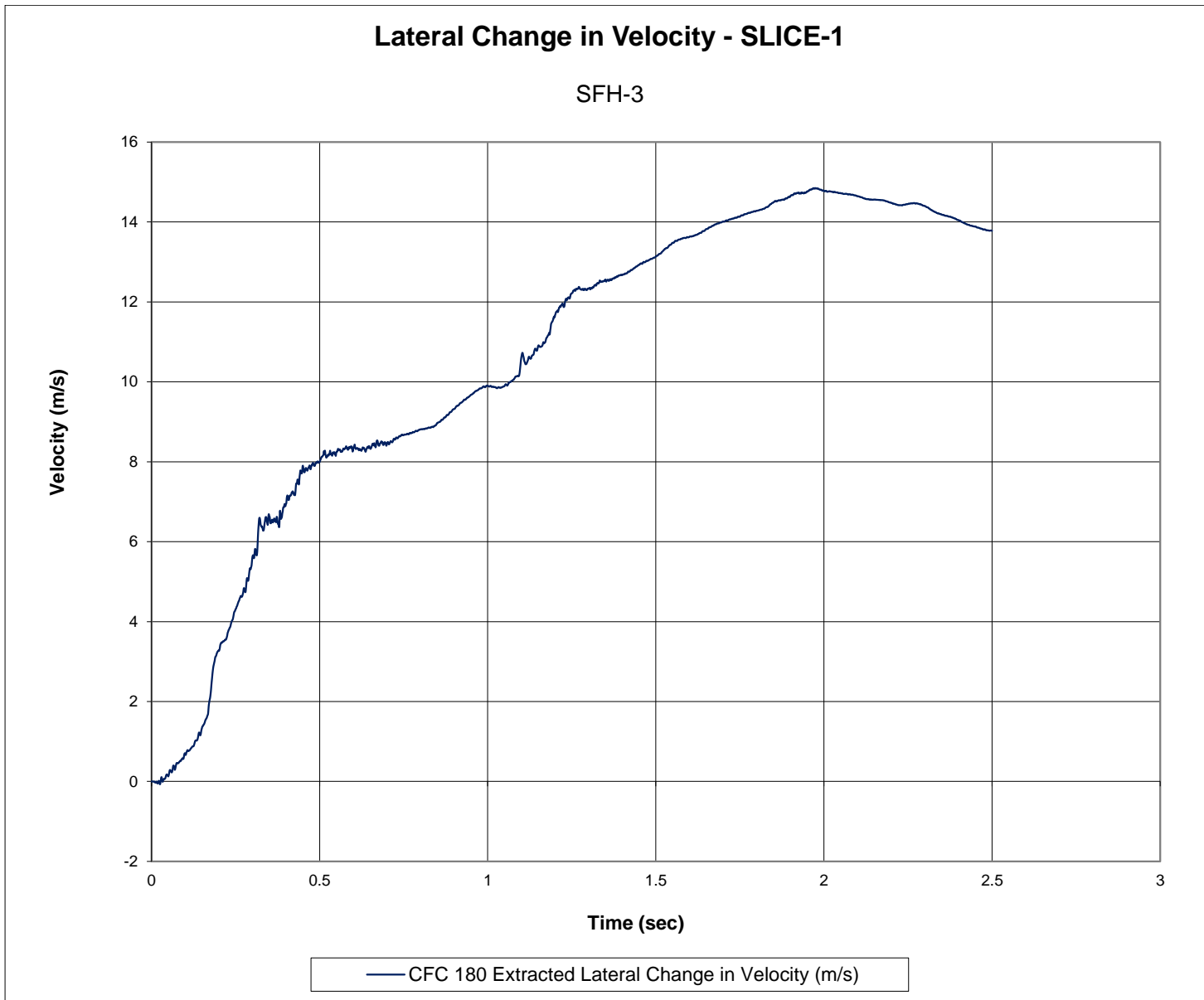

Figure F-5. Lateral Occupant Impact Velocity (SLICE-1), Test No. SFH-3

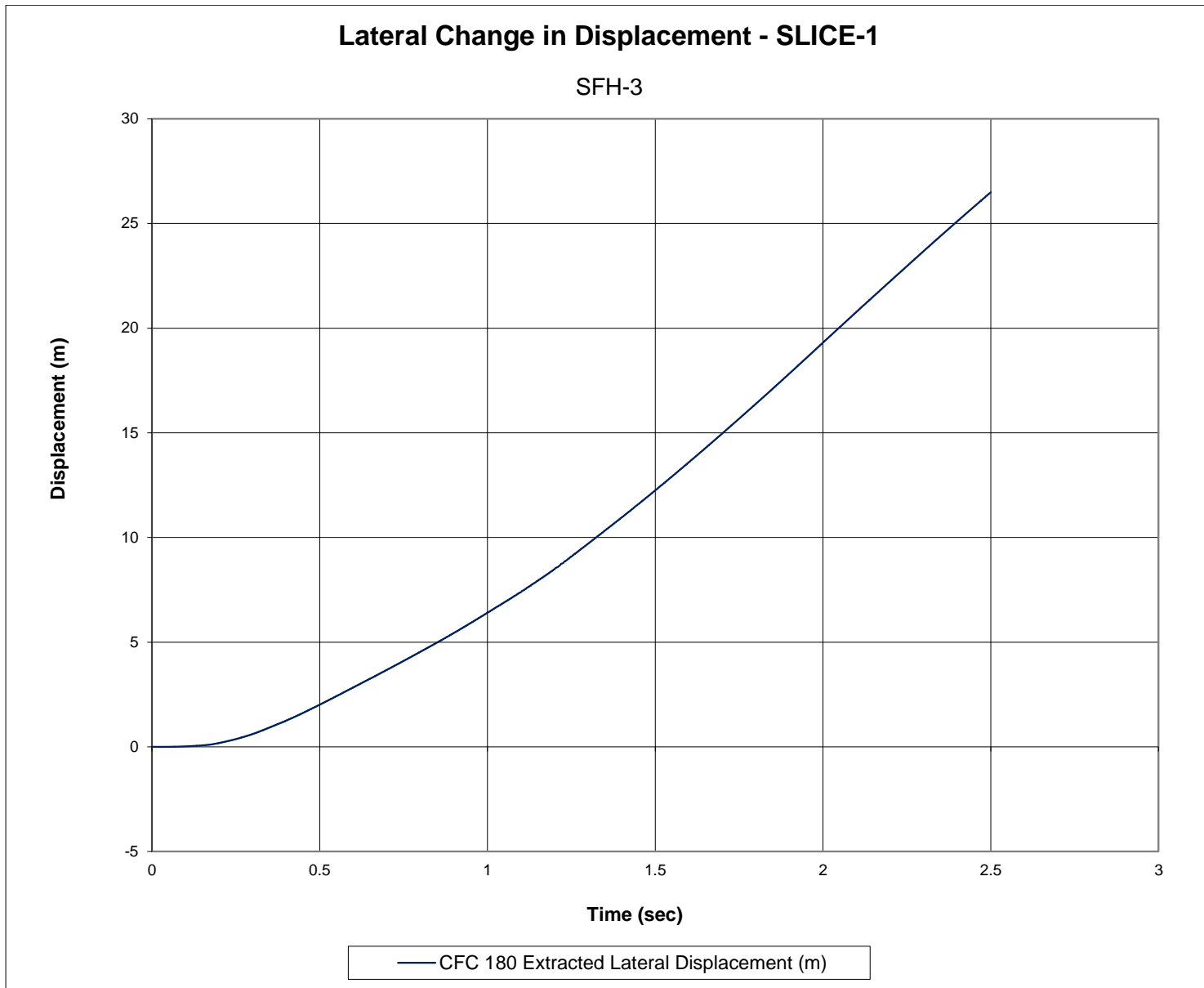

Figure F-6. Lateral Occupant Displacement (SLICE-1), Test No. SFH-3

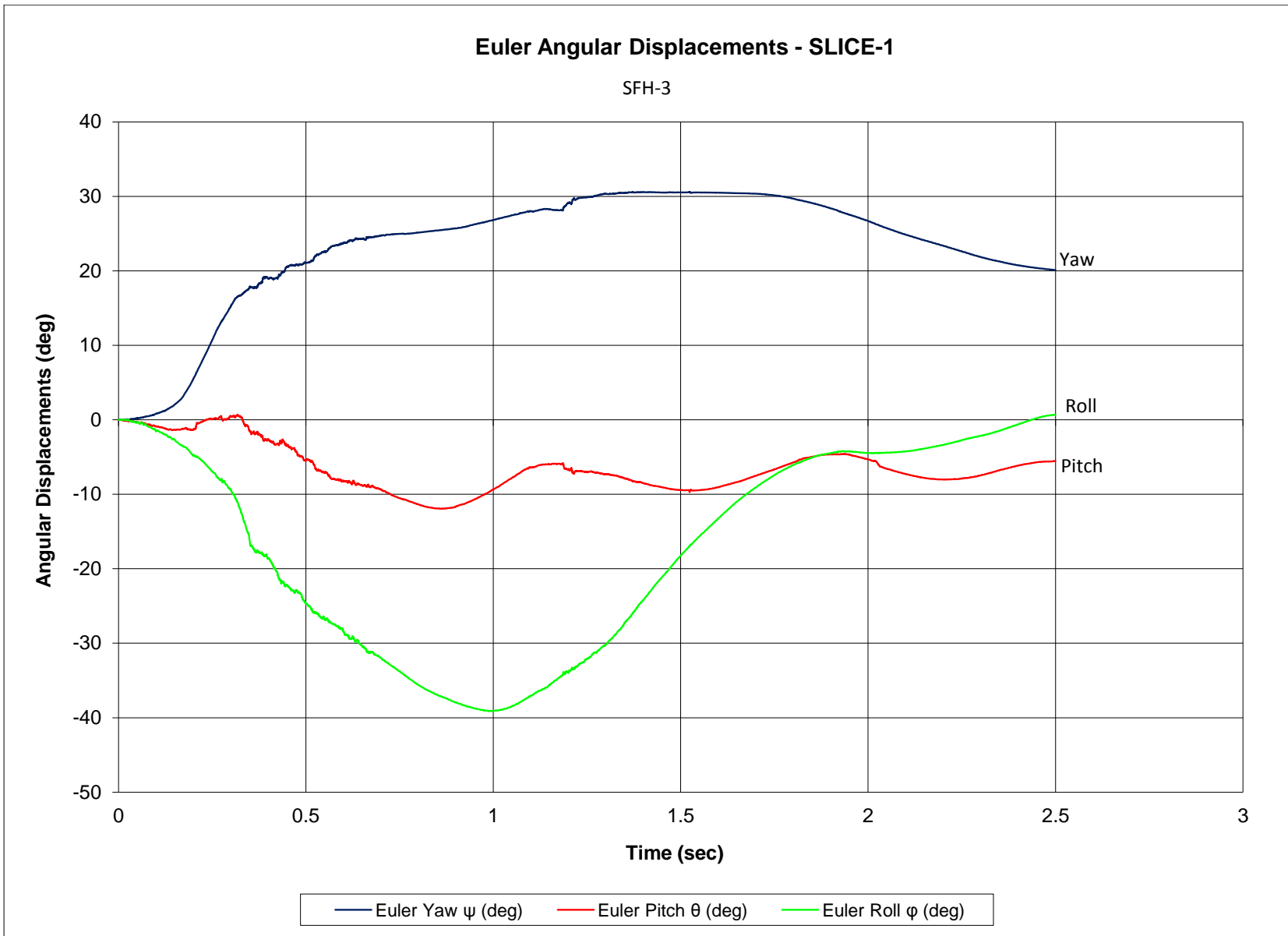

Figure F-7. Vehicle Angular Displacements (SLICE-1), Test No. SFH-3

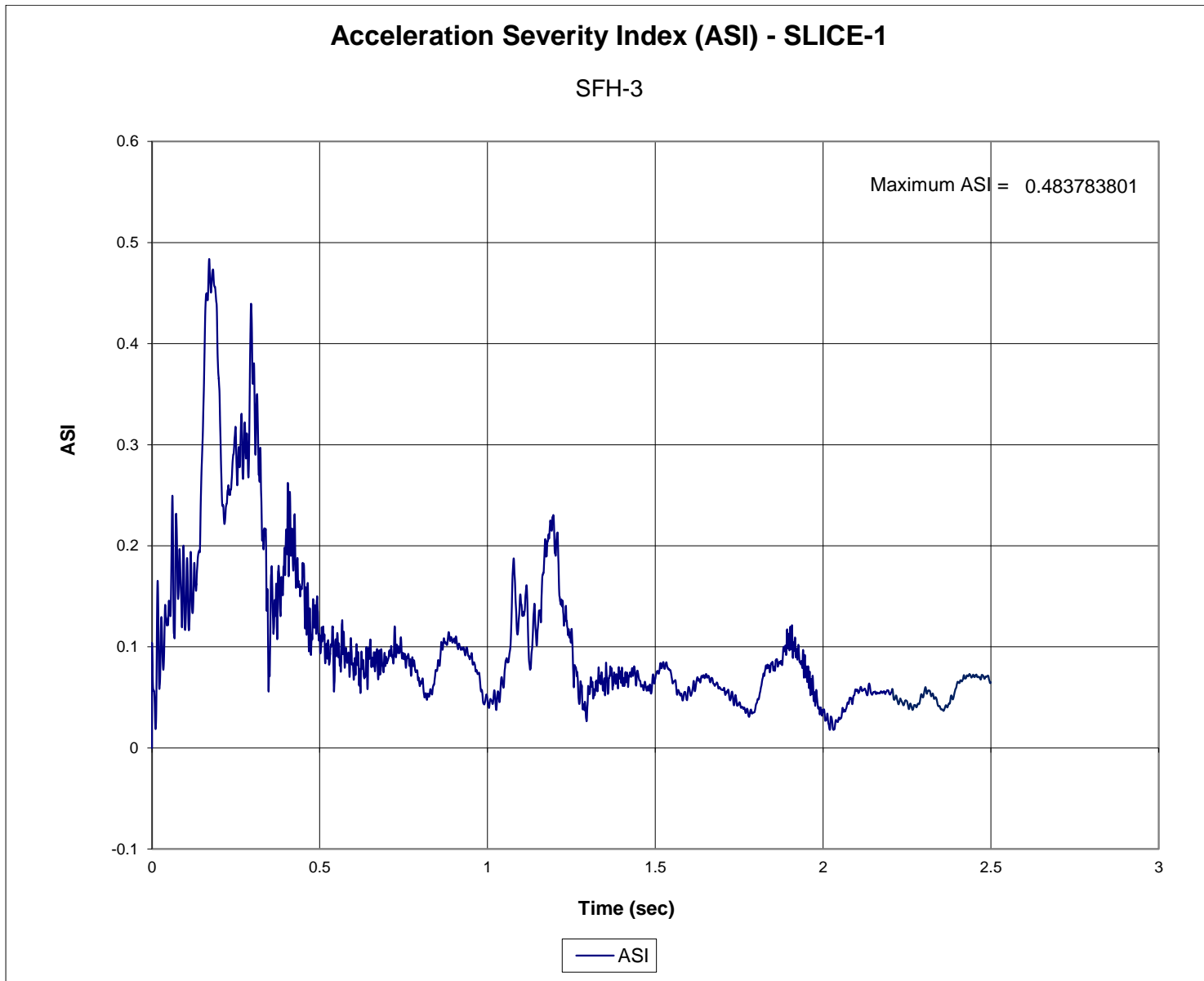

Figure F-8. Acceleration Severity Index (SLICE-1), Test No. SFH-3

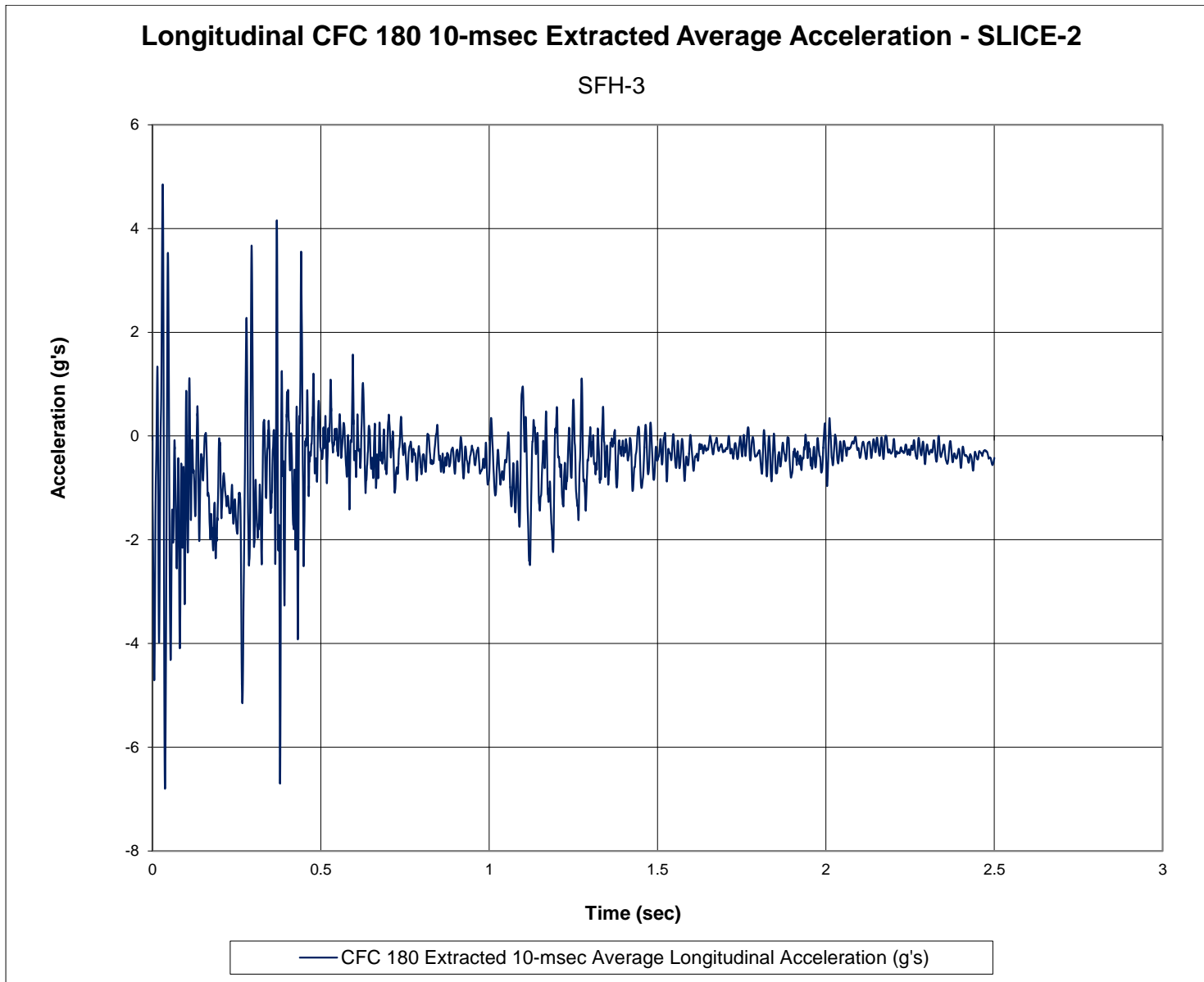

Figure F-9. 10-ms Average Longitudinal Deceleration (SLICE-2), Test No. SFH-3

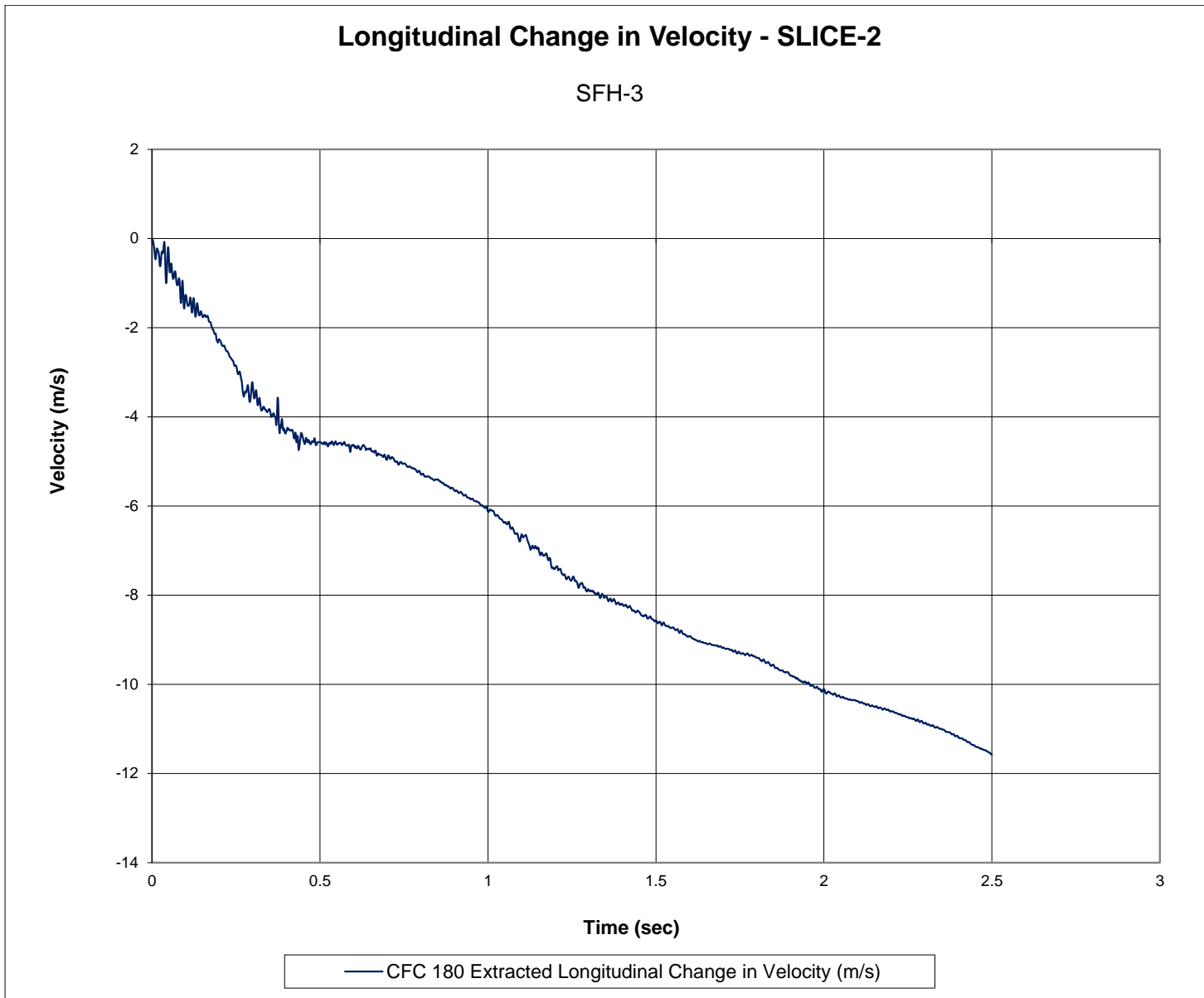

Figure F-10. Longitudinal Occupant Impact Velocity (SLICE-2), Test No. SFH-3

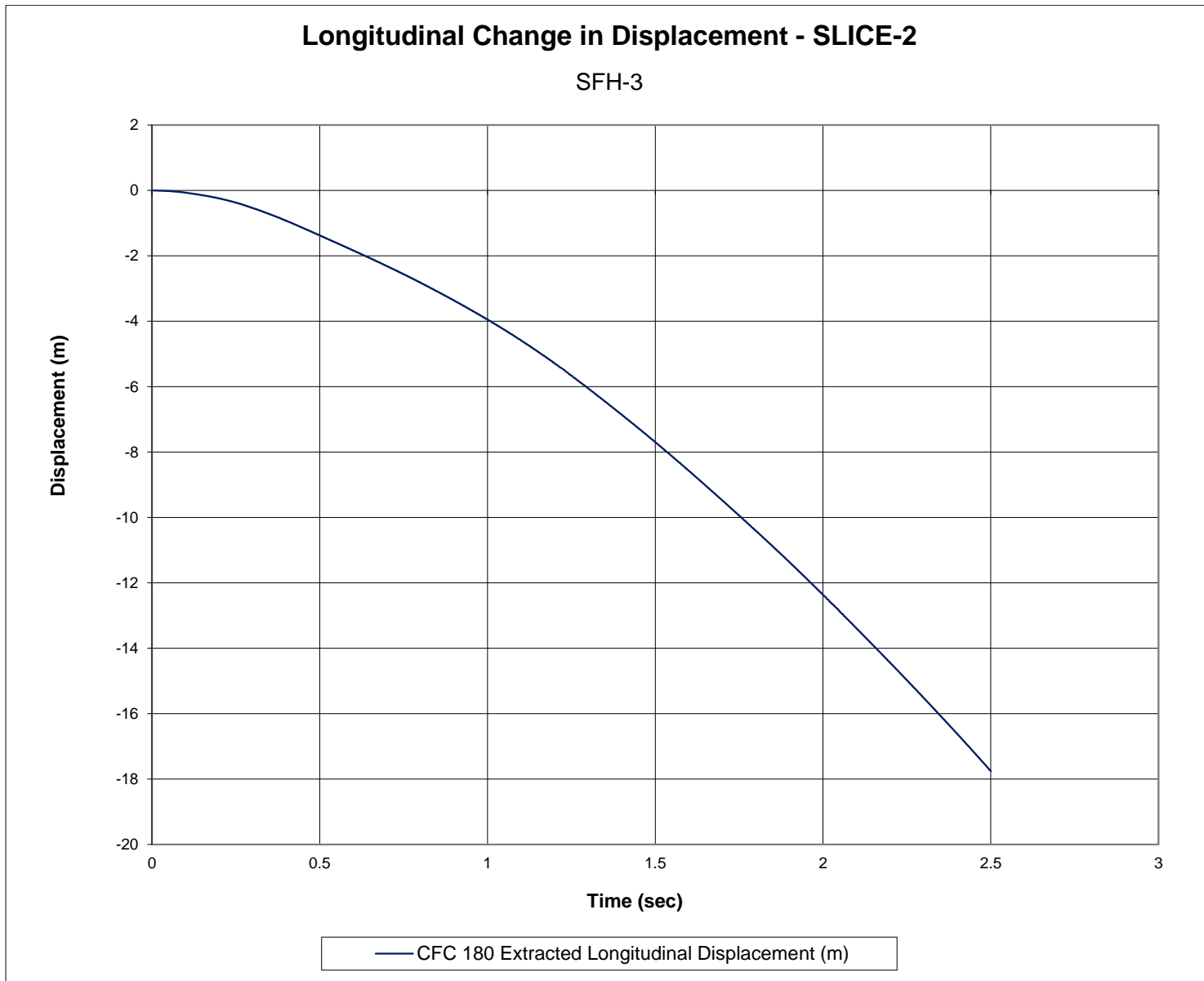

Figure F-11. Longitudinal Occupant Displacement (SLICE-2), Test No. SFH-3

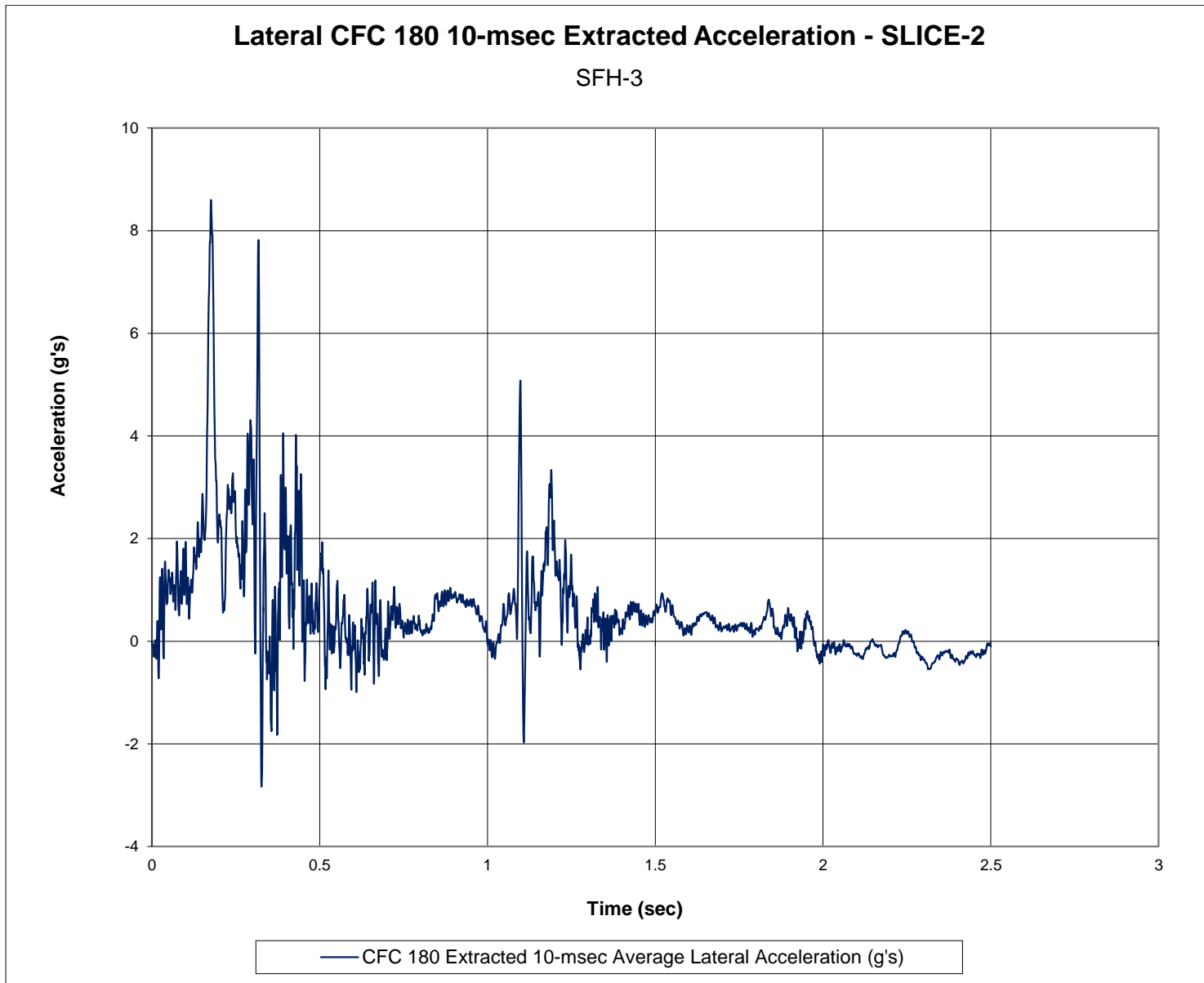

Figure F-12. 10-ms Average Lateral Deceleration (SLICE-2), Test No. SFH-3

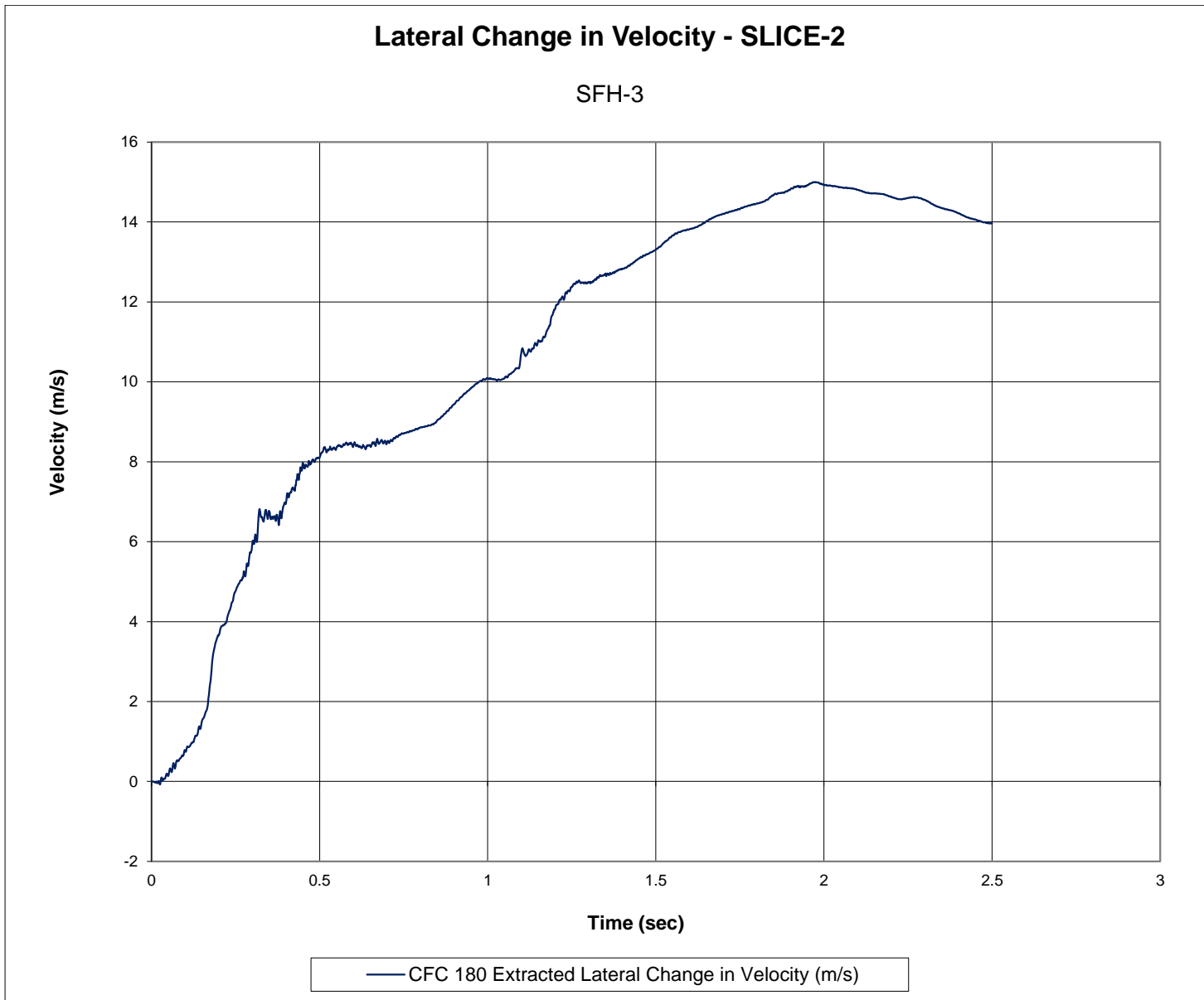

Figure F-13. Lateral Occupant Impact Velocity (SLICE-2), Test No. SFH-3

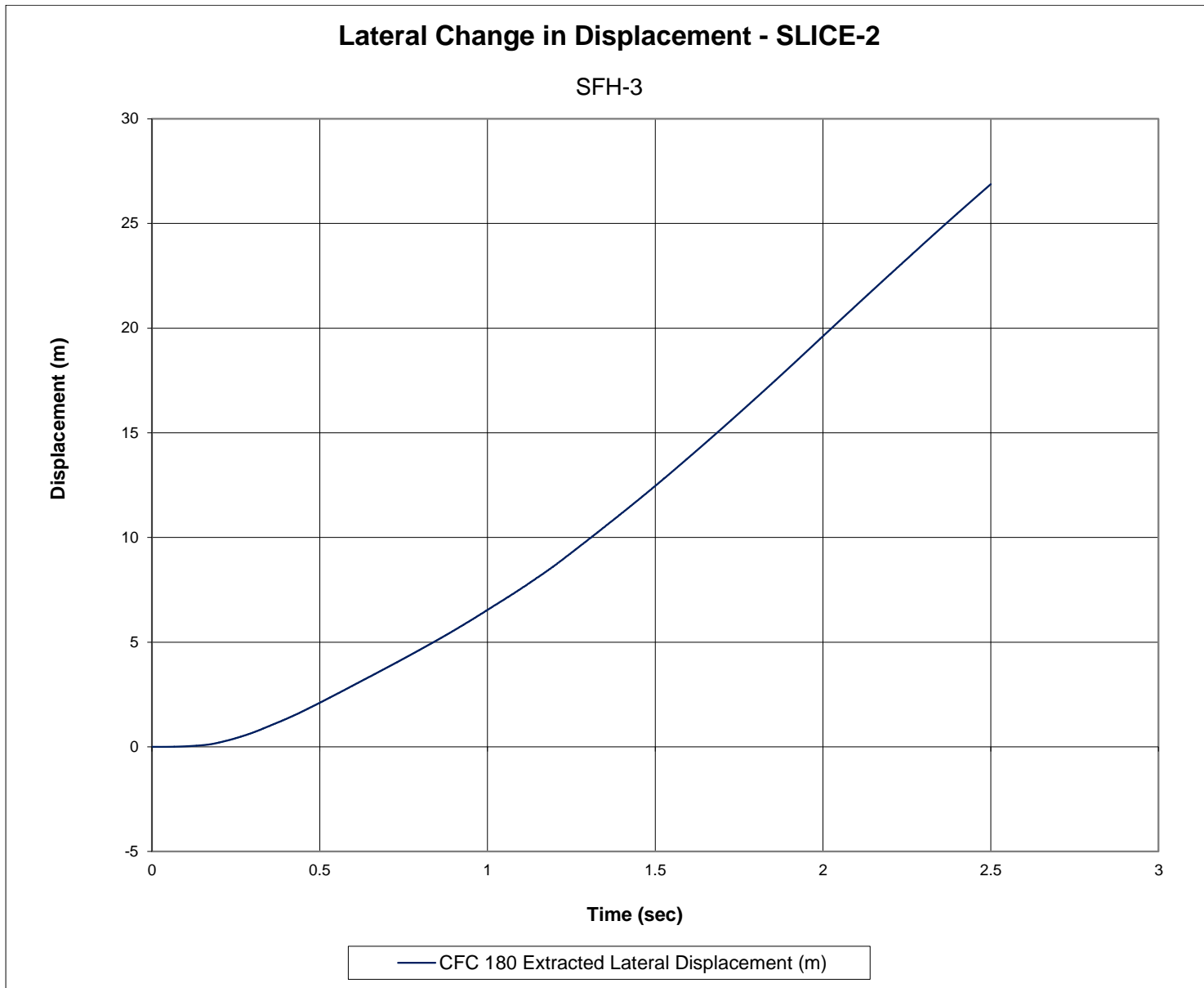

Figure F-14. Lateral Occupant Displacement (SLICE-2), Test No. SFH-3

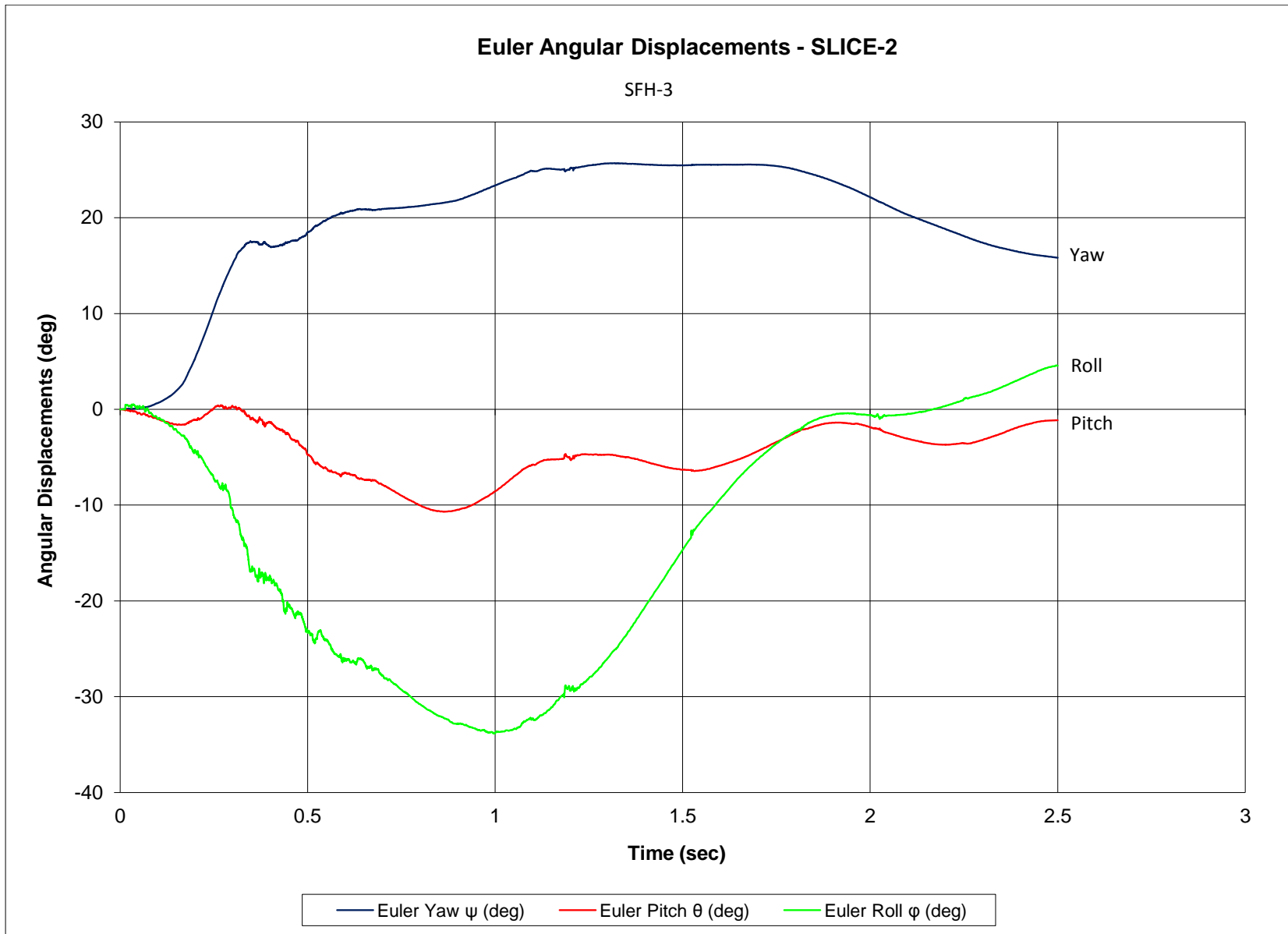

Figure F-15. Vehicle Angular Displacements (SLICE-2), Test No. SFH-3

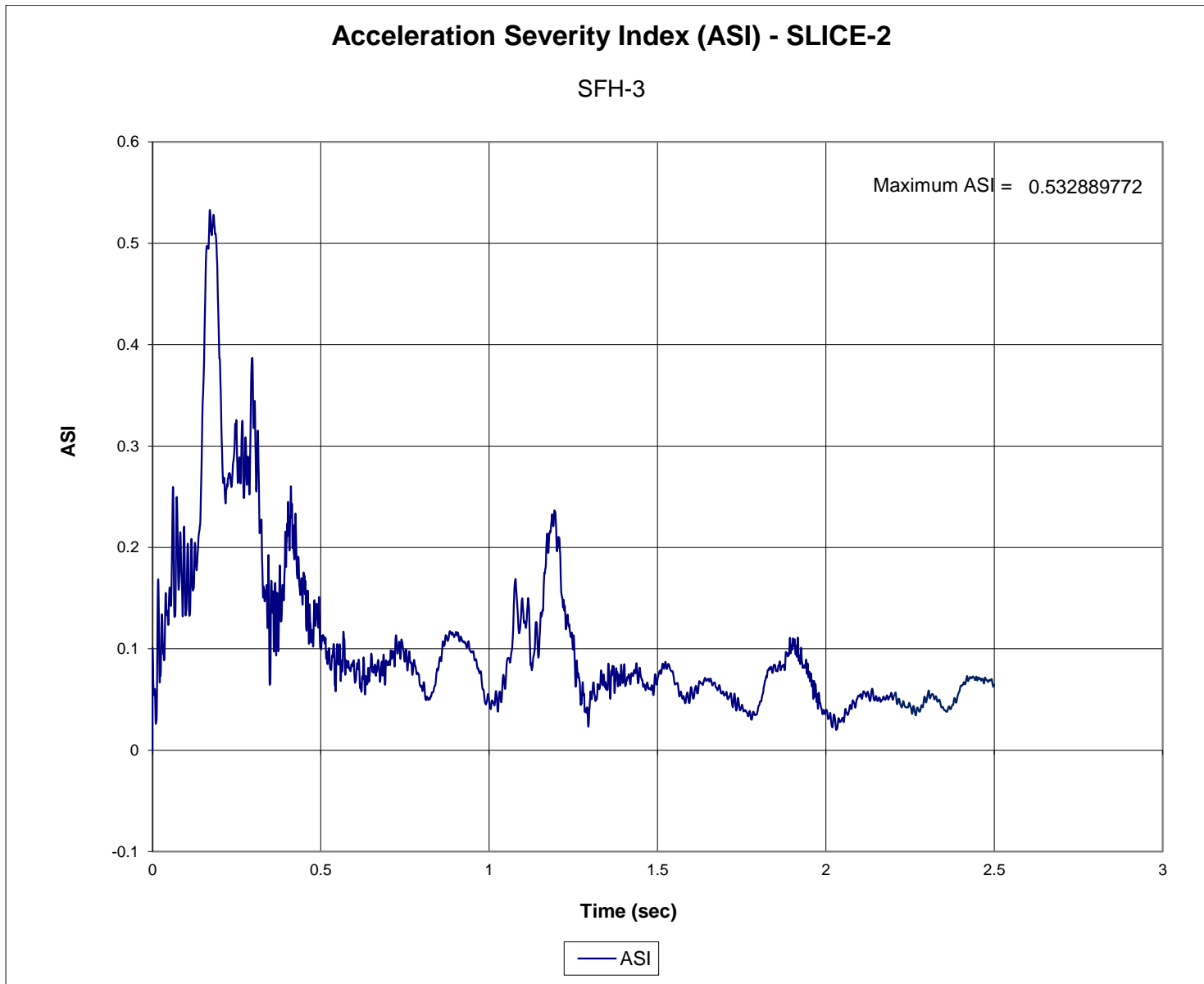

Figure F-16. Acceleration Severity Index (SLICE-2), Test No. SFH-3

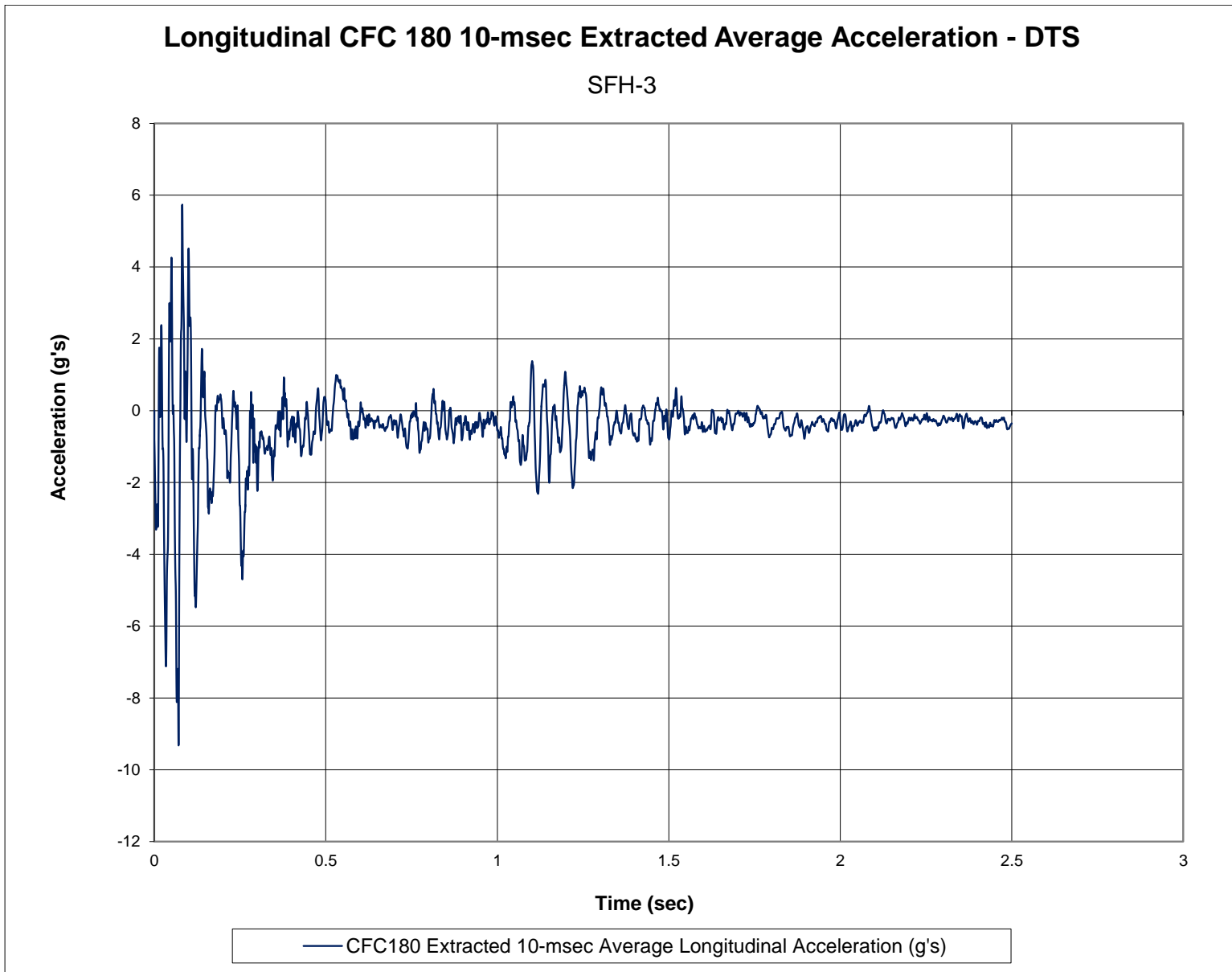

Figure F-17. 10-ms Average Longitudinal Deceleration (DTS), Test No. SFH-3

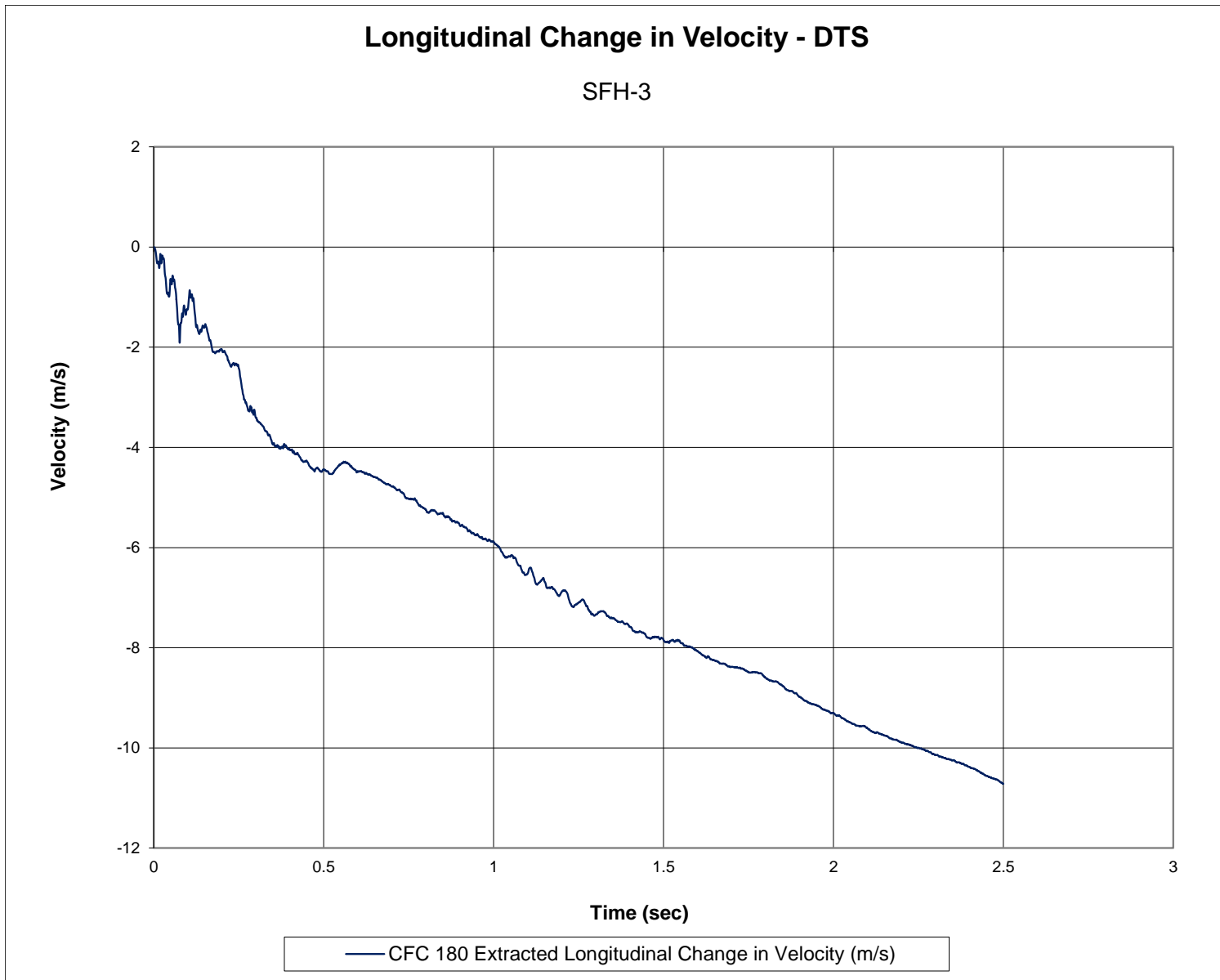

Figure F-18. Longitudinal Occupant Impact Velocity (DTS), Test No. SFH-3

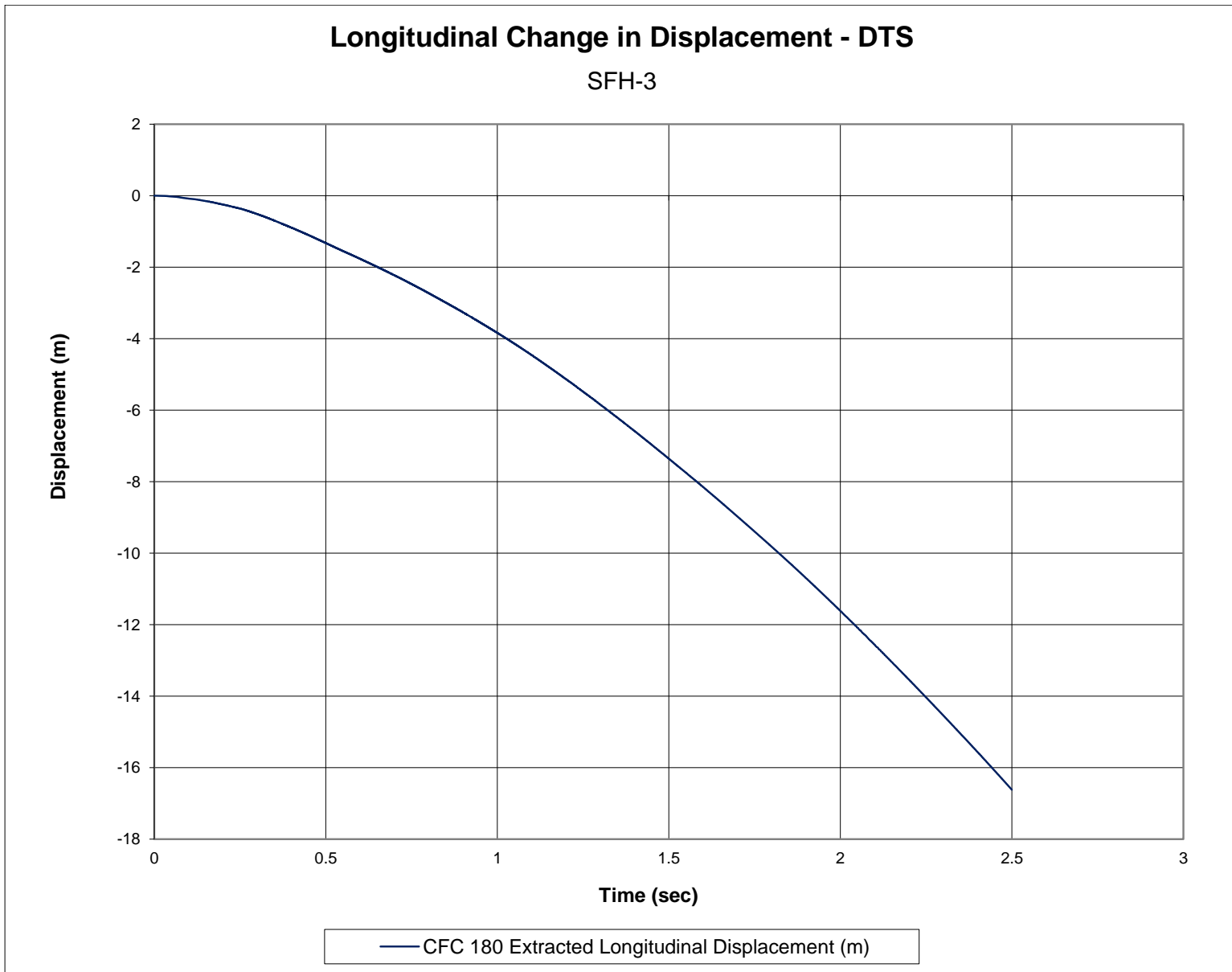

Figure F-19. Longitudinal Occupant Displacement (DTS), Test No. SFH-3

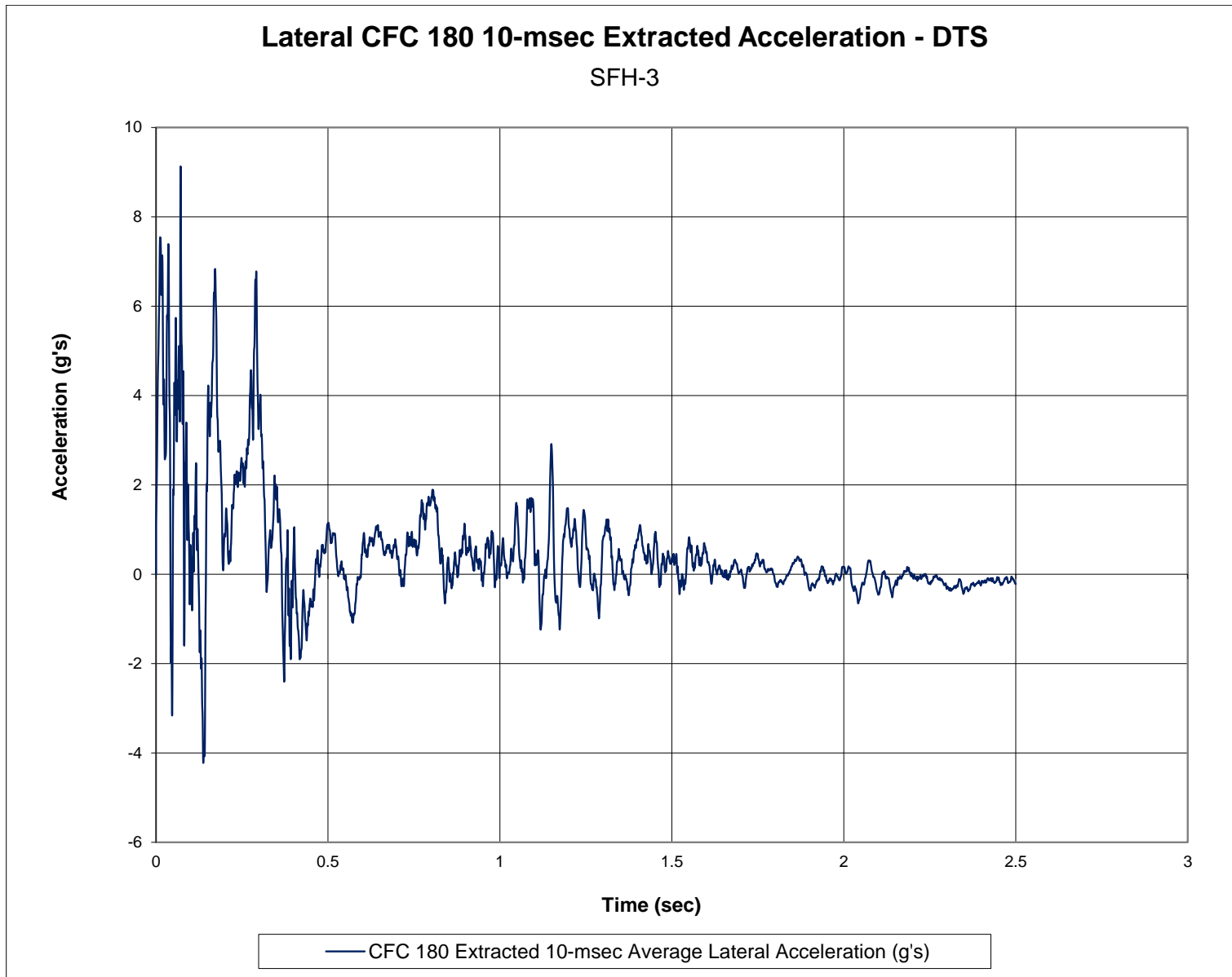

Figure F-20. 10-ms Average Lateral Deceleration (DTS), Test No. SFH-3

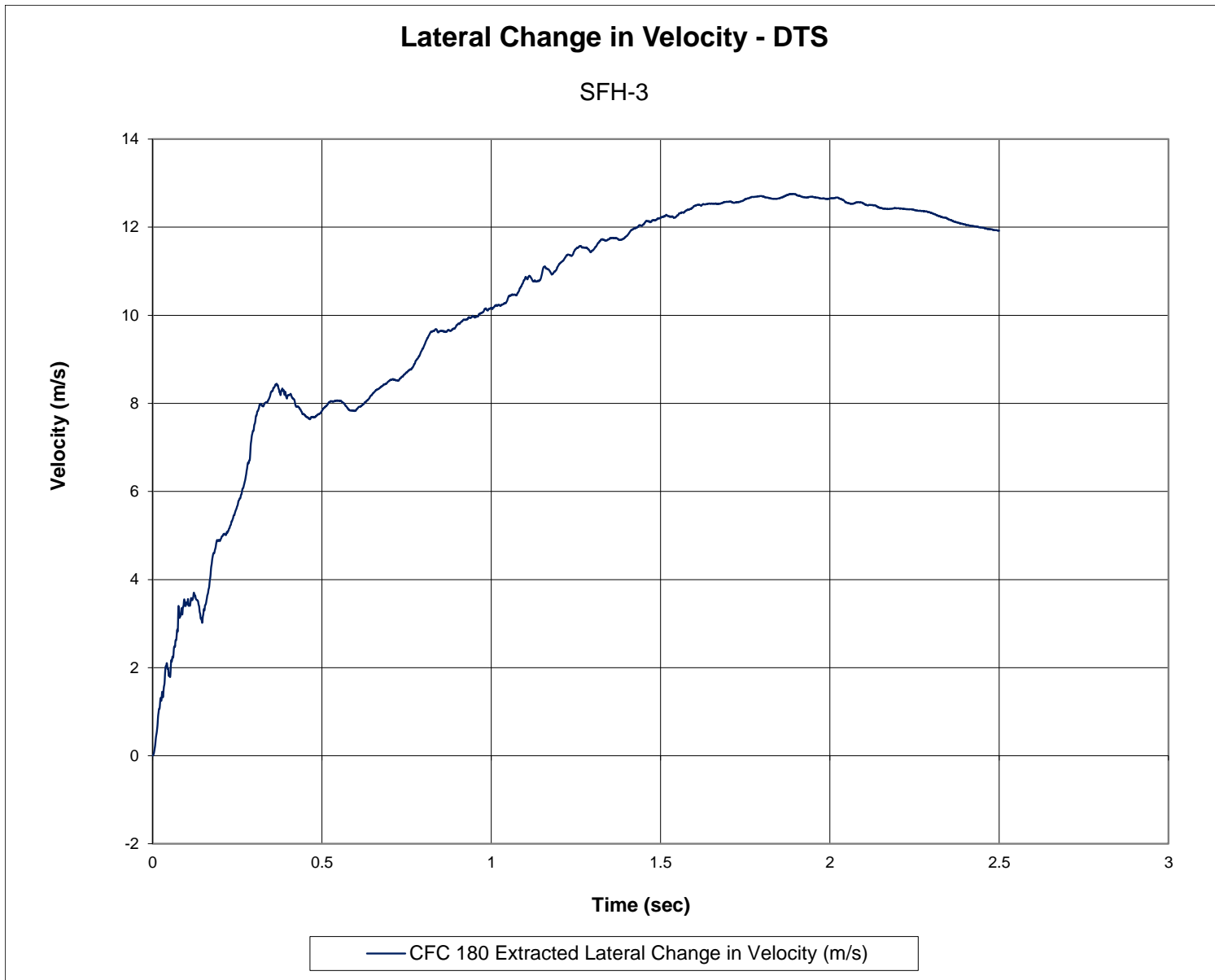

Figure F-21. Lateral Occupant Impact Velocity (DTS), Test No. SFH-3

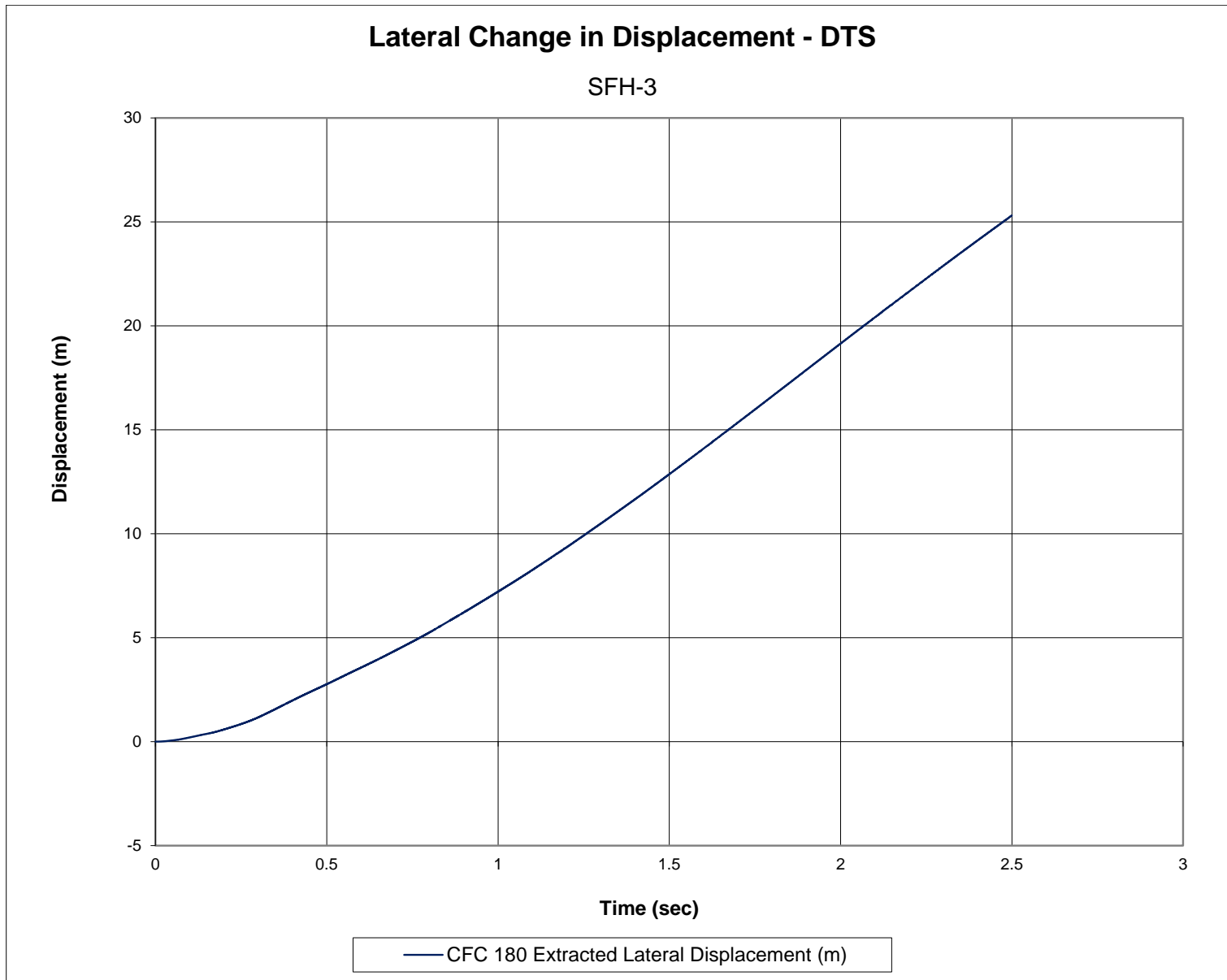

Figure F-22. Lateral Occupant Displacement (DTS), Test No. SFH-3

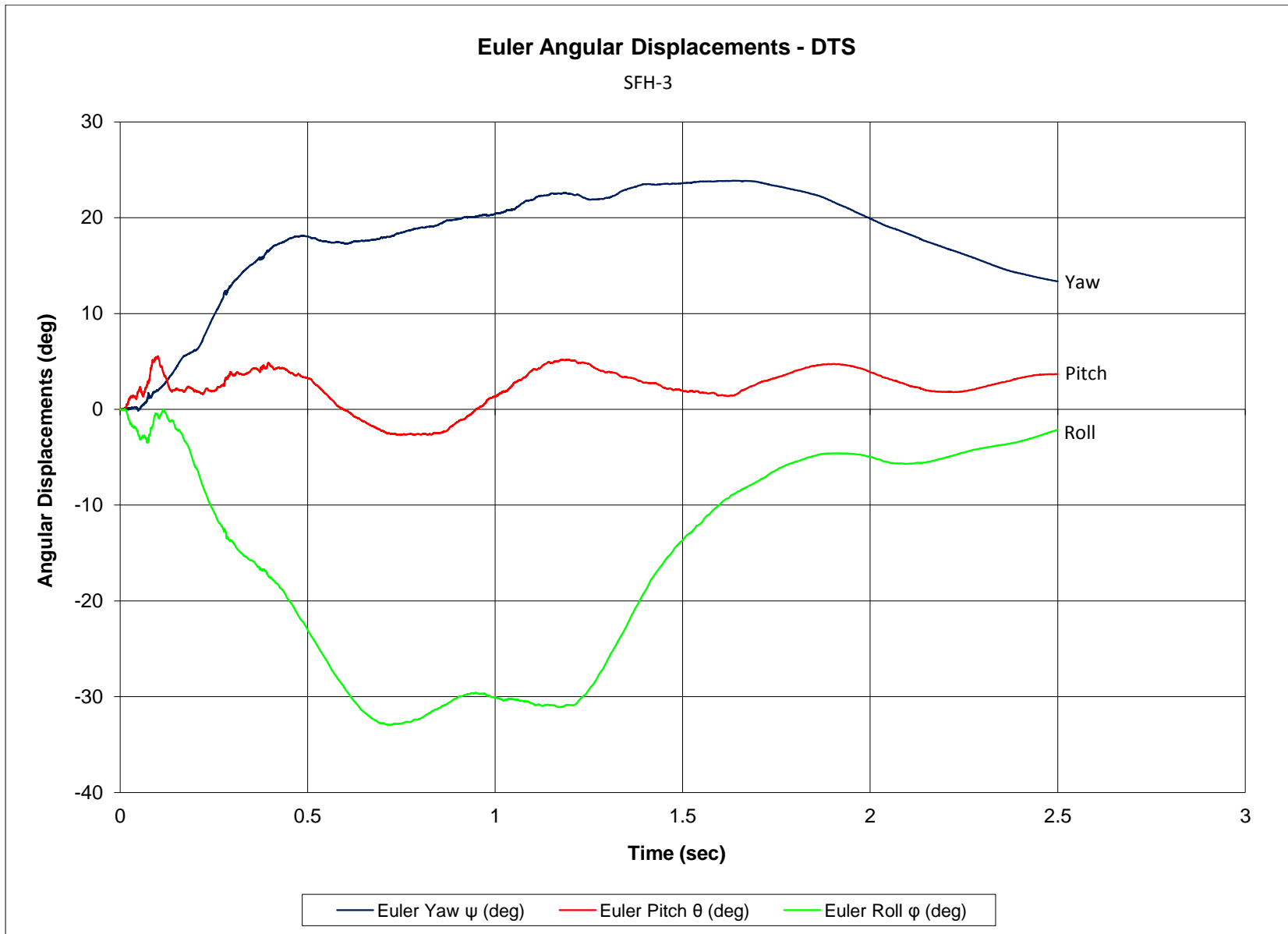

Figure F-23. Vehicle Angular Displacements (DTS), Test No. SFH-3

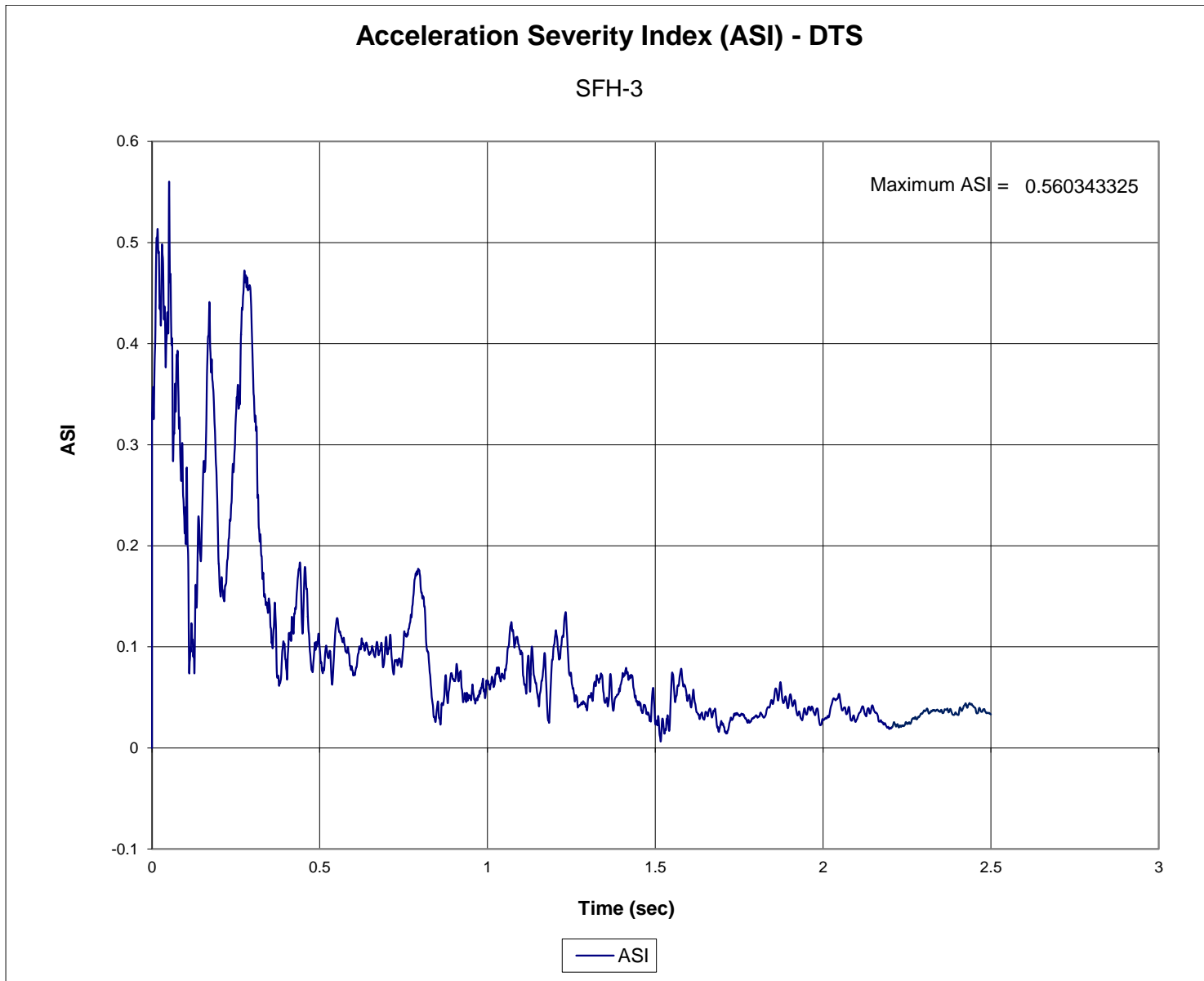

Figure F-24. Acceleration Severity Index (DTS), Test No. SFH-3

END OF DOCUMENT