



U.S. Department
of Transportation
**Federal Highway
Administration**

1200 New Jersey Ave., SE
Washington, D.C. 20590

February 14, 2017

In Reply Refer To:
HSST-1/B-278

Ms. Maggie Ellis
Mondo Polymer Technologies, Inc.
P.O. Box 250
Reno, OH 45773

Dear Ms. Ellis:

This letter is in response to your January 6, 2017 request for the Federal Highway Administration (FHWA) to review a roadside safety device, hardware, or system for eligibility for reimbursement under the Federal-aid highway program. This FHWA letter of eligibility is assigned FHWA control number B-278 and is valid until a subsequent letter is issued by FHWA that expressly references this device.

Decision

The following devices are eligible, with details provided in the form which is attached as an integral part of this letter:

- Mondo Polymer 8-inch Composite Blockout with cut-outs (Model #GB14SH2) for Steel post Midwest Guardrail System (MGS)

Scope of this Letter

To be found eligible for Federal-aid funding, new roadside safety devices should meet the crash test and evaluation criteria contained in the American Association of State Highway and Transportation Officials' (AASHTO) Manual for Assessing Safety Hardware (MASH). However, the FHWA, the Department of Transportation, and the United States Government do not regulate the manufacture of roadside safety devices. Eligibility for reimbursement under the Federal-aid highway program does not establish approval, certification or endorsement of the device for any particular purpose or use.

This letter is not a determination by the FHWA, the Department of Transportation, or the United States Government that a vehicle crash involving the device will result in any particular outcome, nor is it a guarantee of the in-service performance of this device. Proper manufacturing, installation, and maintenance are required in order for this device to function as tested.

This finding of eligibility is limited to the crashworthiness of the system and does not cover other structural features, nor conformity with the Manual on Uniform Traffic Control Devices.

Eligibility for Reimbursement

Based solely on a review of crash test results and certifications submitted by the manufacturer, and the crash test laboratory, FHWA agrees that the device described herein meets the crash test and evaluation criteria of the AASHTO's Manual for Assessing Safety Hardware (MASH). Therefore, the device is eligible for reimbursement under the Federal-aid highway program if installed under the range of tested conditions.

Name of system: Mondo Polymer 8-inch Composite Blockout with cut-outs (Model #GB14SH2) for Steel post Midwest Guardrail System (MGS)

Type of system: Longitudinal Barrier

Test Level: MASH Test Level 3 (TL3)

Testing conducted by: Texas A&M Transportation Institute

Date of request: November 23, 2016

Date initially acknowledged: November 30, 2016

Date of completed package: January 6, 2017

FHWA concurs with the recommendation of the accredited crash testing laboratory as stated within the attached form.

Full Description of the Eligible Device

The device and supporting documentation, including reports of the crash tests or other testing done, videos of any crash testing, and/or drawings of the device, are described in the attached form.

Notice

If a manufacturer makes any modification to any of their roadside safety hardware that has an existing eligibility letter from FHWA, the manufacturer must notify FHWA of such modification with a request for continued eligibility for reimbursement. The notice of all modifications to a device must be accompanied by:

- Significant modifications – For these modifications, crash test results must be submitted with accompanying documentation and videos.
- Non-signification modifications – For these modifications, a statement from the crash test laboratory on the potential effect of the modification on the ability of the device to meet the relevant crash test criteria.

FHWA's determination of continued eligibility for the modified hardware will be based on whether the modified hardware will continue to meet the relevant crash test criteria.

Any user or agency relying on this eligibility letter is expected to use the same designs, specifications, drawings, installation and maintenance instructions as those submitted for review.

You are expected to certify to potential users that the hardware furnished has the same chemistry, mechanical properties, and geometry as that submitted for review, and that it will meet the test and evaluation criteria of the AASHTO MASH.

Issuance of this letter does not convey property rights of any sort or any exclusive privilege. This letter is based on the premise that information and reports submitted by you are accurate and correct. We reserve the right to modify or revoke this letter if: (1) there are any inaccuracies in the information submitted in support of your request for this letter, (2) the qualification testing was flawed, (3) in-service performance or other information reveals safety problems, (4) the system is significantly different from the version that was crash tested, or (5) any other information indicates that the letter was issued in error or otherwise does not reflect full and complete information about the crashworthiness of the system.

Standard Provisions

- To prevent misunderstanding by others, this letter of eligibility designated as FHWA control number B-278 shall not be reproduced except in full. This letter and the test documentation upon which it is based are public information. All such letters and documentation may be reviewed upon request.
- This letter shall not be construed as authorization or consent by the FHWA to use, manufacture, or sell any patented system for which the applicant is not the patent holder.
- If the subject device is a patented product it may be considered to be proprietary. If proprietary systems are specified by a highway agency for use on Federal-aid projects: (a) they must be supplied through competitive bidding with equally suitable unpatented items; (b) the highway agency must certify that they are essential for synchronization with the existing highway facilities or that no equally suitable alternative exists; or (c) they must be used for research or for a distinctive type of construction on relatively short sections of road for experimental purposes. Our regulations concerning proprietary products are contained in Title 23, Code of Federal Regulations, Section 635.411.

Sincerely,



Scott T. Johnson
Acting Director, Office of Safety
Technologies
Office of Safety

Enclosures

Request for Federal Aid Reimbursement Eligibility of Highway Safety Hardware

Submitter	Date of Request:	November 23, 2016	<input type="radio"/> New <input checked="" type="radio"/> Resubmission
	Name:	Maggie Ellis	
	Company:	Mondo Polymer Technologies, Inc.	
	Address:	P.O. Box 250 Reno, OH 45773	
	Country:	Unites States	
	To:	Michael S. Griffith, Director FHWA, Office of Safety Technologies	

I request the following devices be considered eligible for reimbursement under the Federal-aid highway program.

Device & Testing Criterion - Enter from right to left starting with Test Level

!-!-!

System Type	Submission Type	Device Name / Variant	Testing Criterion	Test Level
'B': Rigid/Semi-Rigid Barriers	<input checked="" type="radio"/> Physical Crash Testing <input type="radio"/> Engineering Analysis	Mondo Polymer 8" Composite Blockout with cut-outs (Model # GB14SH2) for Steel post Midwest Guardrail System (MGS)	AASHTO MASH	TL3

By submitting this request for review and evaluation by the Federal Highway Administration, I certify that the product(s) was (were) tested in conformity with the AASHTO Manual for Assessing Safety Hardware and that the evaluation results meet the appropriate evaluation criteria in the MASH.

Individual or Organization responsible for the product:

Contact Name:	Maggie Ellis	Same as Submitter <input checked="" type="checkbox"/>
Company Name:	Mondo Polymer Technologies, Inc.	Same as Submitter <input checked="" type="checkbox"/>
Address:	P.O. Box 250 Reno, OH 45773	Same as Submitter <input checked="" type="checkbox"/>
Country:	Unites States	Same as Submitter <input checked="" type="checkbox"/>
Enter below all disclosures of financial interests as required by the FHWA 'Federal-Aid Reimbursement Eligibility Process for Safety Hardware Devices' document.		
With respect to the Mondo Polymer Technologies 8" Composite Blockout (Model # GB14SH2), TTI Proving Ground does not hold any financial interests. Mondo Polymer Technologies contracted for the service of crash testing our product according to specifications for AASHTO Manual for Assessing Safety Hardware (MASH) Test 3-11, for which TTI Proving Ground was compensated for the cost of the crash test. No consulting relationship, research funding or other forms of research support, patents, copyrights, other intellectual property interests, licenses, contractual relationships, business ownership or investments interests are retained for the TTI Proving Ground.		

PRODUCT DESCRIPTION

- New Hardware or Significant Modification
 Modification to Existing Hardware

The Midwest Guardrail System (MGS) utilizes a 31-inch tall W-beam guardrail system with steel posts. The Mondo Polymer Technologies composite offset blocks with cut-outs (Model # GB14SH2) were installed on posts 9 through 24. Standard 12-gauge, galvanized W-beam sections (RWM04A) were installed with the top of the W-beam rail set at 31 inches above grade, and guardrail splices were located mid-span between every other post. The posts are PWE01 line posts fabricated from W6x8.5 structural shape and ASTM A36 steel, embedded 40 inches. The Mondo Polymer Composite Blockouts (GB14SH2) were attached to the steel posts using 5/8" diameter x 10" long button-head guardrail bolts and recessed nuts (FBB03).

The dimensions of the Mondo Polymer Composite Blockout (GB14SH2) are 14.19 inches long by 4 inches wide at the block/guardrail interface and remain constant for 6.98 inches before flaring out to 5.13 inches at the post/block interface. A .38 inch deep by 4.25 inch wide recess accommodates the post flange, making the effective block depth 7.63 inches. There are two bolt holes that are .74 inches at the guardrail/block interface and 1.06 inches at the post/block interface. There are two rectangular openings running on a parallel plain with the bolt holes that are 2.47 inches by 4.47 inches at the guardrail/block interface, and taper to 3.00 inches by 5.00 inches at the post/block interface. In addition, there are oval cut-outs on the sides of the block centered perpendicular to the rectangular openings. The center point of the upper ovals are 3.73 inches below the hanger end and 3.5 inches in from the guardrail/block interface. The center point of the lower oval is 3.46 inches above the bottom face and 3.5 inches in from the guardrail/block interface. These ovals are 5 inches by 3.75 inches.

The guardrail block (Model # GB14SH2) is manufactured from approximately 85% Thermoplastic Polyolefins and 15% fillers and/or trace plastics, and weighs approximately 5.95 lbs.

CRASH TESTING

By signature below, the Engineer affiliated with the testing laboratory, agrees in support of this submission that all of the critical and relevant crash tests for this device listed above were conducted to meet the MASH test criteria. The Engineer has determined that no other crash tests are necessary to determine the device meets the MASH criteria.

Engineer Name:	Roger Bligh	
Engineer Signature:	Bligh, Roger P	Digitally signed by Bligh, Roger P DN: postalCode=77843, o=TAMU-SIGN, street=Texas A&M University, st=TX, l=College Station, c=US, cn=Bligh, Roger P, email=rbligh@tamu.edu Date: 2017.02.01 15:33:55 -0600
Address:	3135 TAMU, College Station, Texas 77843-3135	Same as Submitter <input type="checkbox"/>
Country:	United States	Same as Submitter <input type="checkbox"/>

A brief description of each crash test and its result:

Required Test Number	Narrative Description	Evaluation Results
3-10 (1100C)	<p>The Midwest Guardrail System utilizing a 31 inch W-beam guardrail with 8 inch routed wood offset blocks or FHWA eligible alternative, with the splices located midspan between posts was successfully tested under MASH 3-10 impact conditions. This test was sponsored by Texas Department of Transportation, and conducted by Texas A&M Transportation Institute. Texas Department of Transportation received FHWA eligibility on Nov. 8, 2012 under reference # HSST/B-240. Additionally, the Midwest Guardrail System utilizing 31 inch W-beam guardrail with no blockout and the splices located midspan between posts was successfully tested under MASH 3-10 impact conditions. This test was conducted by Midwest Roadside Safety Facility (test no. MGSNB-2, report no. TRP-03-262-12). Midwest Roadside Safety Facility received FHWA eligibility on Sept. 6, 2013 under reference # HSST/B-243. Because the small car does not put as much structural demand on the blockouts or guardrail system, the pick-up truck test was the most critical test for evaluating the strength and function of the Mondo Polymer 8" Blockout with cut-outs (GB145H2). As indicated above, MASH test 3-10 has been successfully performed on the MGS with both 8" wood blockouts and without any blockouts. The success of these tests indicates that occupant severity is not critical for the small car test with the Mondo Polymer 8" Blockout with cut outs (GB145H2).</p>	Non-Critical, not conducted

Required Test Number	Narrative Description	Evaluation Results
3-11 (2270P)	The results of the test conducted on July 18, 2016 are found in TTI Test Report No. 690900-MON2 . The 31-inch high MGS guardrail installation with the 8-inch guardrail offset blocks (GB145H2), contained and redirected the 2270P vehicle. The vehicle did not penetrate, underide, or override the installation. Maximum dynamic deflection during the test was 50.8 inches. The blockouts separated from posts 16-19. However, these detached elements did not penetrate or show potential for penetrating the occupant compartment, or present hazard to others in the area. No occupant compartment deformation or intrusion occurred. The 2270P vehicle remained upright during and after the impact. Maximum roll and pitch angles were 26 degrees and 11 degrees, respectively. Occupant risk factors were within the preferred limits specified in MASH.	PASS
3-20 (1100C)	Optional Test not performed. This offset block component submission is for a stand alone LON barrier system only, not for transition to any stiffer or more rigid barrier systems. Therefore, test 3-20 is not relevant.	Non-Relevant Test, not conducted
3-21 (2270P)	Test not performed. This offset block component submission is for a stand alone LON barrier system only, not for transition to any stiffer or more rigid barrier systems. Therefore, test 3-21 is not relevant.	Non-Relevant Test, not conducted

Full Scale Crash Testing was done in compliance with MASH by the following accredited crash test laboratory (cite the laboratory's accreditation status as noted in the crash test reports.):

Laboratory Name:	Texas AM Transportation Institute	
Laboratory Signature:	Darrell L. Kuhn	Darrell L. Kuhn 2017.02.02 17:09:19 -06'00'
Address:	3135 TAMU, College Station, Texas 77843-3135	Same as Submitter <input type="checkbox"/>
Country:	United States	Same as Submitter <input type="checkbox"/>
Accreditation Certificate Number and Dates of current Accreditation period :	A2LA Certificate Number 2821.01 valid until April 30, 2017	

Submitter Signature*: **Maggie Ellis**
Digitally signed by Maggie Ellis
DN: cn=Maggie Ellis
Date: 2017.02.03 08:00:11 -05'00'

Submit Form

ATTACHMENTS

Attach to this form:

- 1) Additional disclosures of related financial interest as indicated above.
- 2) A copy of the full test report, video, and a Test Data Summary Sheet for each test conducted in support of this request.
- 3) A drawing or drawings of the device(s) that conform to the Task Force-13 Drawing Specifications [Hardware Guide Drawing Standards]. For proprietary products, a single isometric line drawing is usually acceptable to illustrate the product, with detailed specifications, intended use, and contact information provided on the reverse. Additional drawings (not in TF-13 format) showing details that are relevant to understanding the dimensions and performance of the device should also be submitted to facilitate our review.

FHWA Official Business Only:

Eligibility Letter		
Number	Date	Key Words

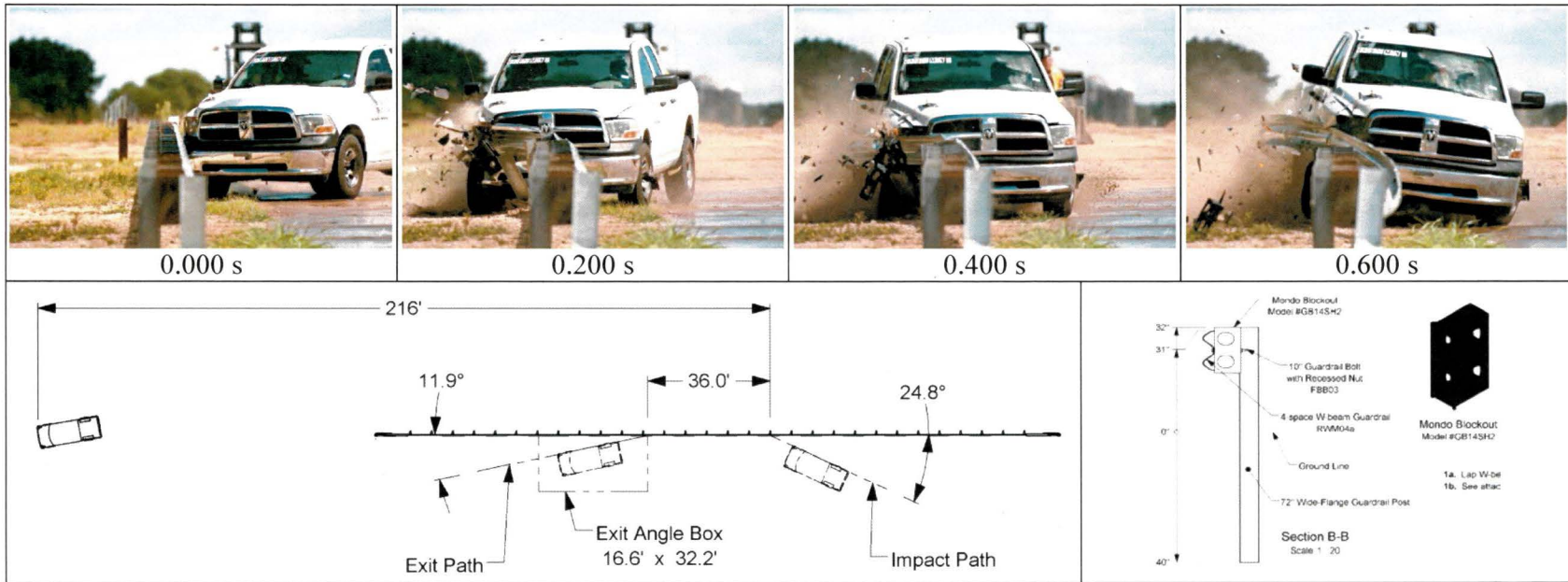

General Information

Test Agency..... Texas A&M Transportation Institute (TTI)
 Test Standard Test No. MASH Test 3-11
 TTI Test No. 690900-MON2
 Test Date 2016-07-18

Test Article

Type Guardrail
 Name..... MGS with 8-inch Mondo Polymer Technology blockouts
 Installation Length..... 201 ft 7 inches
 Material or Key Elements 31-inch tall MGS W-beam guardrail on structural steel posts with redesigned 8-inch Mondo Polymer blockouts

Soil Type and Condition AASHTO M147-65(2004), grading B Soil (crushed limestone), dry

Test Vehicle

Type/Designation 2270P
 Make and Model 2012 Dodge RAM 1500 Pickup
 Curb..... 5006 lb
 Test Inertial..... 5042 lb
 Dummy No dummy
 Gross Static 5042 lb

Impact Conditions

Speed66.3 mi/h
 Angle24.8 degrees
 Location/Orientation

Impact Severity.....130 kip-ft

Exit Conditions

Speed42.2 mi/h
 Angle11.9 degrees

Occupant Risk Values

Longitudinal OIV14.1 ft/s
 Lateral OIV.....16.7 ft/s
 Longitudinal Ridedown5.1 g
 Lateral Ridedown6.9 g
 THIV21 ft/s (23.0 km/h)
 PHD7.5 g
 ASI.....0.63

Max. 0.050-s Average

Longitudinal-4.3 g
 Lateral.....-5.0 g
 Vertical.....2.1 g

Post-Impact Trajectory

Stopping Distance.....216 ft downstream
 1 ft toward traffic

Vehicle Stability

Maximum Yaw Angle29 degrees
 Maximum Pitch Angle11 degrees
 Maximum Roll Angle26 degrees
 Vehicle SnaggingNo
 Vehicle PocketingNo

Test Article Deflections

Dynamic.....50.8 inches
 Permanent30.5 inches
 Working Width.....57.3 inches

Vehicle Damage

VDS01RFQ3
 CDC01FREW3
 Max. Exterior Deformation.....11.0 inches
 OCDI.....RF0000000
 Max. Occupant Compartment DeformationNone

Figure 5.6. Summary of Results for MASH Test 3-11 on MGS Guardrail Installation with New 8-inch Mondo Polymer Technology Guardrail Offset Blocks.

2

1



B

B

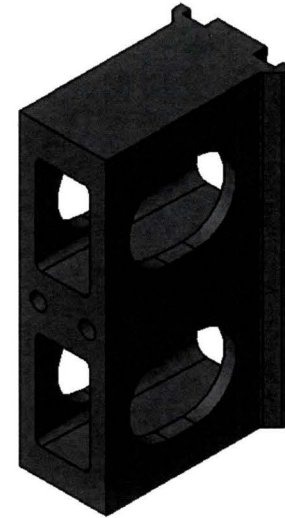
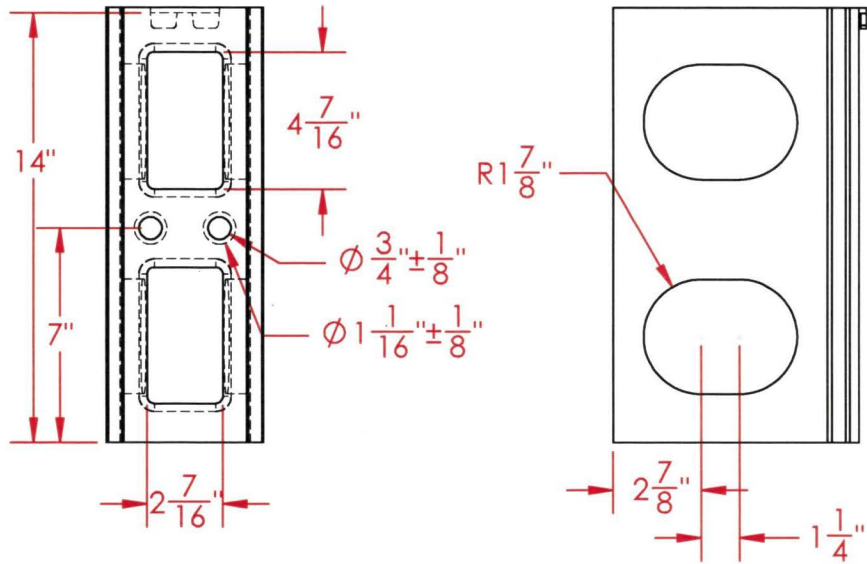

A

A

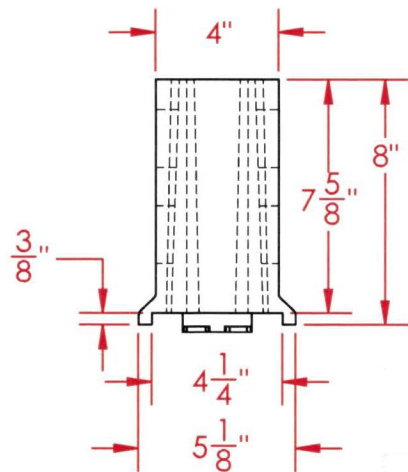

PROPRIETARY AND CONFIDENTIAL
THE INFORMATION CONTAINED IN THIS DRAWING IS THE SOLE PROPERTY OF MONDO POLYMER TECHNOLOGIES. ANY REPRODUCTION IN PART OR AS A WHOLE WITHOUT THE WRITTEN PERMISSION OF MONDO POLYMER TECHNOLOGIES IS PROHIBITED.

UNLESS OTHERWISE SPECIFIED:
DIMENSIONS ARE IN INCHES
TOLERANCES:
BOLT HOLES +/- 1/8"
ALL OTHERS +/- 1/4"
MATERIAL

DRAWN	NAME	DATE
REVISION	RICK H	4/28/16
COMMENTS:		

MONDO MODEL NO.		
GB14SH2		
SIZE	DWG. NO.	REV
A		
SCALE: 1:6	SHEET 1 OF 1	

2

1

**APPENDIX A. DETAILS OF THE MGS GUARDRAIL WITH
8-INCH MONDO POLYMER TECHNOLOGIES
GUARDRAIL OFFSET BLOCKS**

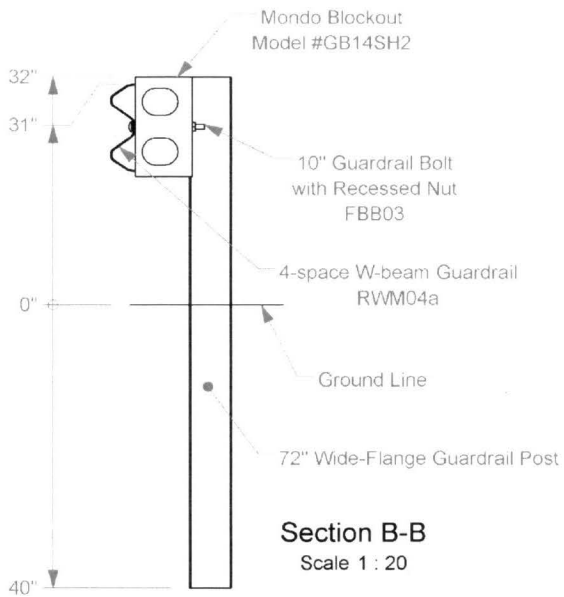
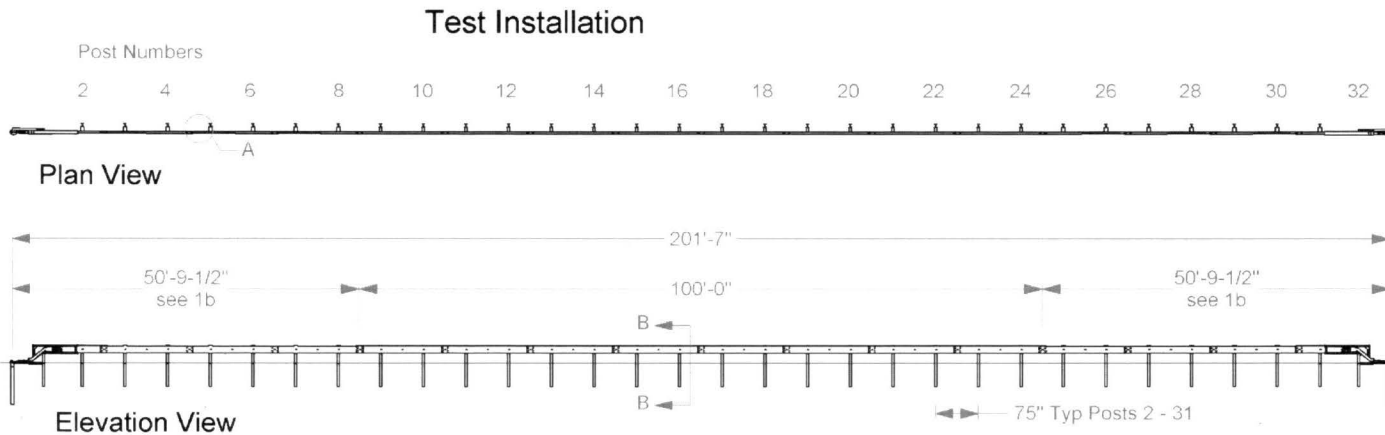

Mondo Blockout
Model #GB14SH2

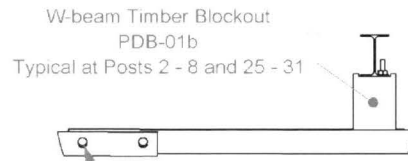

Detail A
Scale 1 : 20

- 1a. Lap W-beam as appropriate for impact direction, not necessarily as shown.
- 1b. See attached drawings for Terminal and Part details.



Roadside Safety and Physical Security Division
Proving Ground -

Project 690900-MON-2 Mondo GB14SH2 Blockouts
Drawn By GES Scale 1:250 Sheet 1 of 1 Test Installation

Approved by
Roger Bligh

Roger Bligh

Date:
2016-06-08

T:\1-ProjectFiles\690900-Compliance\MON - Mondo Polymer Technologies - Bligh\MON2\Drafting\690900-MON-2 Drawing