



Texas A&M Transportation Institute
3135 TAMU
College Station, TX 77843-3135

Phone: 979-317-2000
Fax: 979-845-6107
<http://tti.tamu.edu/crashtesting>

**Professional Opinion
Butterfly Reflectors**

**Roadside Safety Pooled Fund
Engineering Support/Professional Opinion Project**

Prepared by:

Maysam Kiani, Ph.D.

December 2019

Professional Opinion: Butterfly Reflectors

The Alaska Department of Transportation & Public Facilities (ADOT&PF) has asked TTI researchers to investigate the crashworthiness of Butterfly Reflectors (Figure 1) placed in the web of guardrails. According to Low-Cost Treatments for Horizontal Curve Safety published in 2016 by Federal Highway Administration (FHWA), metal Butterfly Reflectors should not be used where the bolt holds the guardrail to the post considering that it may act as a washer and prevent the proper performance of the rail in a crash [1]. TTI researchers believe the negative effect on the performance is not limited only to “metal” reflectors. If a Butterfly Reflector made of any material is placed at a post bolt, it may influence the pullout force of the post bolt, which can negatively affect the impact performance of the system. Thus, TTI researchers believe that Butterfly Reflectors can be placed anywhere other than under a post bolt. As an alternative, flexible post-mounted delineators, represented in Figure 2, can be used at post locations.

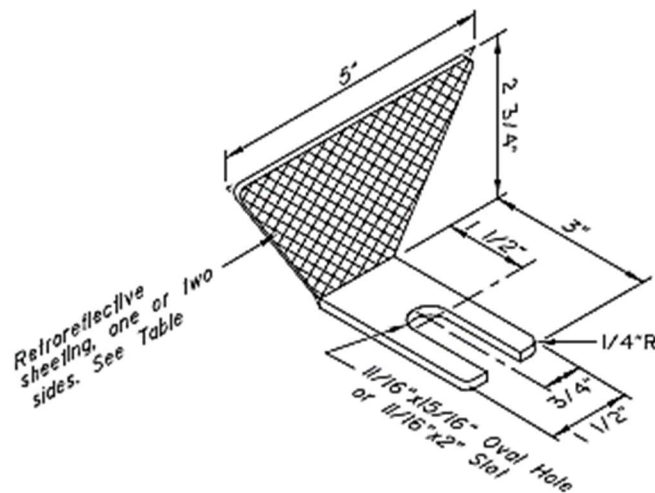

Figure 1. Butterfly Reflector [2]

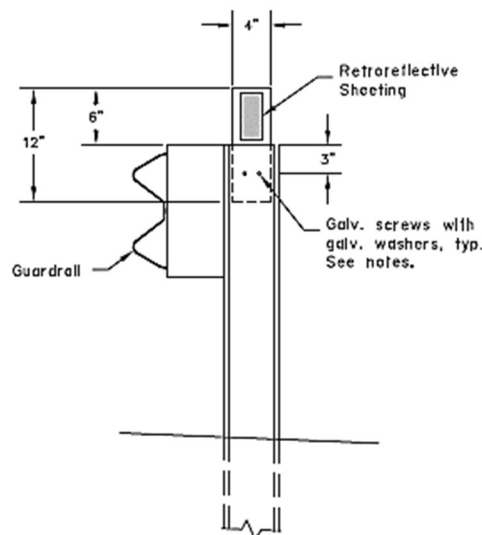

Figure 2. Flexible post-mounted delineator [3]

References

1. FHWA, “Low-Cost Treatments for Horizontal Curve Safety”, 2016, https://safety.fhwa.dot.gov/roadway_dept/horcurves/fhwasa15084/
2. ADOT&PF Standard Drawings, Standard Guardrail Hardware (G-00.04), p4, <http://www.dot.state.ak.us/stwddes/dcsprecon/assets/pdf/stdwgs/eng/g0004p4.pdf>
3. ADOT&PF Standard Drawings, Standard Guardrail Hardware (G-00.04), p5, <http://www.dot.state.ak.us/stwddes/dcsprecon/assets/pdf/stdwgs/eng/g0004p5.pdf>